



# ALUMFRAME



Alumframe è una linea di profili in legno-alluminio progettati per portare uno stile contemporaneo e di design all'interno della tradizione degli infissi e dei serramenti in legno.

The logo for ALUMFRAME features the word "ALUMFRAME" in a bold, sans-serif font. The letters "ALUM" are colored red, while "FRAME" is black. A thick black square frame is positioned behind the text, with its right side cut off by the word "ALUM".

**ALUMFRAME**

Alumfast è un innovativo sistema di vendita in kit dei profili in legno-alluminio Alumframe, pensato per ridurre i costi e guadagnare tempo, senza rinunciare alla qualità.

**VENDITA IN KIT**

- Facile e rapido
- Ogni finestra in una confezione pronta per l'assemblaggio
- Istruzioni di montaggio sintetiche e di facile lettura

**NIENTE PIÙ BANCALI**

- Zero problemi di gestione dell'imballo
- Nessuno stoccaggio di materiale: accessori premontati sui telaietti
- Sostituzione immediata in caso di inconvenienti

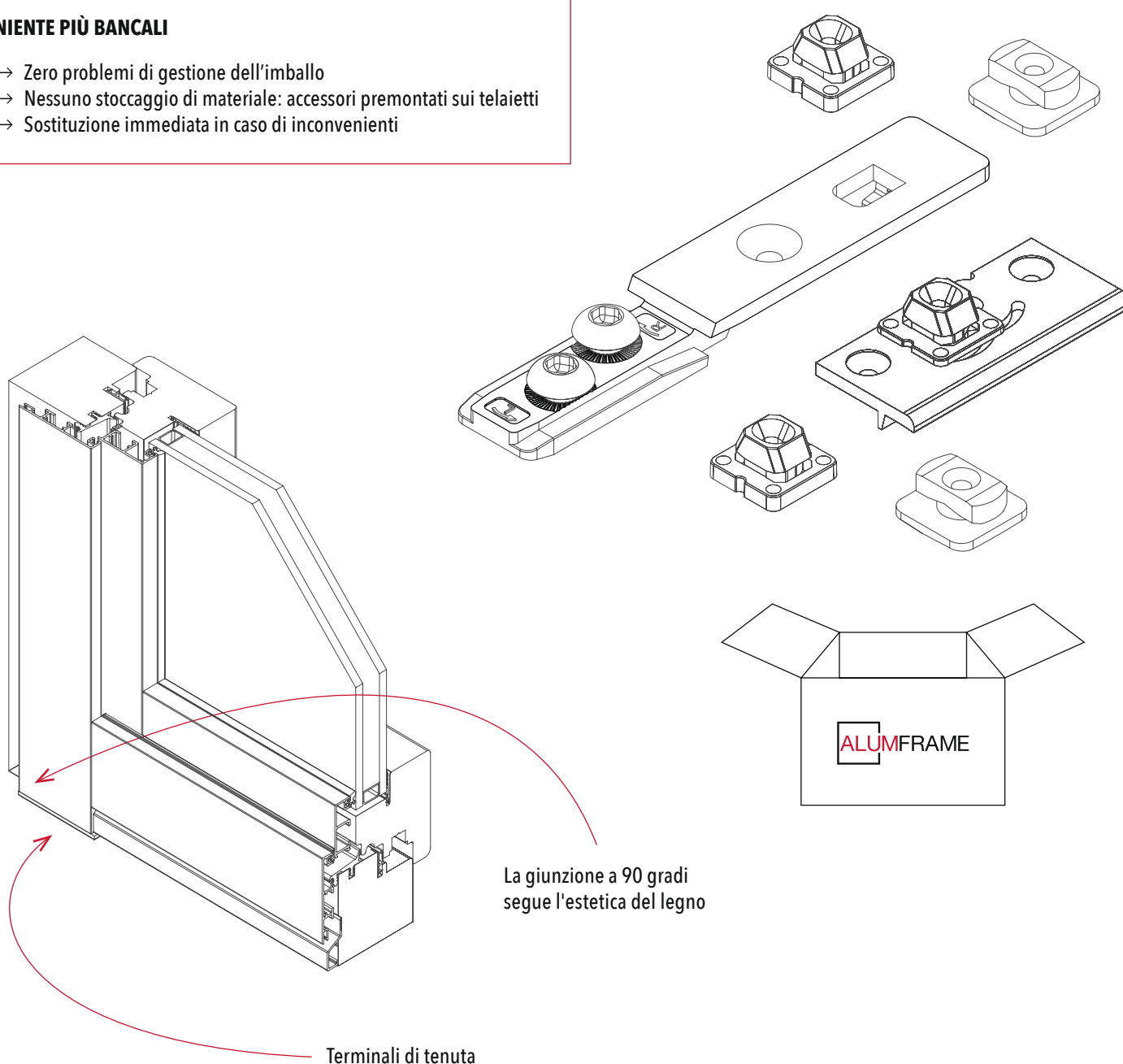

Premontato sui montanti telaio, il terminale ha come funzione principale quella di chiudere l'intercapedine tra alluminio e legno. Il terminale favorisce così l'evacuazione dell'acqua ed evita le infiltrazioni nel muro. Il risultato è garantito da test effettuati in laboratorio.

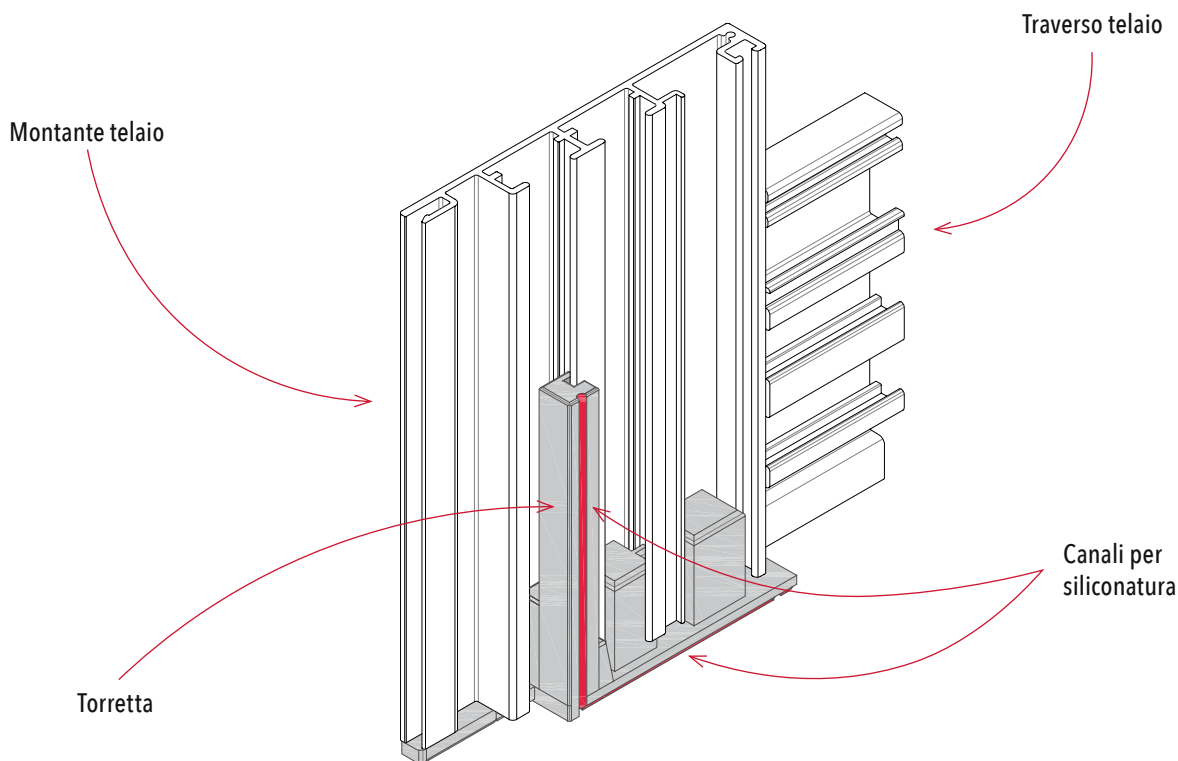

**TERMINALE PER IL PROFILO ANTA**

Premontato sui montanti anta, il terminale ha come funzione principale la finitura del profilo, nonché di sicurezza contro il taglio su alluminio vivo.

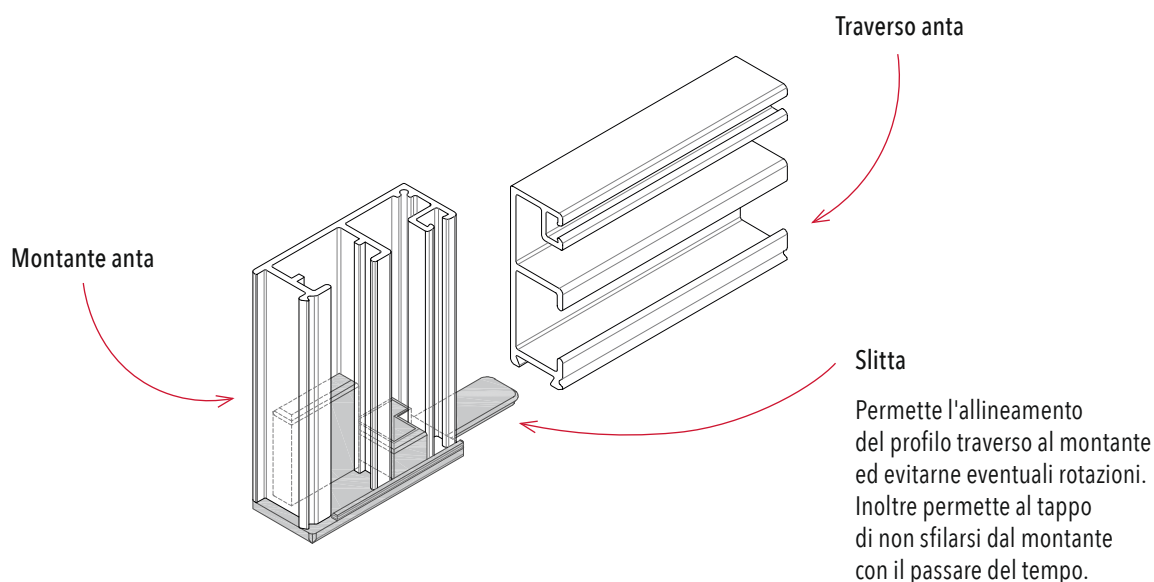

I terminali per il profilo telaio e per il profilo anta sono disponibili nei colori bianco e nero.

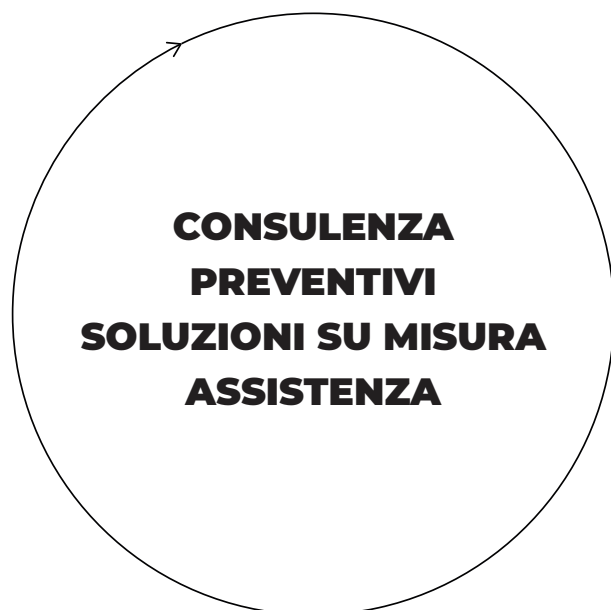

#### UFFICIO TECNICO

Accompagnamo i nostri clienti nella scelta delle soluzioni migliori per risolvere problematiche molto diverse tra loro. Mettiamo a disposizione le nostre competenze tecniche nelle fasi di sviluppo, progettazione e post-vendita dei nostri prodotti e progetti.

#### SPEDIZIONI SICURE

Nessuno ha tempo da perdere! Spedizioni sicure e tracciate, efficienza nell'organizzazione e nella gestione degli ordini, imballi resistenti a "prova d'urto": sono questi gli ingredienti che ci hanno permesso di spedire ai nostri clienti in Europa e nel mondo.

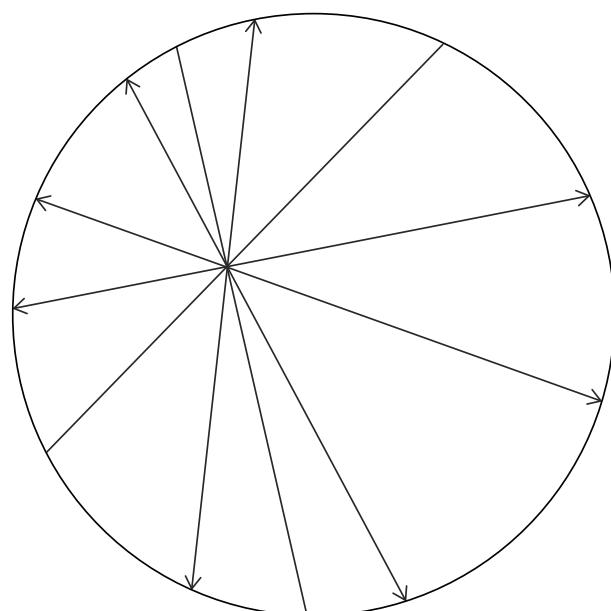

#### RETE COMMERCIALE

Ci affidiamo a una squadra di agenti esperti sia in campo tecnico che commerciale, dislocata su territorio nazionale. Un network di persone preparate per stabilire contatti diretti tra noi e i nostri clienti. Contattaci per conoscere l'agente più vicino a te.

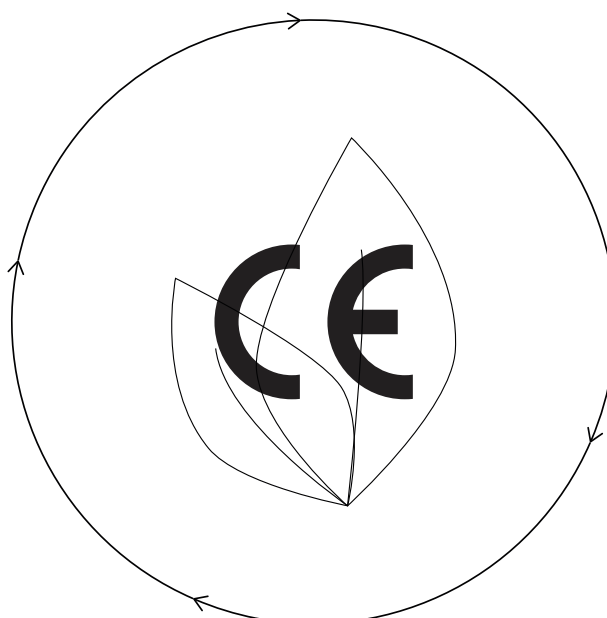

#### CERTIFICAZIONI

Innovazione e sicurezza sono sinonimi di consapevolezza e responsabilità. Per questo motivo vogliamo che le tue finestre durino nel tempo e proponiamo prodotti affidabili e testati, conformi alla marcatura CE in linea con le direttive europee in materia.



<b>8</b>	<b>SISTEMI LEGNO</b>	
<b>12</b>	<b>ALUMFAST</b>	
<b>14</b>	<b>ALUMFAST SISTEMA 21</b> STANDARD	
<b>26</b>	<b>ALUMFAST SISTEMA 21</b> SLIDE	
<b>32</b>	<b>ALUMFAST SISTEMA 16</b> STANDARD	
<b>38</b>	<b>ALUMFAST SISTEMA 16</b> SLIDE	
<b>44</b>	<b>ALUMFAST SISTEMA 21 E SISTEMA 16</b> ABBINAMENTI	
<b>56</b>	<b>ALUMFAST SISTEMA 21 E SISTEMA 16</b> FISSI, TRAVERSI, INGLESINE	
<b>60</b>	<b>ALUMFAST SISTEMA 16 ECO</b> STANDARD	
<b>72</b>	<b>ALUMFAST SISTEMA 16 ECO</b> SLIDE	
<b>78</b>	<b>ALUMFAST SISTEMA 16 ECO</b> ABBINAMENTI	
<b>86</b>	<b>ALUMFAST SISTEMA 16 ECO</b> FISSI	<b>ALUMFAST SISTEMI 21 / 16 / 16 ECO</b> 14 - 89
<b>90</b>	<b>ALUMFAST EASY</b> STANDARD	
<b>100</b>	<b>ALUMFAST EASY</b> SLIDE	
<b>106</b>	<b>ALUMFAST EASY</b> ABBINAMENTI	
<b>110</b>	<b>ALUMFAST EASY</b> SLIM	
<b>120</b>	<b>ALUMFAST EASY</b> HP80	<b>ALUMFAST EASY</b> 90 - 125
<b>126</b>	<b>ALUMFAST GRACE</b> STANDARD	
<b>134</b>	<b>ALUMFAST GRACE</b> HP80	<b>ALUMFAST GRACE</b> 126 - 139
<b>140</b>	<b>ALUMFAST CANVAS</b> STANDARD	
<b>148</b>	<b>ALUMFAST CANVAS</b> ANTA TELAIO UGUALE SPESSORE	
<b>154</b>	<b>ALUMFAST CANVAS</b> ORIZON STANDARD	
<b>162</b>	<b>ALUMFAST CANVAS</b> ORIZON ANTA TELAIO UGUALE SPESSORE	<b>ALUMFAST CANVAS</b> 140 - 169
<b>170</b>	<b>ALUMFAST ORIZON</b> STANDARD	
<b>180</b>	<b>ALUMFAST ORIZON</b> SLIM	
<b>190</b>	<b>ALUMFAST ORIZON</b> SLIM VETRO A FILO	
<b>196</b>	<b>ALUMFAST ORIZON</b> HP80	
<b>202</b>	<b>ALUMFAST ORIZON</b> SLIM HP80	
<b>208</b>	<b>ALUMFAST ORIZON</b> SLIM HP80 VETRO A FILO	
<b>214</b>	<b>ALUMFAST ORIZON</b> SISTEMA 21 / SISTEMA 16	
<b>228</b>	<b>ALUMFAST ORIZON</b> SISTEMA 16 ECO	<b>ALUMFAST ORIZON</b> 170 - 233
<b>234</b>	<b>BRIDGE EASY</b> SLIM	
<b>242</b>	<b>BRIDGE EASY</b> SLIM HP80	
<b>248</b>	<b>BRIDGE ALUMFAST</b> STANDARD	
<b>260</b>	<b>BRIDGE GRACE</b> STANDARD	
<b>268</b>	<b>BRIDGE GRACE</b> HP80	<b>BRIDGE</b> 234 - 275



<b>276</b>	<b>GHOST</b>	<b>GHOST</b> 276 - 283
<b>284</b>	<b>LUCE QUADRA</b>	
<b>292</b>	<b>LUCE ALUMFAST</b>	
<b>300</b>	<b>LUCE LEGNO</b>	<b>LUCE</b> 284 - 303
<b>304</b>	<b>BILICO</b>	
<b>310</b>	<b>PORTE AD APERTURA ESTERNA</b>	
<b>316</b>	<b>ALZANTI SCORREVOLI</b>	
<b>319</b>	<b>ALZANTI SCORREVOLI</b> AGB STANDARD	
<b>325</b>	<b>ALZANTI SCORREVOLI</b> AGB DOPPIA ANTA SCORREVOLE	
<b>329</b>	<b>ALZANTI SCORREVOLI</b> AGB MAGO	
<b>335</b>	<b>ALZANTI SCORREVOLI</b> AGB IMAGO RIDOTTO	
<b>341</b>	<b>ALZANTI SCORREVOLI</b> MAICO STANDARD	
<b>347</b>	<b>ALZANTI SCORREVOLI</b> MAICO DOPPIA ANTA SCORREVOLE	
<b>351</b>	<b>ALZANTI SCORREVOLI</b> MAICO LUCE	
<b>357</b>	<b>ALZANTI SCORREVOLI</b> MAICO INFINITY VIEW	
<b>363</b>	<b>ALZANTI SCORREVOLI</b> GU STANDARD	
<b>369</b>	<b>ALZANTI SCORREVOLI</b> GU DOPPIA ANTA SCORREVOLE	
<b>373</b>	<b>ALZANTI SCORREVOLI</b> GU GRAN LUCE	<b>ALZANTI SCORREVOLI</b> 316 - 377
<b>378</b>	<b>COVERFAST</b> LINEA PORTONI	
<b>384</b>	<b>COVERFAST</b> SISTEMA 21 / SISTEMA 16	
<b>388</b>	<b>COVERFAST</b> SISTEMA 16 ECO	
<b>392</b>	<b>COVERFAST</b> EASY	<b>COVERFAST</b> 378 - 395
<b>396</b>	<b>RIEPILOGO</b> PROFILI	
<b>411</b>	<b>RIEPILOGO</b> ACCESSORI	
<b>414</b>	<b>RIEPILOGO</b> FINITURE	

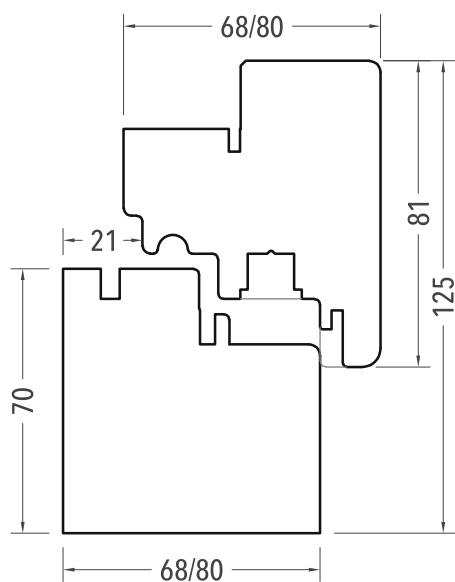

**SISTEMA 21**  
per Alumfast, serramenti tipo Euronorm

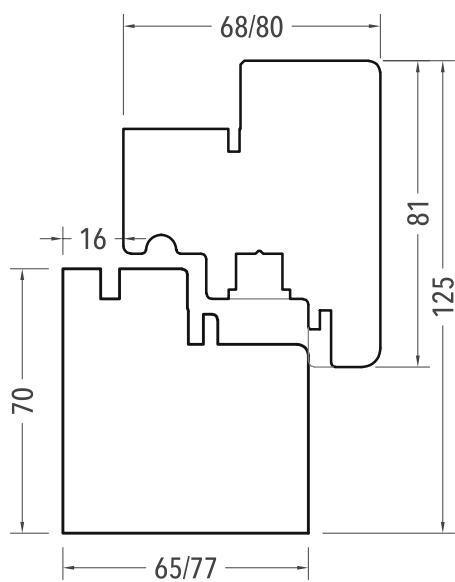

**SISTEMA 16**  
per Alumfast, serramenti tipo Freumex

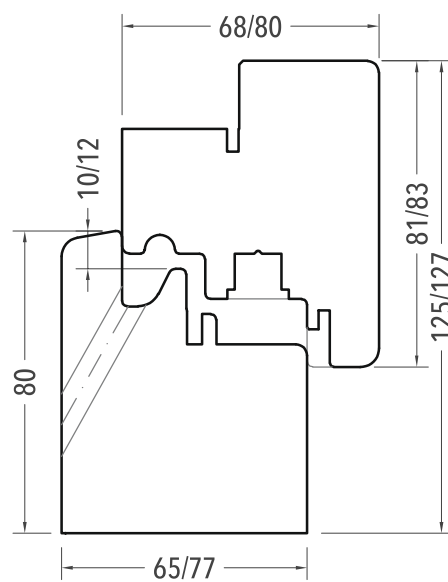

**SISTEMA 16 ECO**  
per Alumfast, serramenti tipo Freumex (legno)

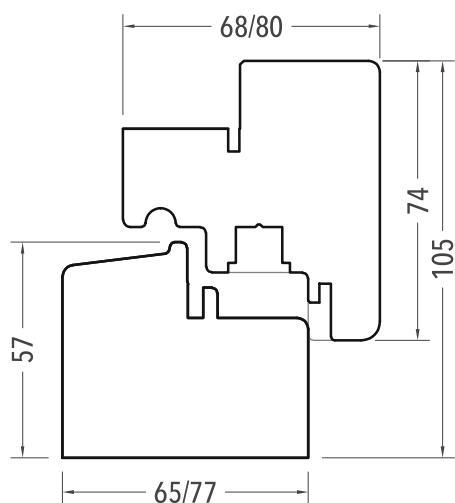

**SISTEMA EASY**  
per Alumfast

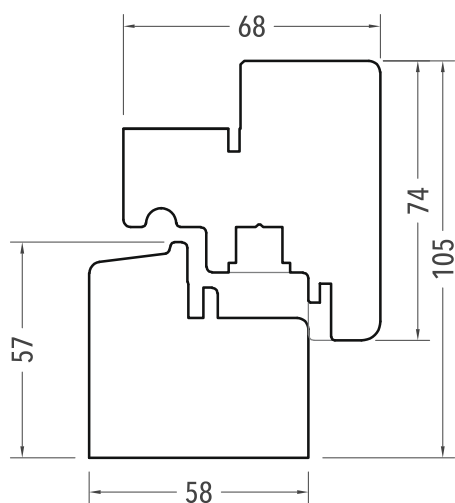

**SISTEMA EASY**  
per Alumfast Slim

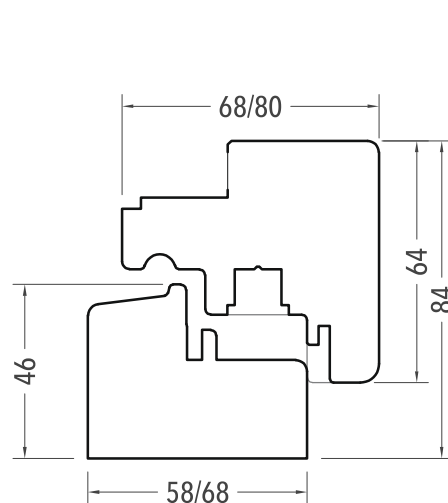

**SISTEMA EASY**  
per Alumfast Grace

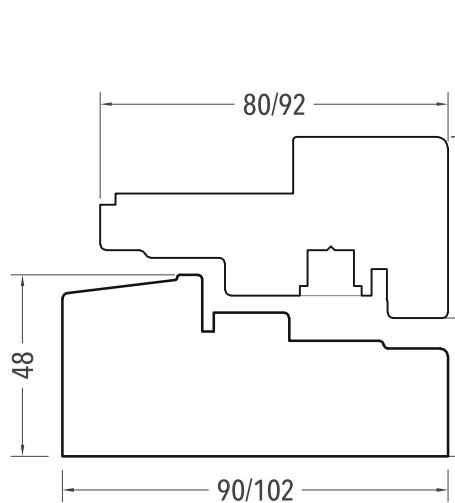

**SISTEMA CANVAS**

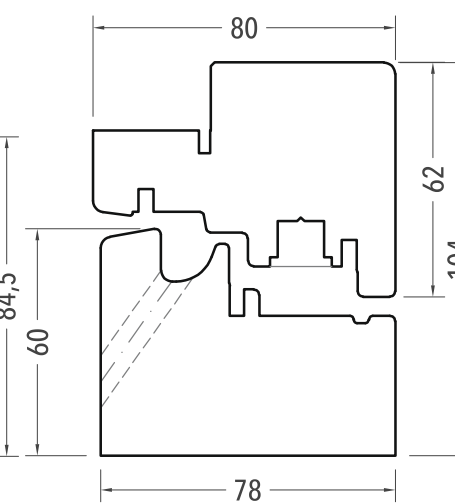

**SISTEMA GHOST**  
per Alumfast Slim

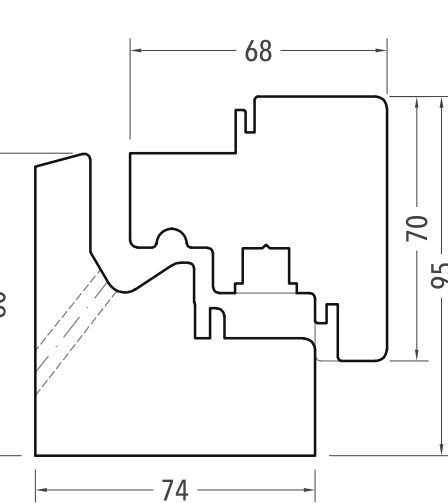

**SISTEMA LUCE**  
per linee Quadra e Plus

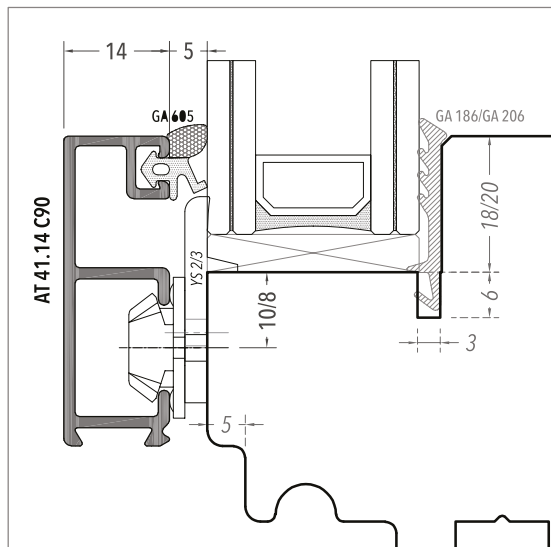

Battuta interna vetro con GA 186 / GA 206

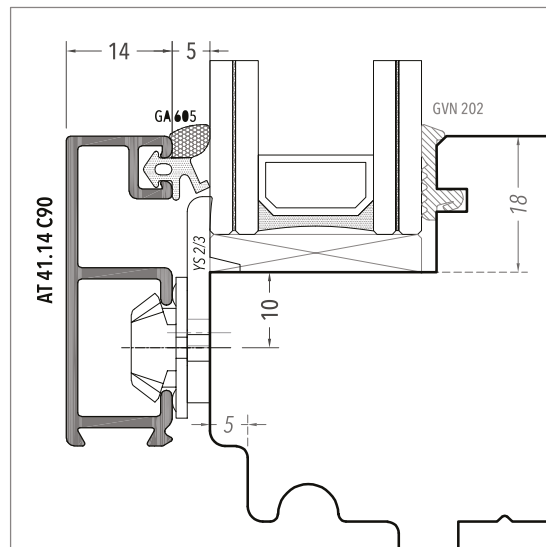

Battuta interna vetro con GVN 202

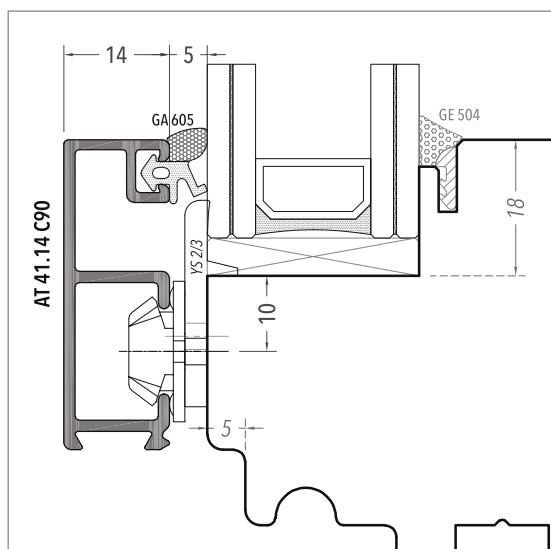

Battuta interna vetro con GE 504

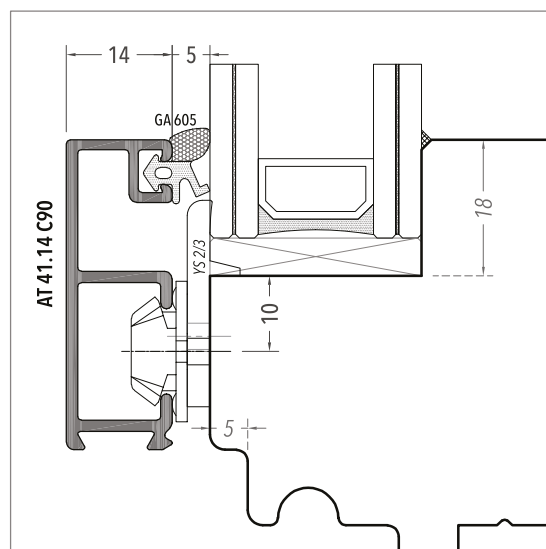

Battuta interna vetro senza guarnizione

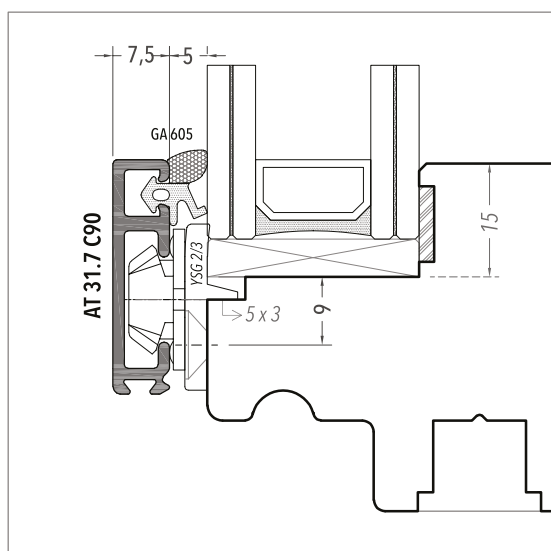

Battuta interna incollaggio strutturale con colla

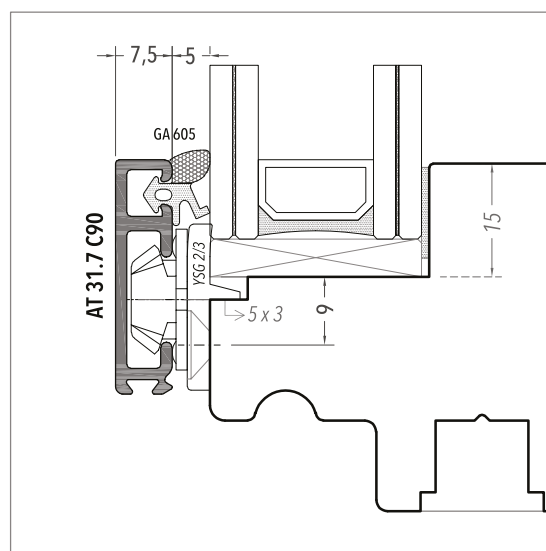

Battuta interna incollaggio strutturale con biadesivo

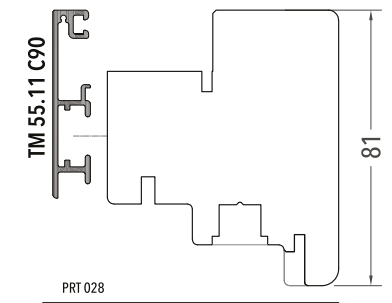
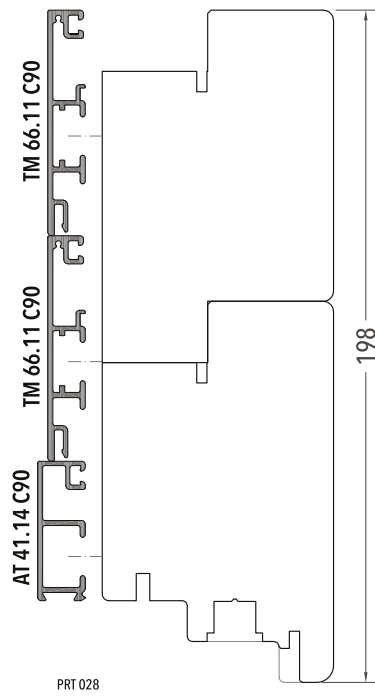
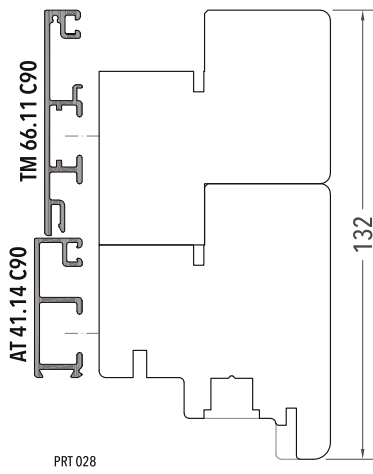
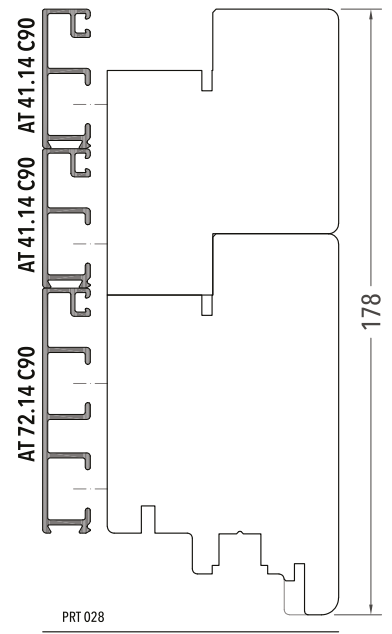
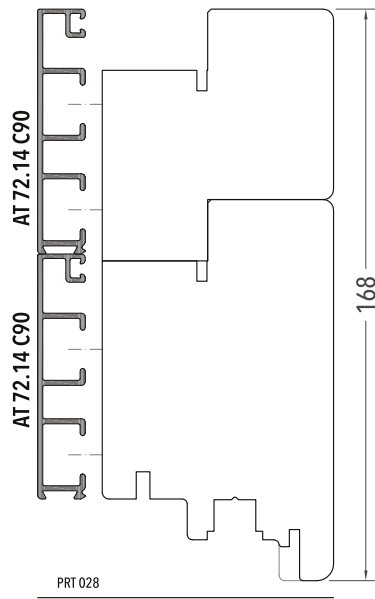
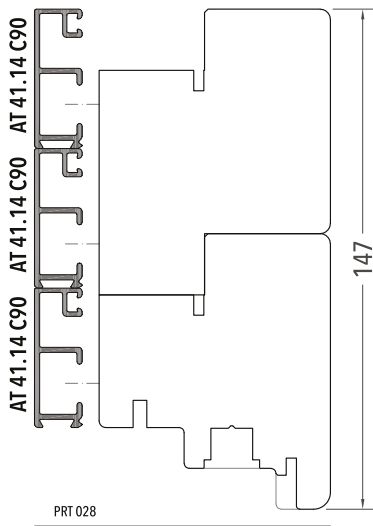
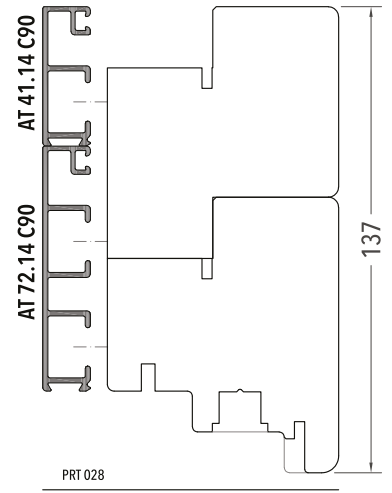
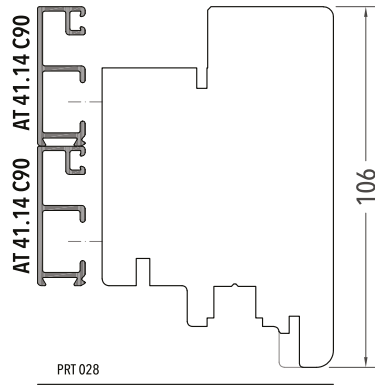
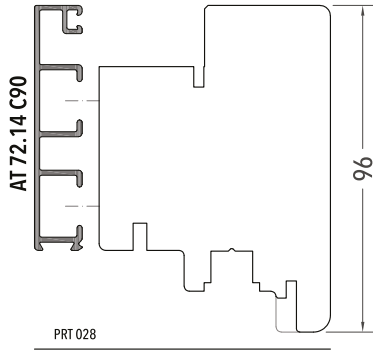

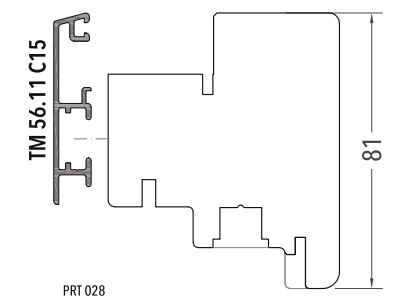
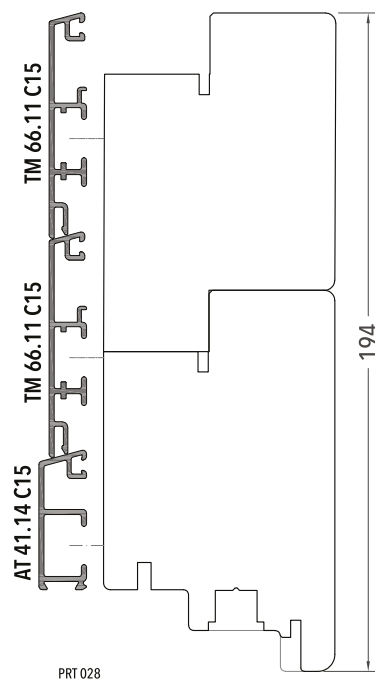
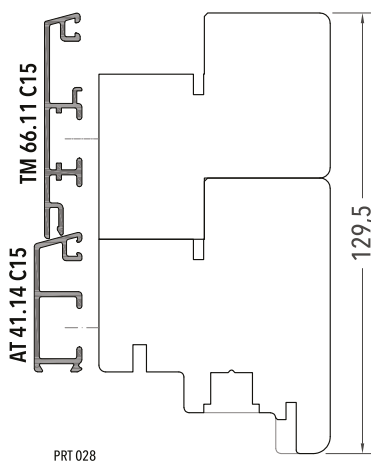
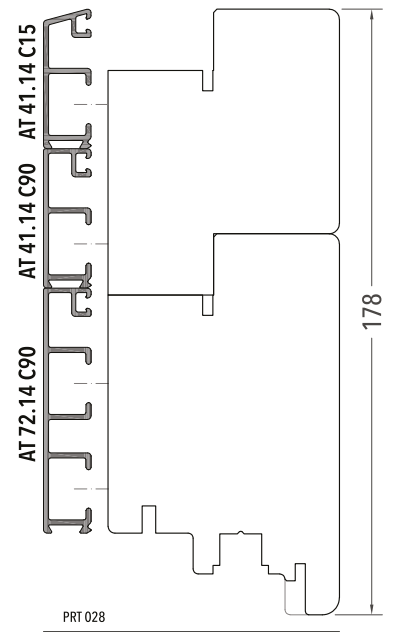
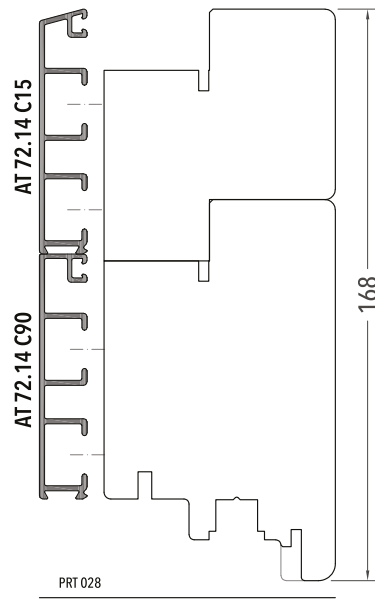
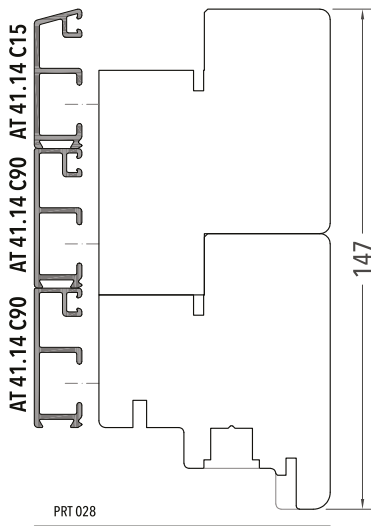
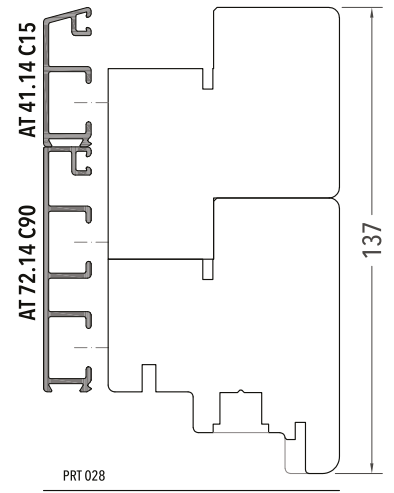
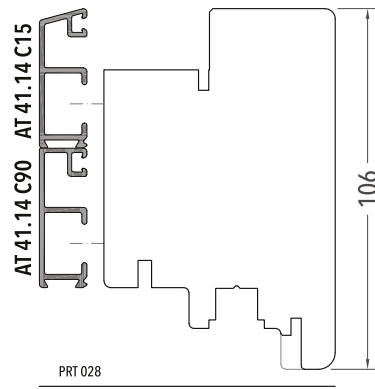
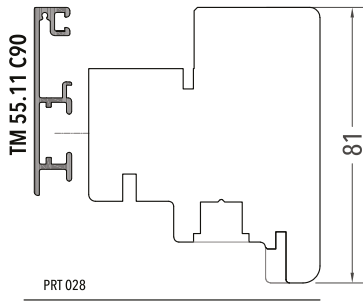

## **ALUMFAST: SEMPLICE E LOGICO**

Adatto a tutte le tipologie di serramento in legno, Alumfast è il sistema legno-alluminio con profilo a 90 gradi e sistema di montaggio brevettato di Alumframe.

Progettato per un'applicazione rapida ed efficace, Alumfast utilizza clip e accessori innovativi che riducono sensibilmente i tempi di montaggio dell'alluminio al legno. Alumfast si contraddistingue per un sistema di vendita innovativo e brevettato. Semplice e logico: ogni finestra, consegnata in kit, è imballata in confezioni separate con istruzioni di montaggio sintetiche e di facile lettura. In risposta alle esigenze di mercato, Alumfast garantisce un'agevole gestione degli imballi, tempi di consegna sensibilmente ridotti e sostituzione immediata in caso di danni.

## **ALUMFAST EASY**

Il telaio della versione Easy ha una geometria che garantisce perfetta tenuta all'acqua senza guarnizioni visibili che ne compromettono l'aspetto estetico. Alumfast Easy riduce maggiormente i costi di produzione e offre prestazioni termiche migliori grazie a un nodo ridotto. Con la linea Easy Slim, si propone un design sempre più minimale, con profili in alluminio da soli 8mm e prestazioni testate in laboratorio e in linea con quelle dei sistemi legno-alluminio tradizionali.

## **ALUMFAST GRACE**

Alumfast Grace amplia il più possibile la superficie vetrata dei serramenti per migliorarne le prestazioni e per creare una finestra minimalista con nodi ridottissimi, a partire da serramenti in legno standard.

## **ALUMFAST CANVAS**

Dallo studio e dalla ricerca di sistemi minimali e ad alte prestazioni, nasce la linea Canvas che permette di raggiungere un nodo finestre da 82mm.

## **ALUMFAST ORIZON**

Alumfast Orizon rivoluziona il sistema complanare introducendo per la prima volta una giunzione a 90 gradi, profili anta di spessori diversi e la fornitura in kit, come da tradizione Alumframe.

## **BRIDGE**

Il sistema Bridge nasce con l'intento di combinare una finestra economica con un design ultramoderno. Il profilo, dotato necessariamente di un solo aggancio per clip, ha una geometria molto allungata per poter ricoprire l'anta ed è progettato a matrice chiusa. Si garantisce così una minore deformabilità e un ulteriore fissaggio tramite vite di centraggio agli angoli del telaio in alluminio.

## **GHOST**

Ghost è la finestra complanare della famiglia Alumframe. Linee geometriche, unione ideale tra eleganza e innovazione: è la perfetta soluzione per edifici contemporanei che richiedono serramenti dalle forme squadrate, piane ed essenziali. Con Ghost è possibile adottare soluzioni di posa a filo muro, sia all'interno che all'esterno dell'edificio. Una finestra complanare al massimo delle sue possibilità tecniche, performanti ed estetiche.

## **LUCE**

Luce è la soluzione legno-alluminio ideale per uno stile minimalista e lineare. Il telaio scompare nel muro e garantisce una luminosità degli ambienti superiore al 25% rispetto ai sistemi legno-alluminio tradizionali. Il nodo è di dimensioni estremamente ridotte (95mm), pertanto la superficie vetrata è maggiore con ottime prestazioni termiche. Fornibile in kit e in telaietti già assemblati, le linee sottili del Luce combinano riduzione dei costi e design.

Tutti i profili di alluminio Alumfast sono realizzati in lega AW 6060 con spessore 1.5 mm, caratteristica che li rende meno soggetti a deformazione in fase di estrusione. I sistemi Alumfast sono coperti da certificazione a cascading per marcatura CE.

# Alumfast

---

SEZIONI



Spessore telaio 68  
Spessore anta 68  
Per serramenti Euronorm



# Alumfast Sistema 21

---

STANDARD

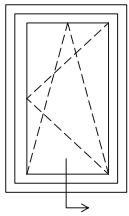

**FINESTRA**

SEZIONE VERTICALE  
 NODO INFERIORE  
 SCALA 1:1

Variante traverso  
 inferiore con profilo  
 Slide inclinato a 15°

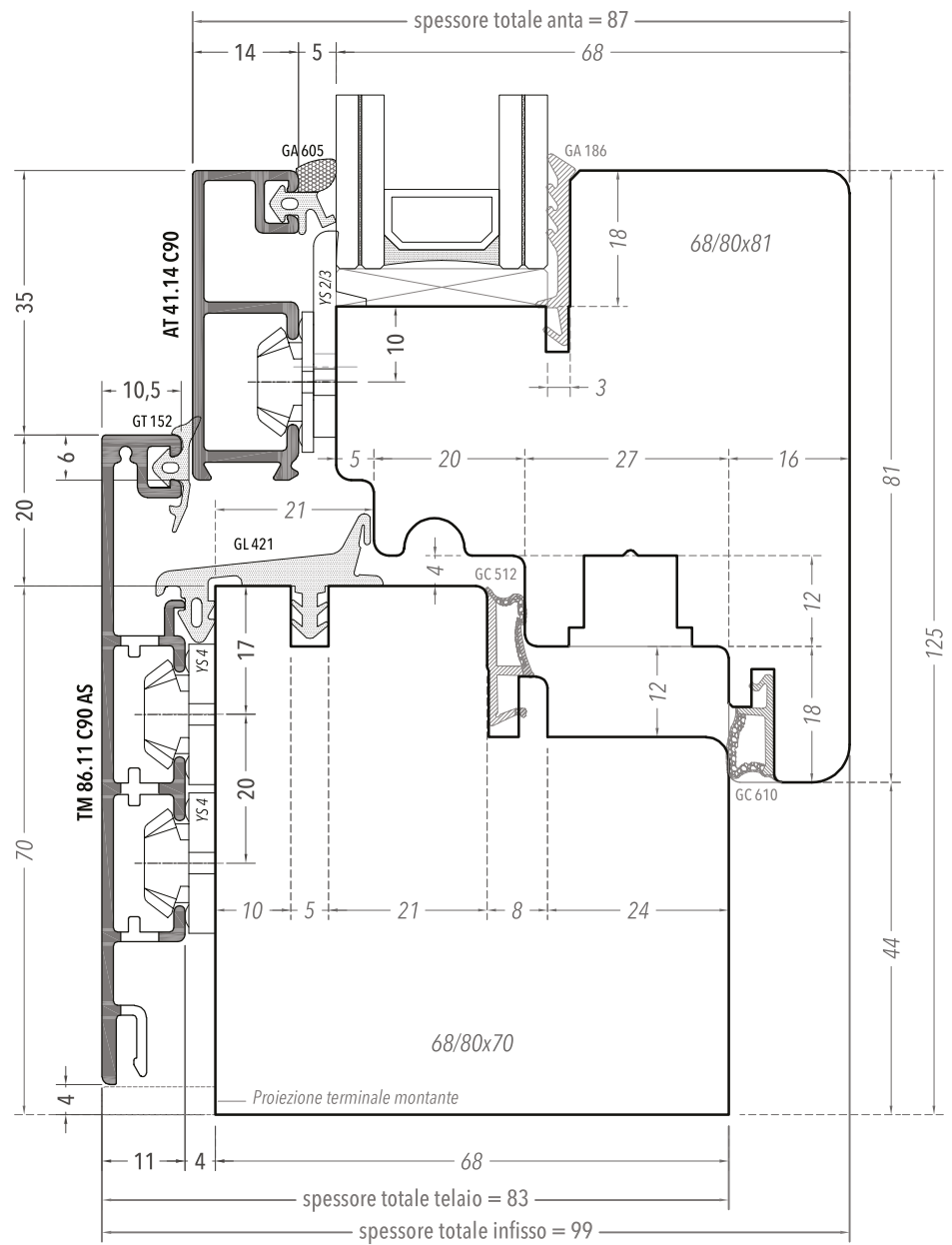
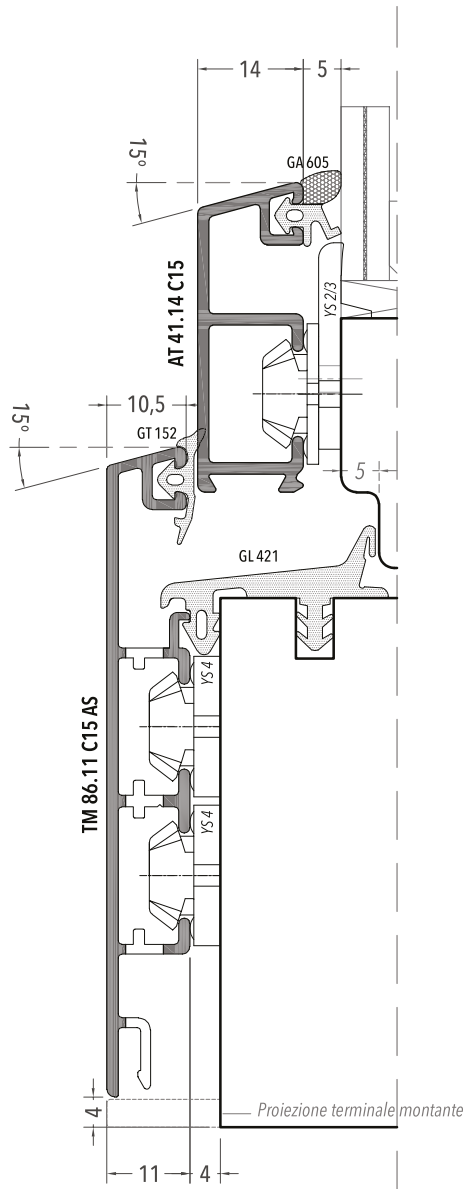

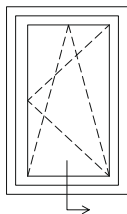

Variante traverso inferiore con profilo Slide inclinato a 15°

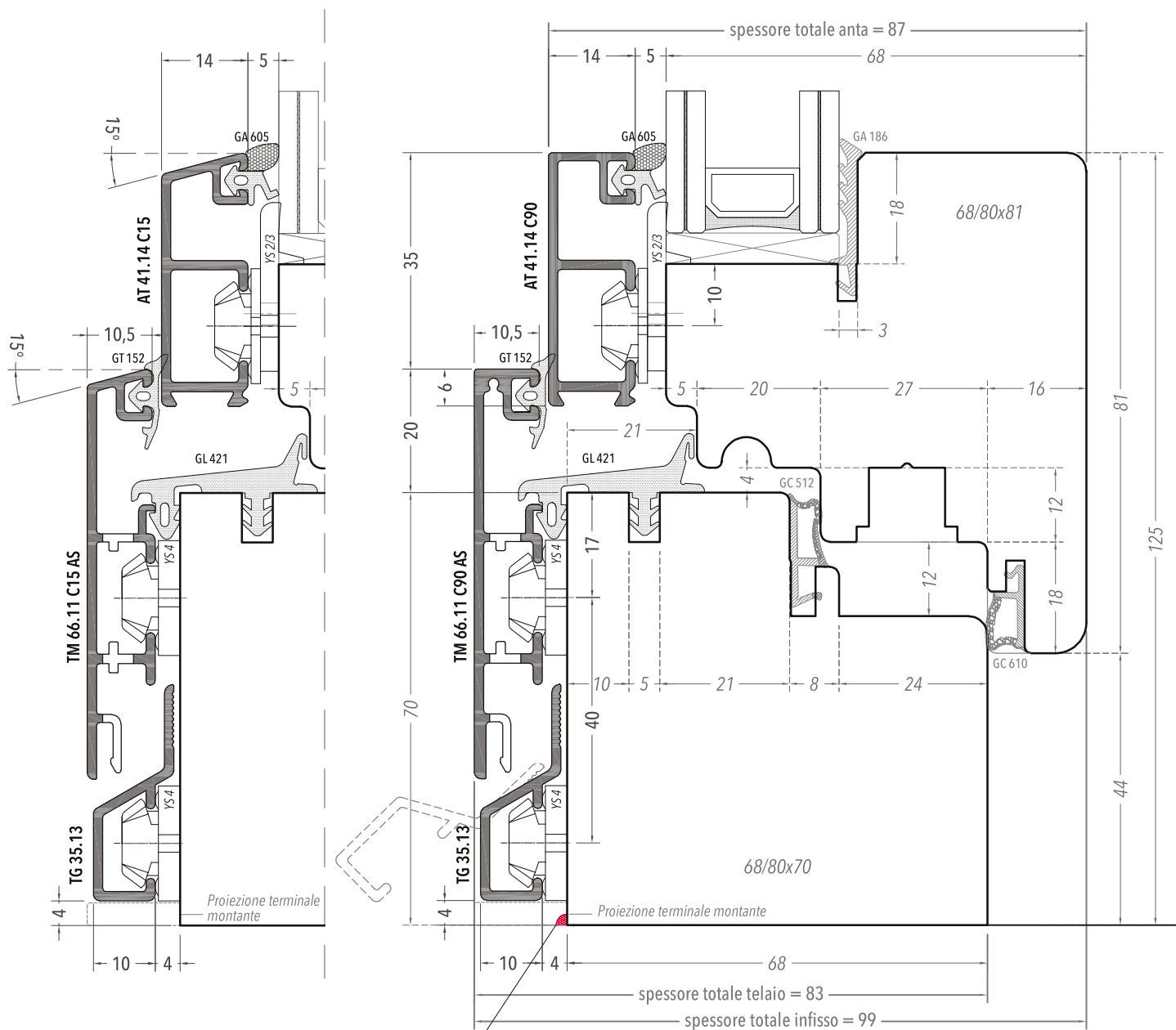

Agganciare il TG 35.13 su clip a scatto dopo aver siliconato

Variante con profilo gocciolatoio (tagliato in luce ai montanti del telaio).

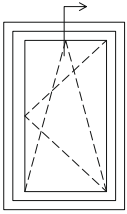

**FINESTRA**

SEZIONE VERTICALE  
NODO SUPERIORE  
SCALA 1:1

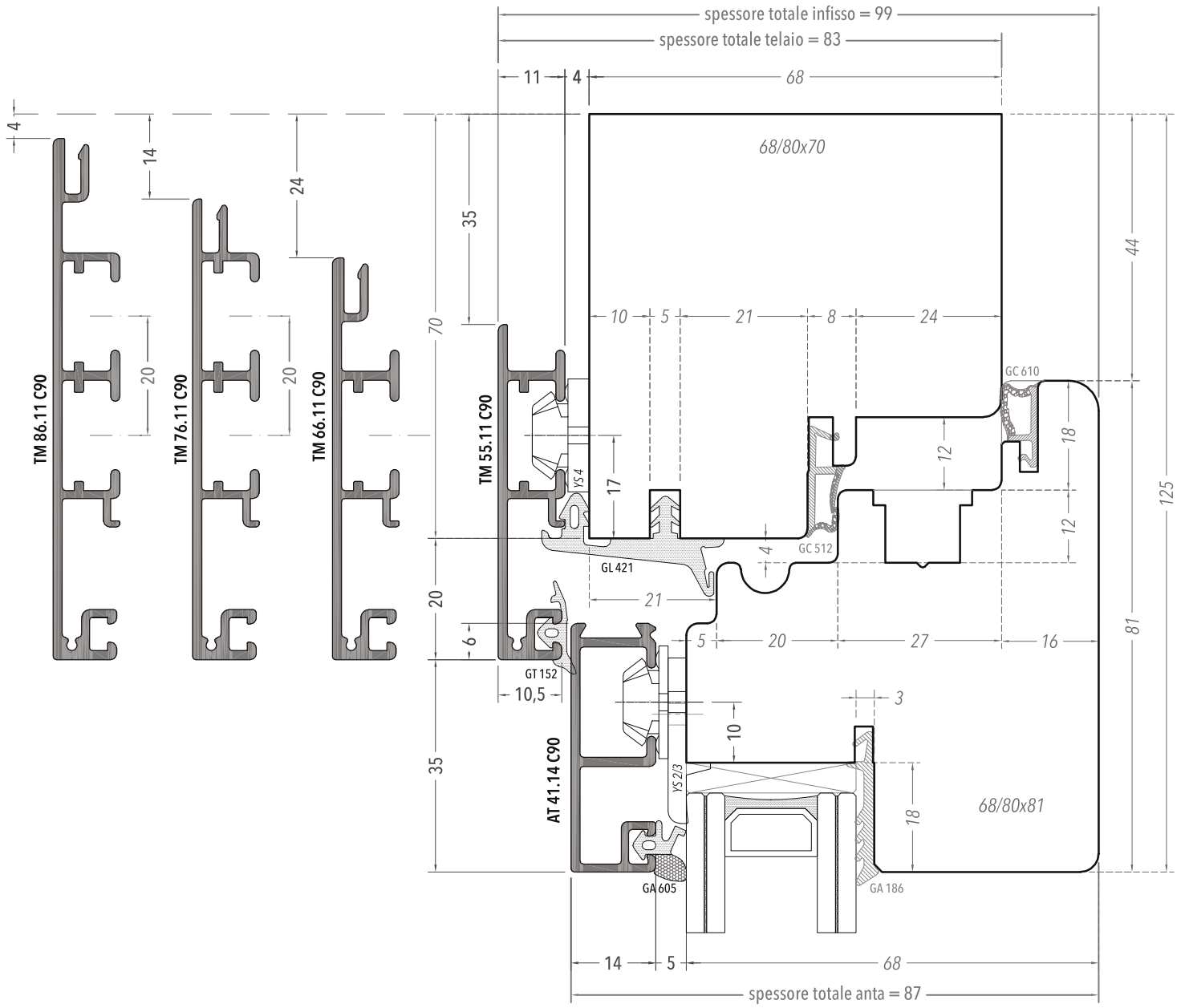

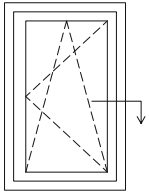

**FINESTRA**  
 SEZIONE ORIZZONTALE  
 NODO LATERALE  
 SCALA 1:1

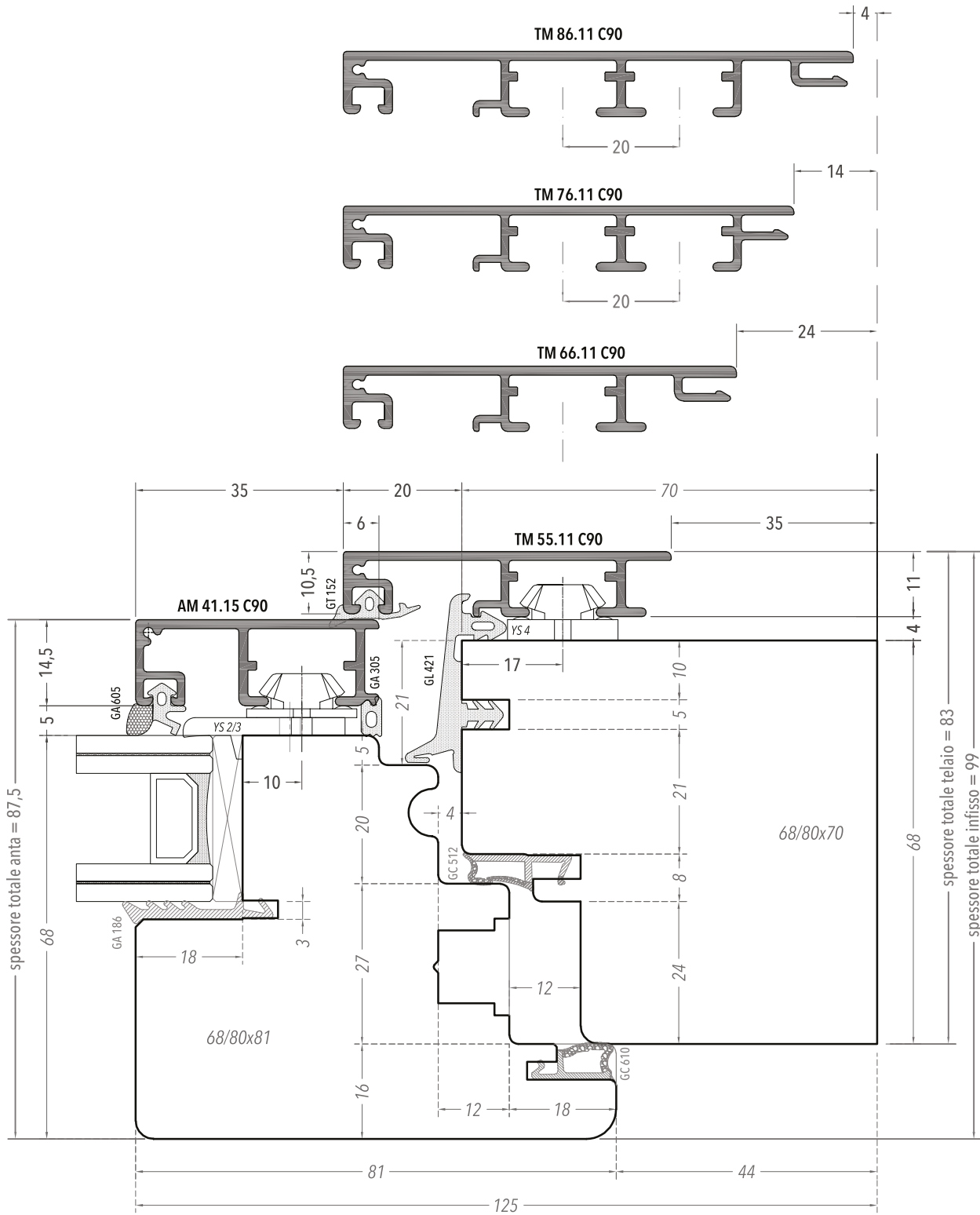

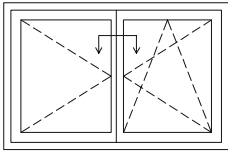

**FINESTRA**

SEZIONE ORIZZONTALE  
NODO CENTRALE  
SCALA 1:1

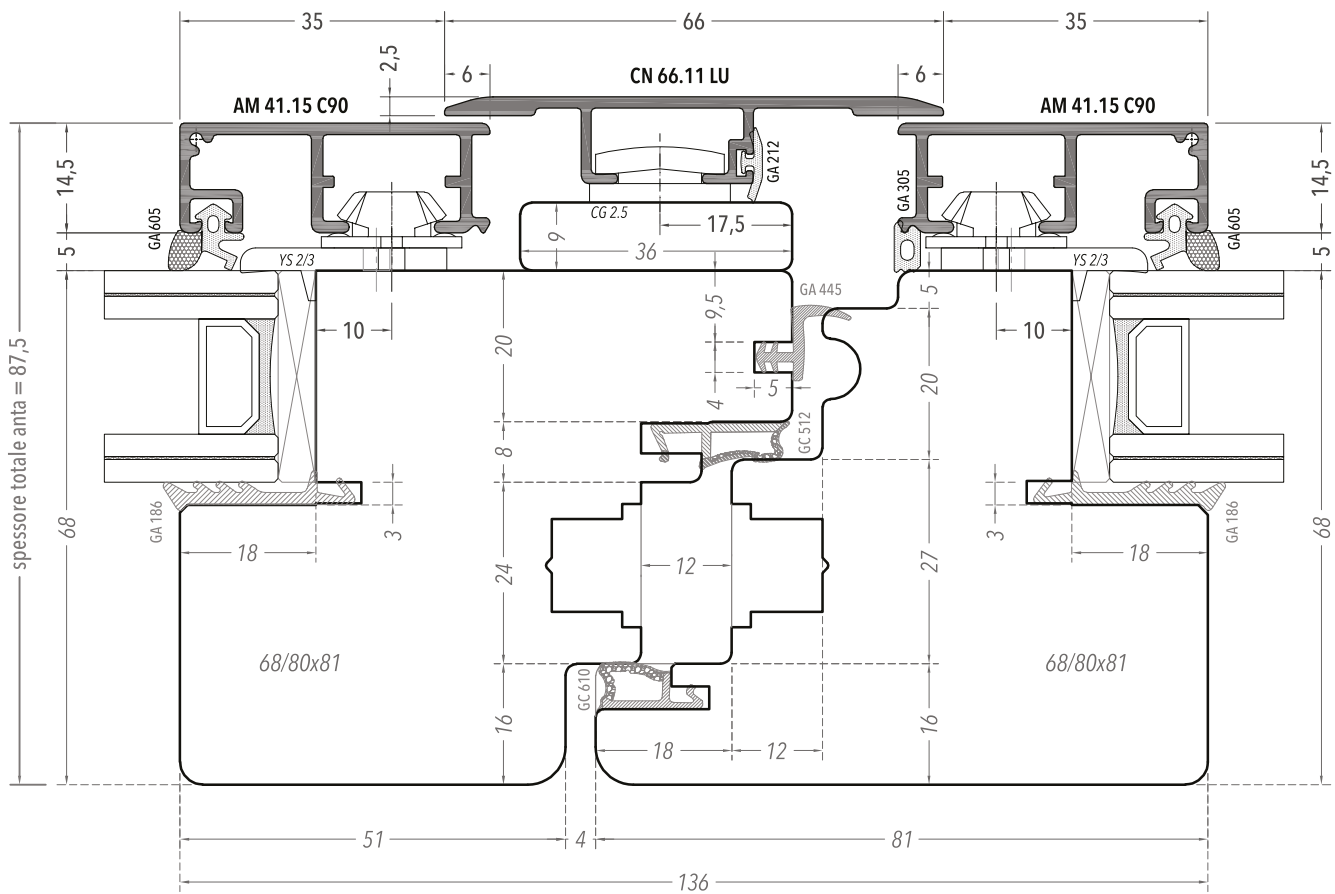
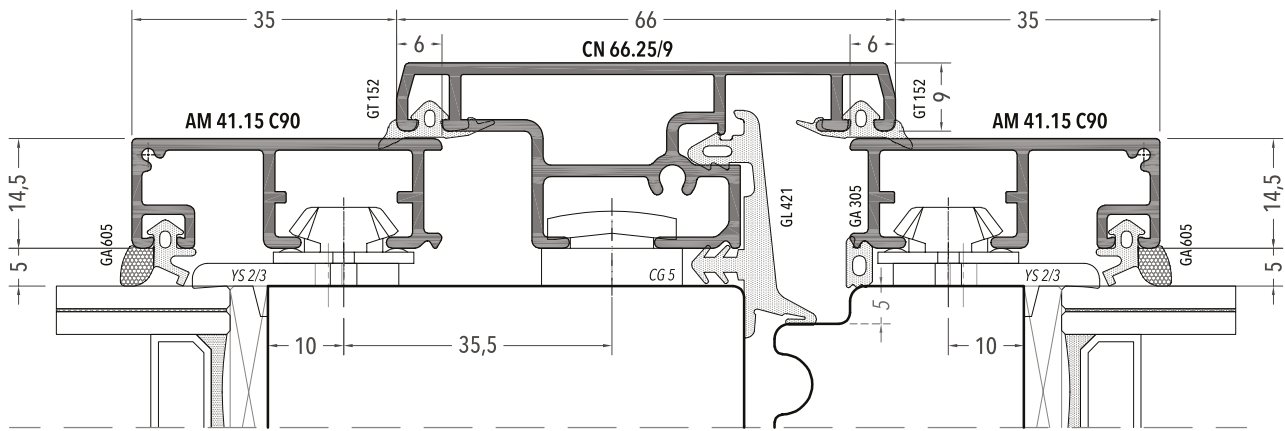

Per il disegno del nodo con montantino aggiunto consulta la pagina successiva.

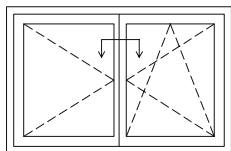

**FINESTRA**

SEZIONE ORIZZONTALE  
NODO CENTRALE CON MONTANTINO AGGIUNTO  
SCALA 1:1

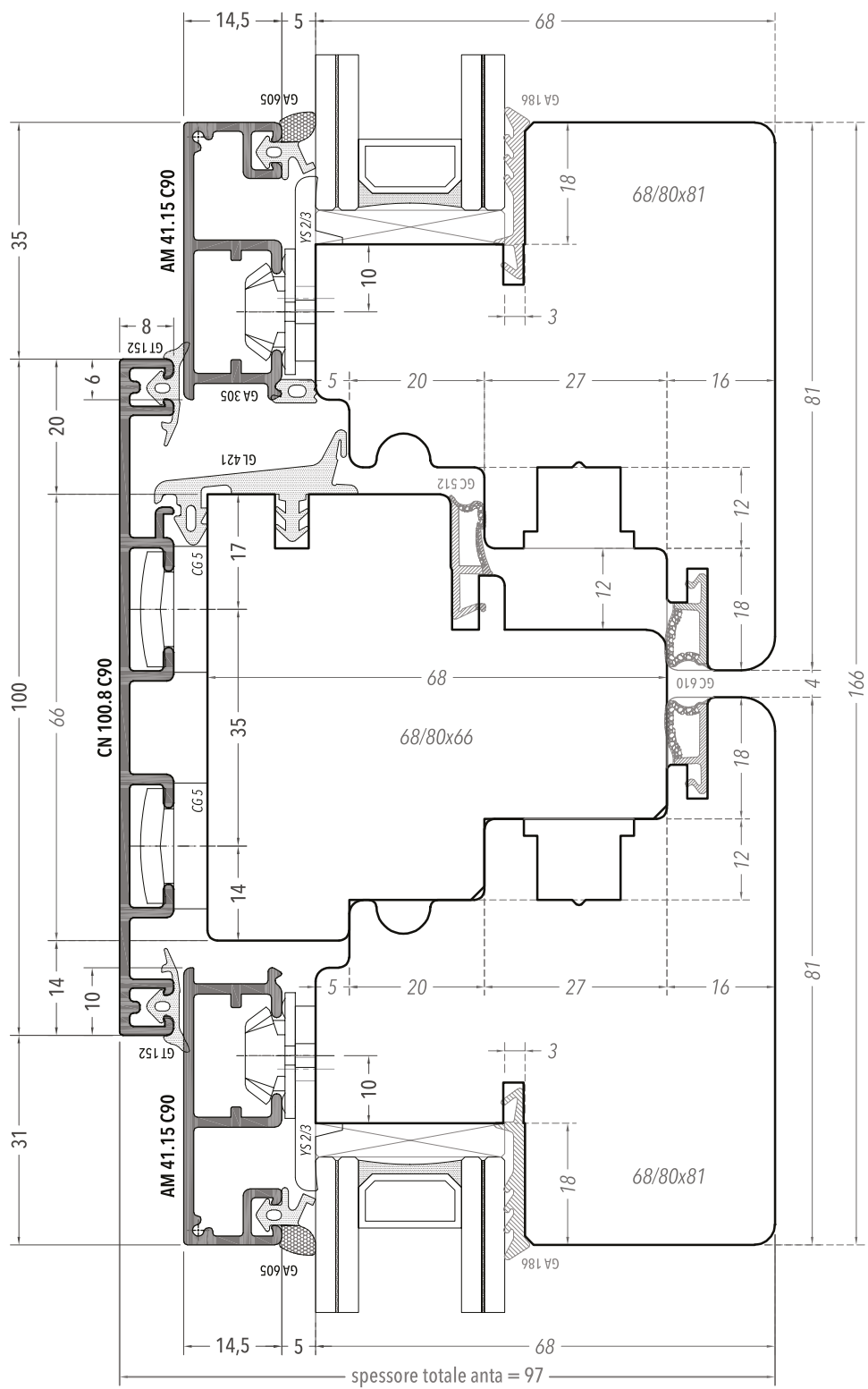

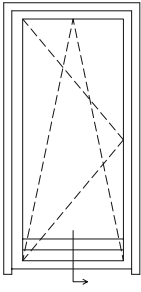

**PORTAFINESTRA**

SEZIONE VERTICALE  
NODO INFERIORE  
SCALA 1:1

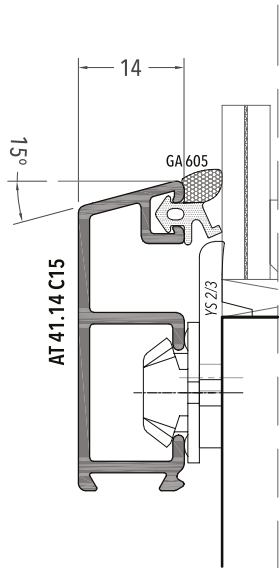

Variante con  
profilo Slide inclinato  
a 15° su traverso  
inferiore anta

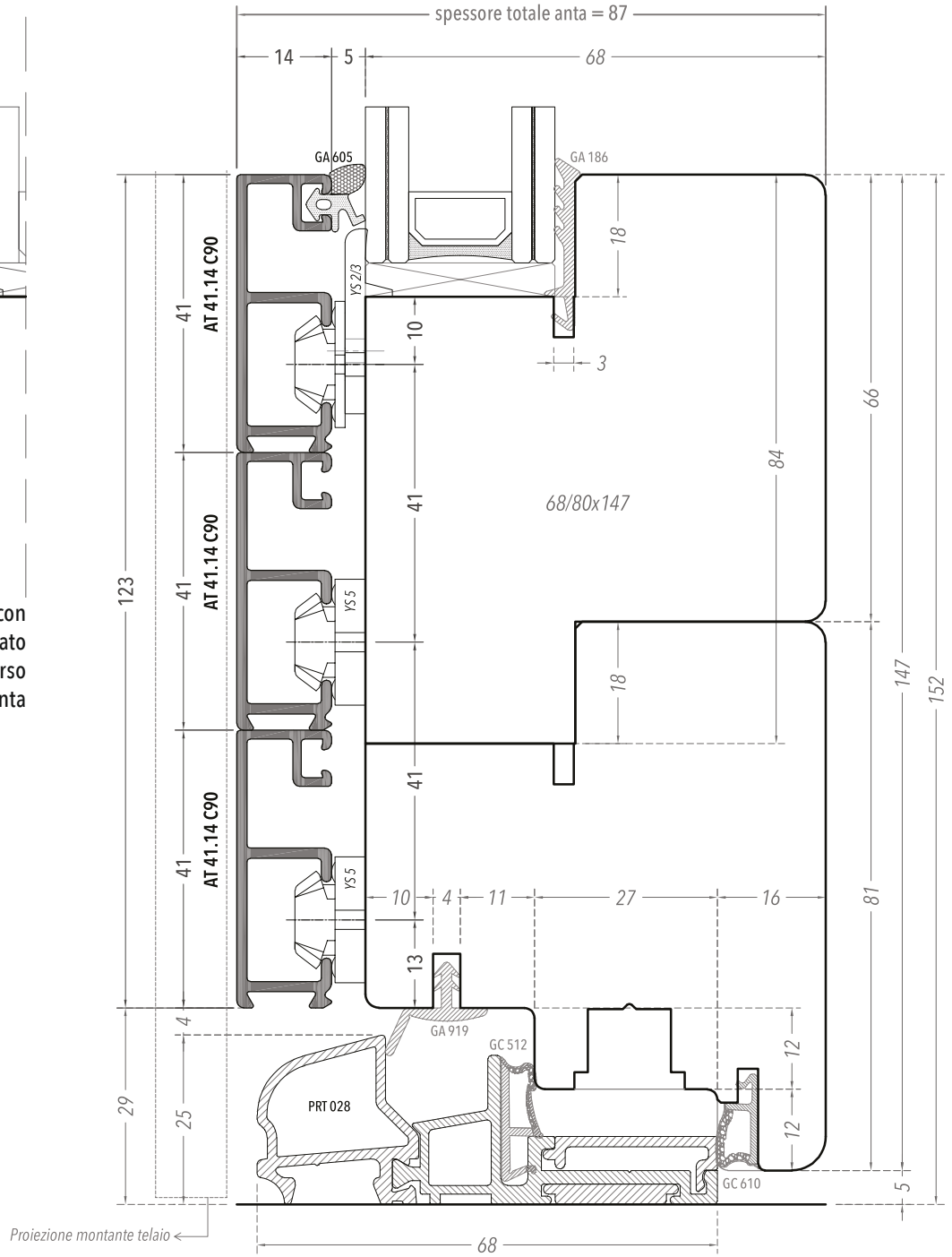

Per tutte le altre combinazioni di profili per gli zoccoli della portafinestra, consulta le pagine introduttive del catalogo.



**PORTAFINESTRA CON SERRATURA PASSANTE**

SEZIONE VERTICALE  
 NODO SUPERIORE  
 SCALA 1:1

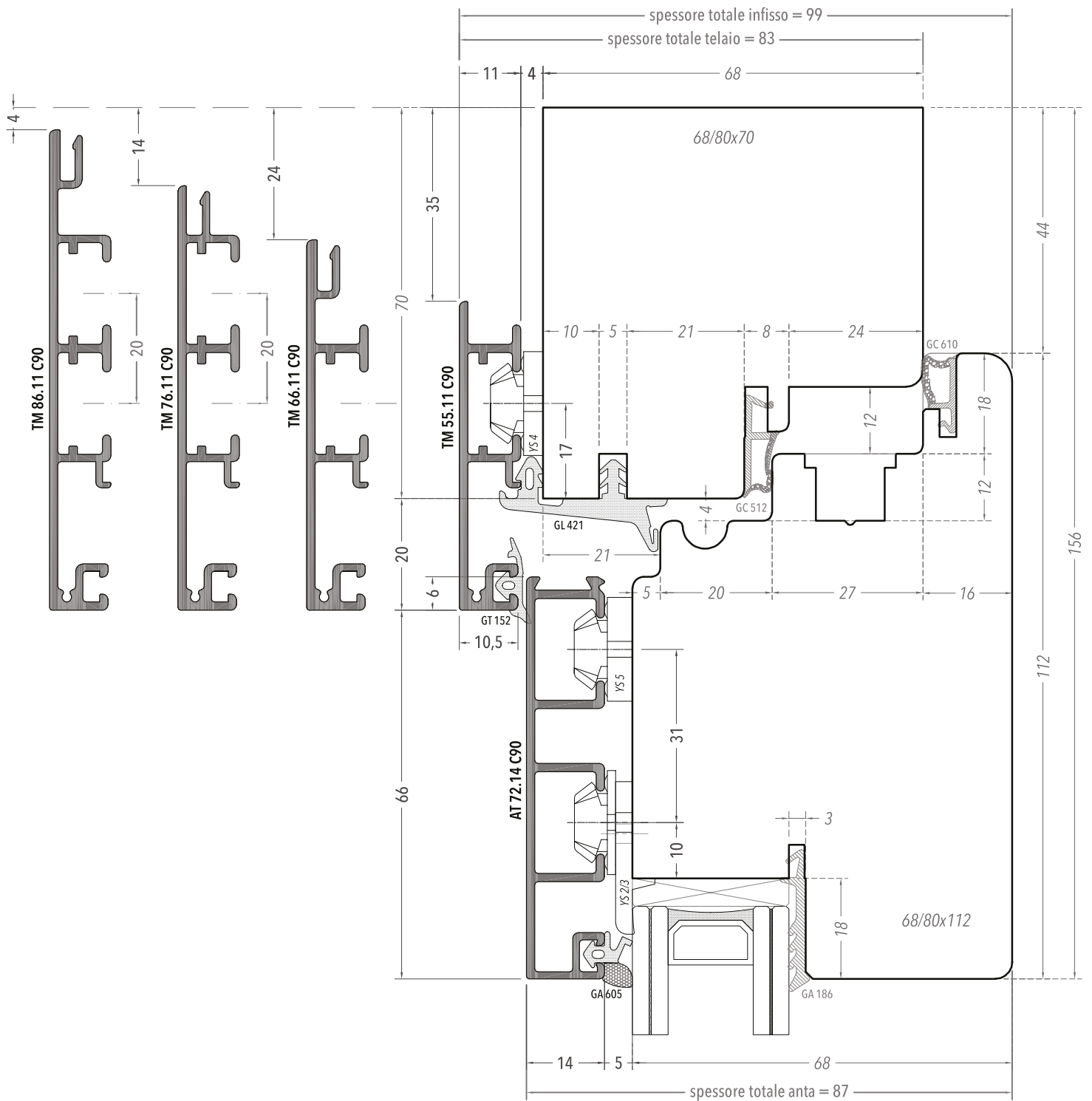
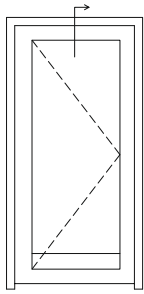

**PORTAFINESTRA CON SERRATURA PASSANTE**

SEZIONE ORIZZONTALE  
NODO LATERALE  
SCALA 1:1

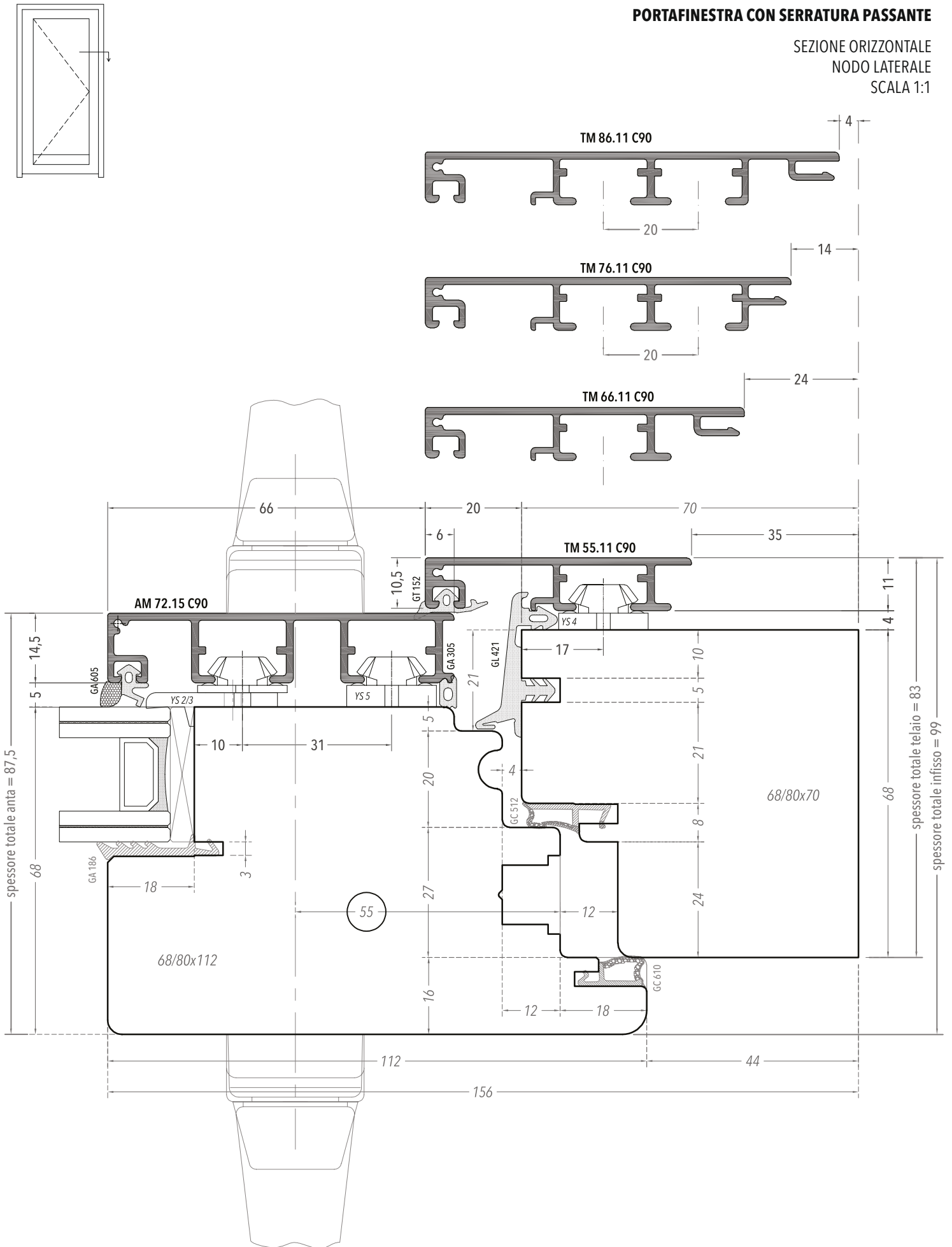

In caso di serratura passante, è possibile maggiorare solo il montante con la maniglia e lasciare invariata la sezione anta sugli altri lati. Entrata consigliata per la serratura: 55 mm.

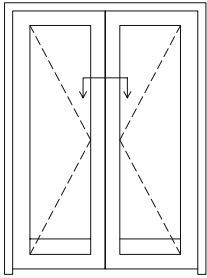

**PORTAFINESTRA CON SERRATURA PASSANTE**

SEZIONE ORIZZONTALE  
NODO CENTRALE  
SCALA 1:1

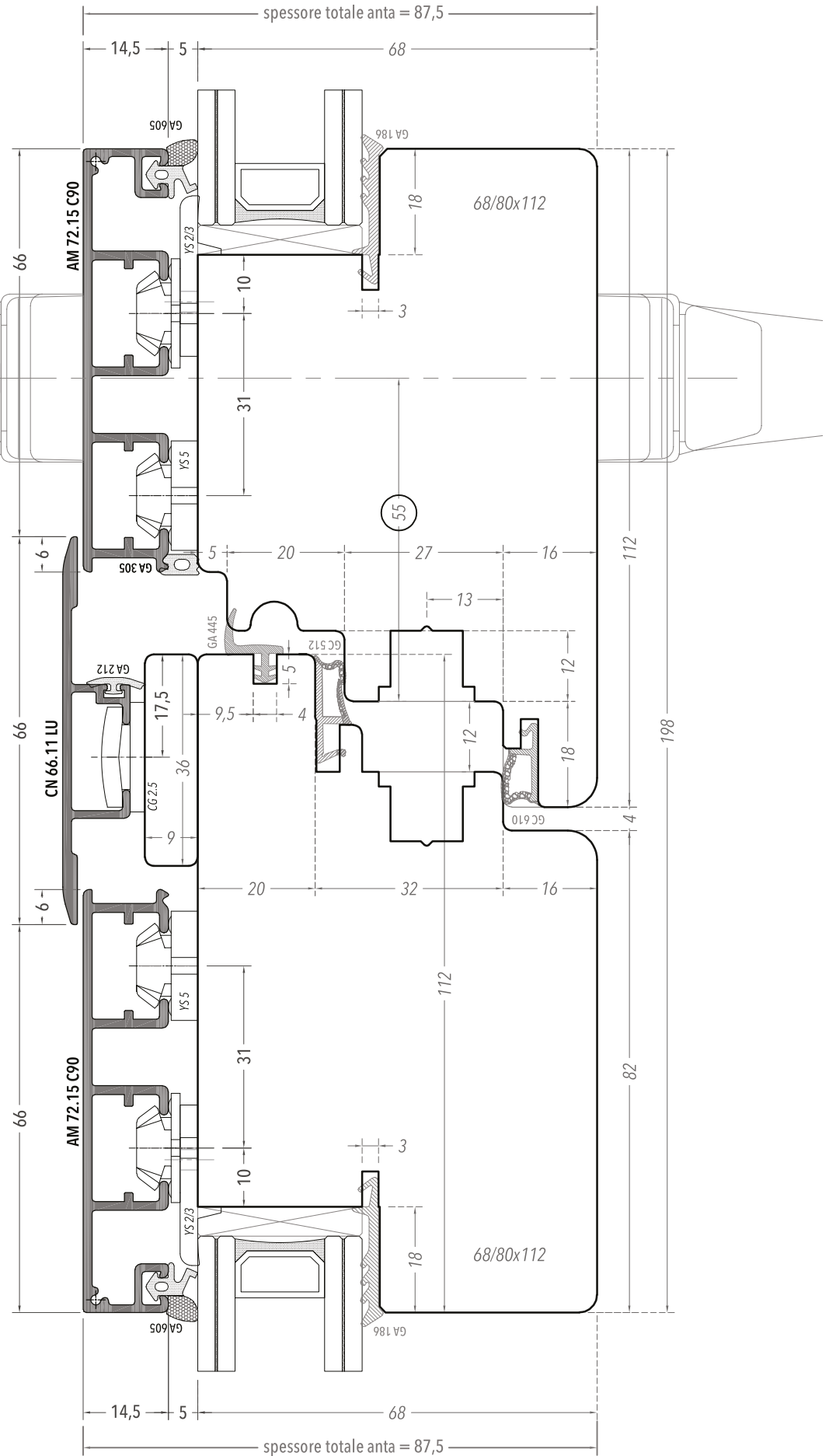
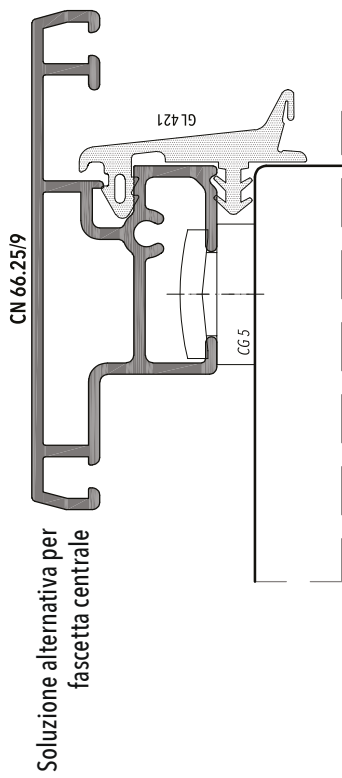

In caso di serratura passante,  
è possibile maggiorare solo  
il montante con la maniglia e  
lasciare invariata la sezione anta  
sugli altri lati.  
Entrata consigliata per la  
serratura: 55 mm.

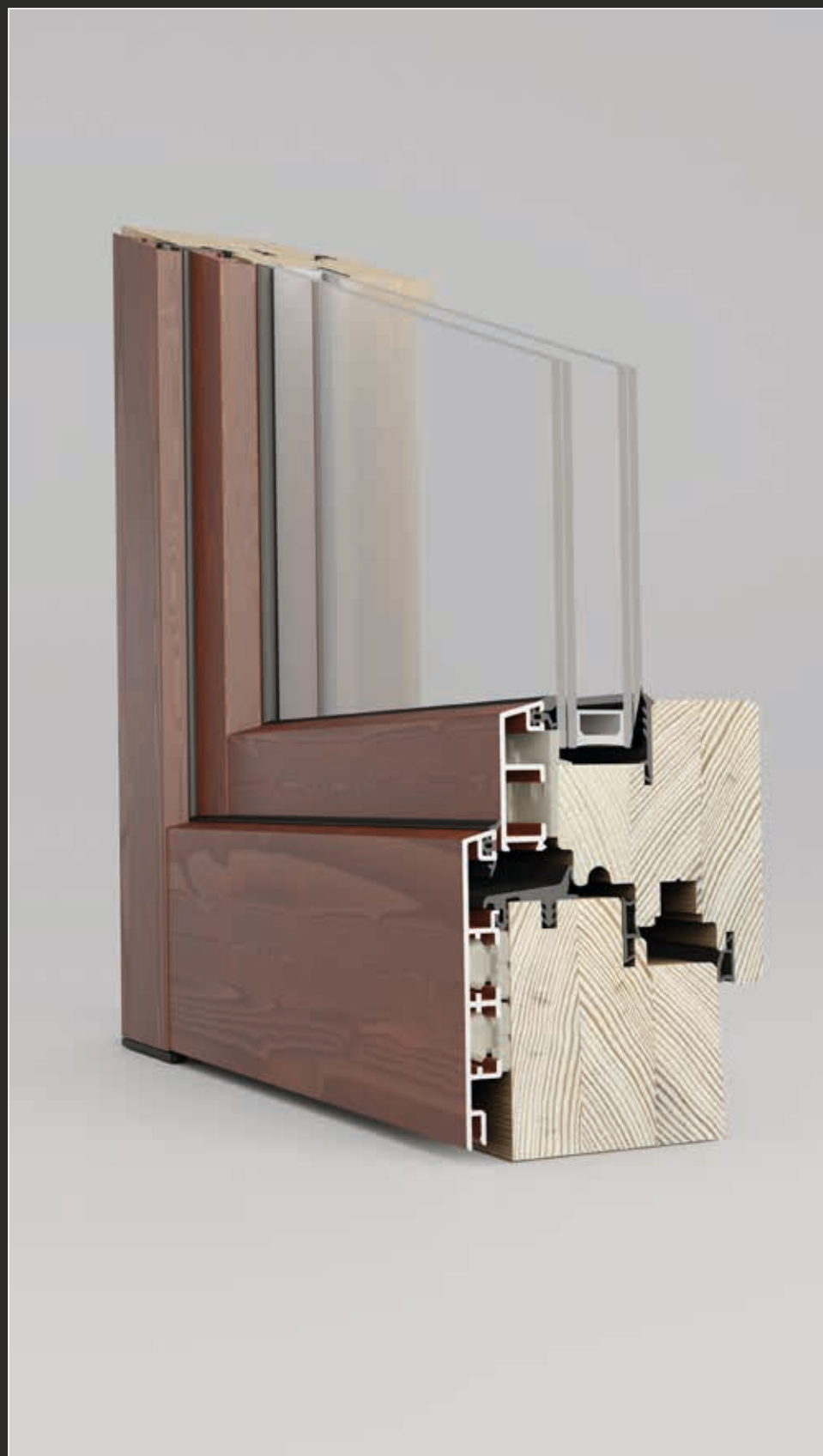

Spessore telaio 68  
Spessore anta 68  
Per serramenti Euronorm

# Alumfast Sistema 21

---

SLIDE

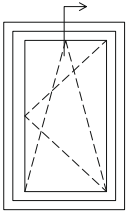

**FINESTRA**

SEZIONE VERTICALE  
NODO SUPERIORE  
SCALA 1:1

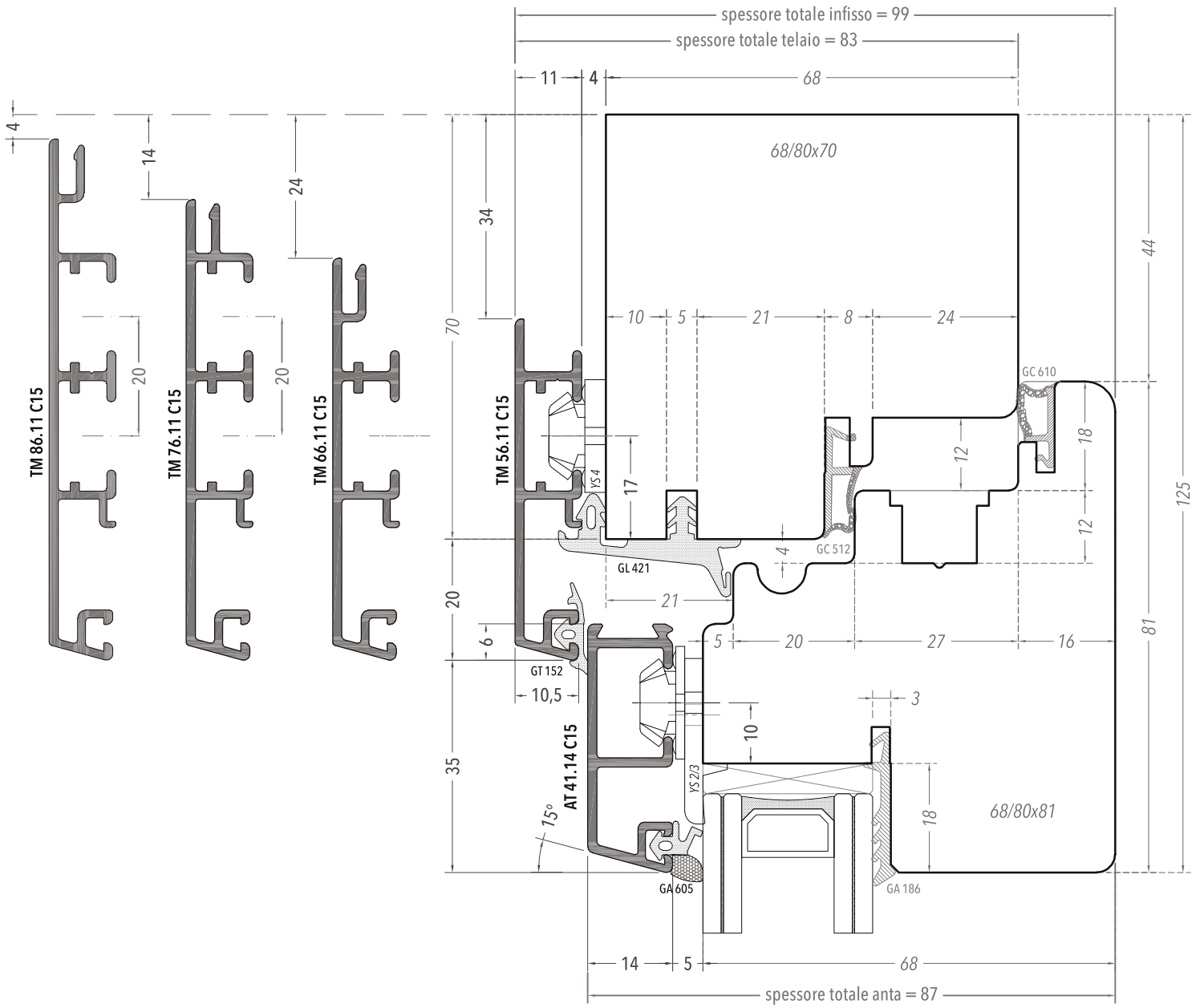

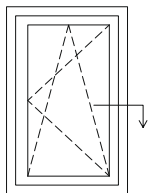

**FINESTRA**

SEZIONE ORIZZONTALE  
NODO LATERALE  
SCALA 1:1

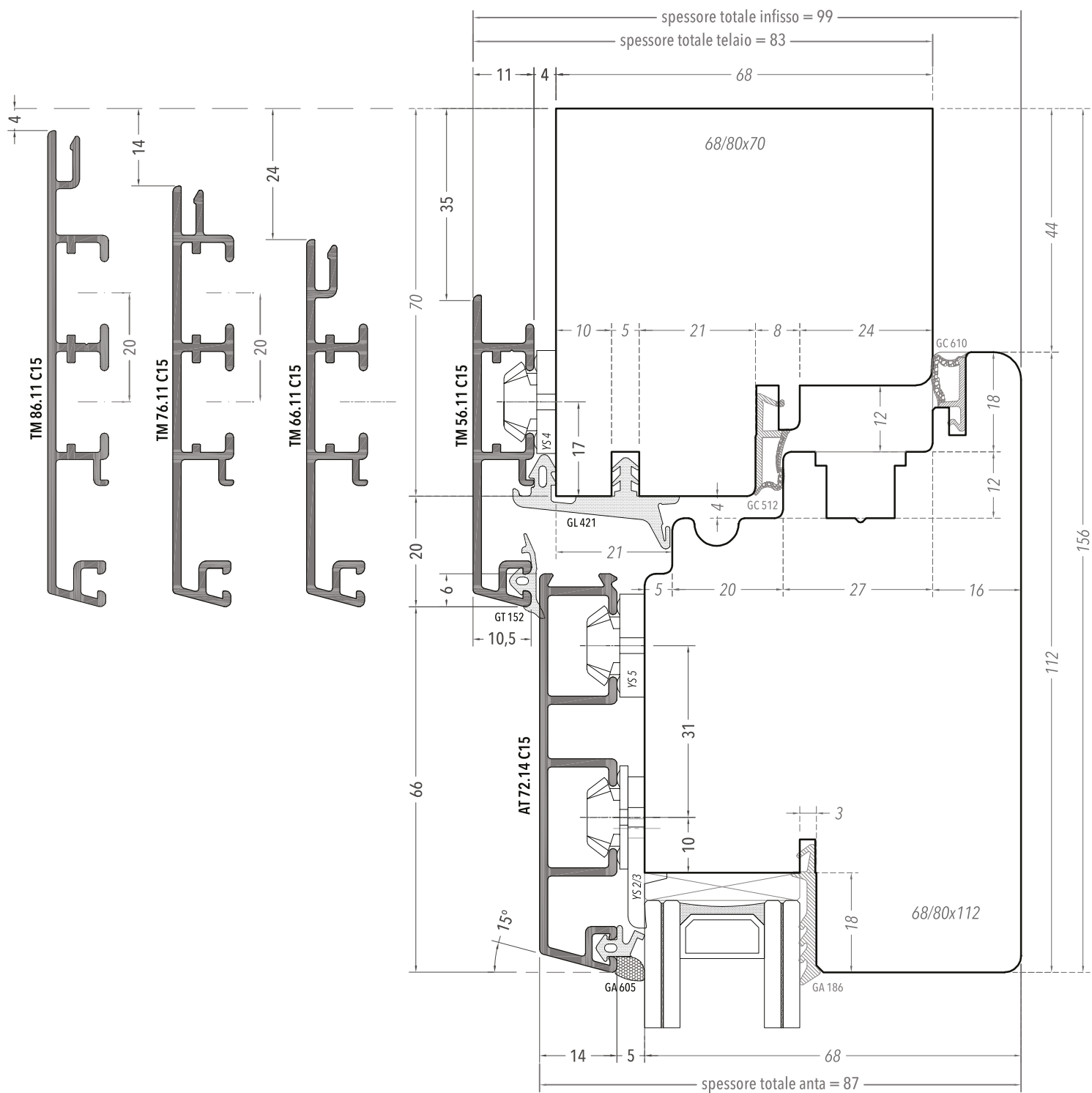

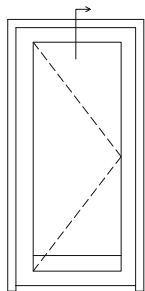

**PORTAFINESTRA CON SERRATURA PASSANTE**

SEZIONE VERTICALE  
 NODO SUPERIORE  
 SCALA 1:1

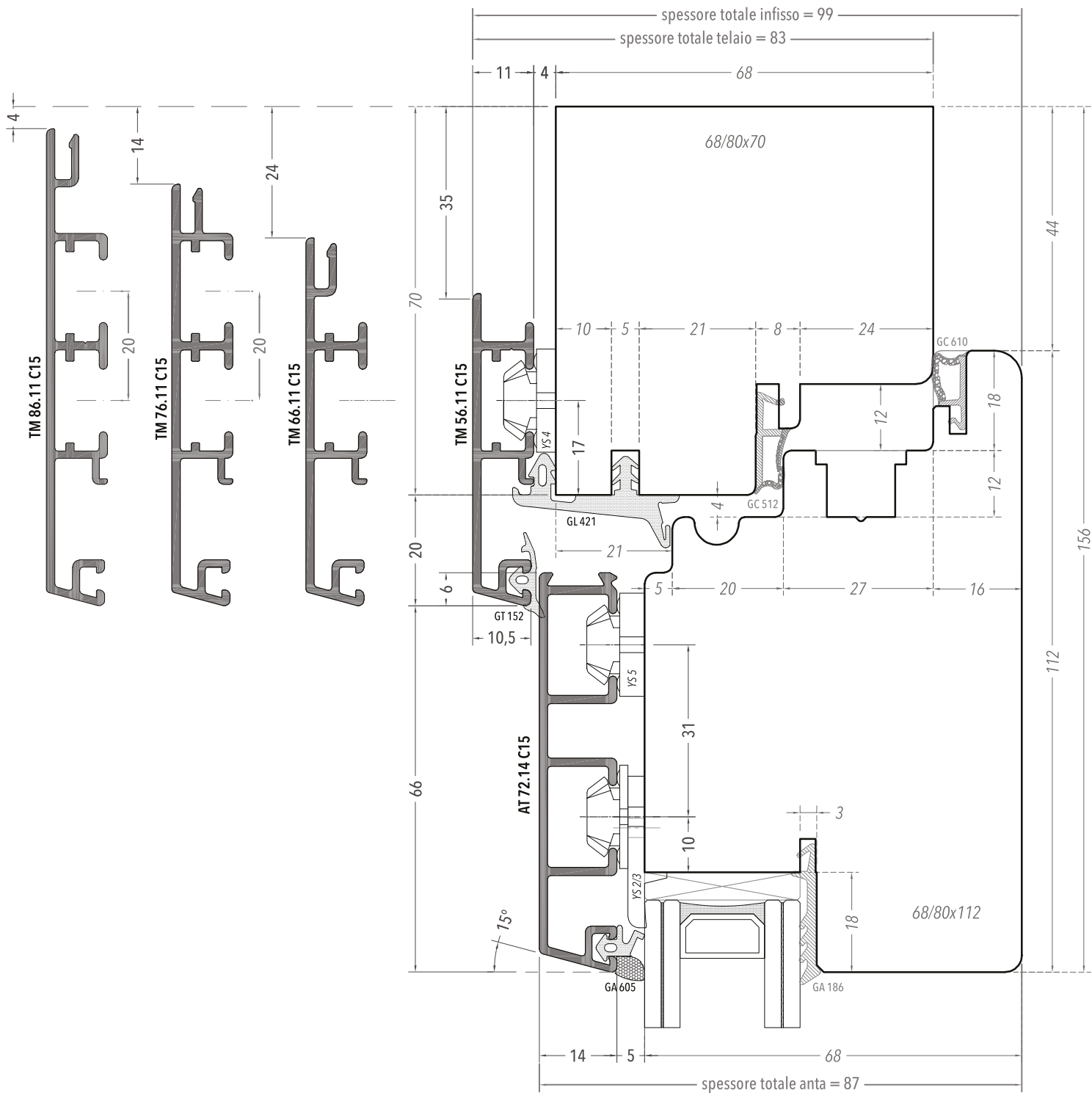



**PORTAFINESTRA CON SERRATURA PASSANTE**

SEZIONE ORIZZONTALE  
NODO LATERALE  
SCALA 1:1

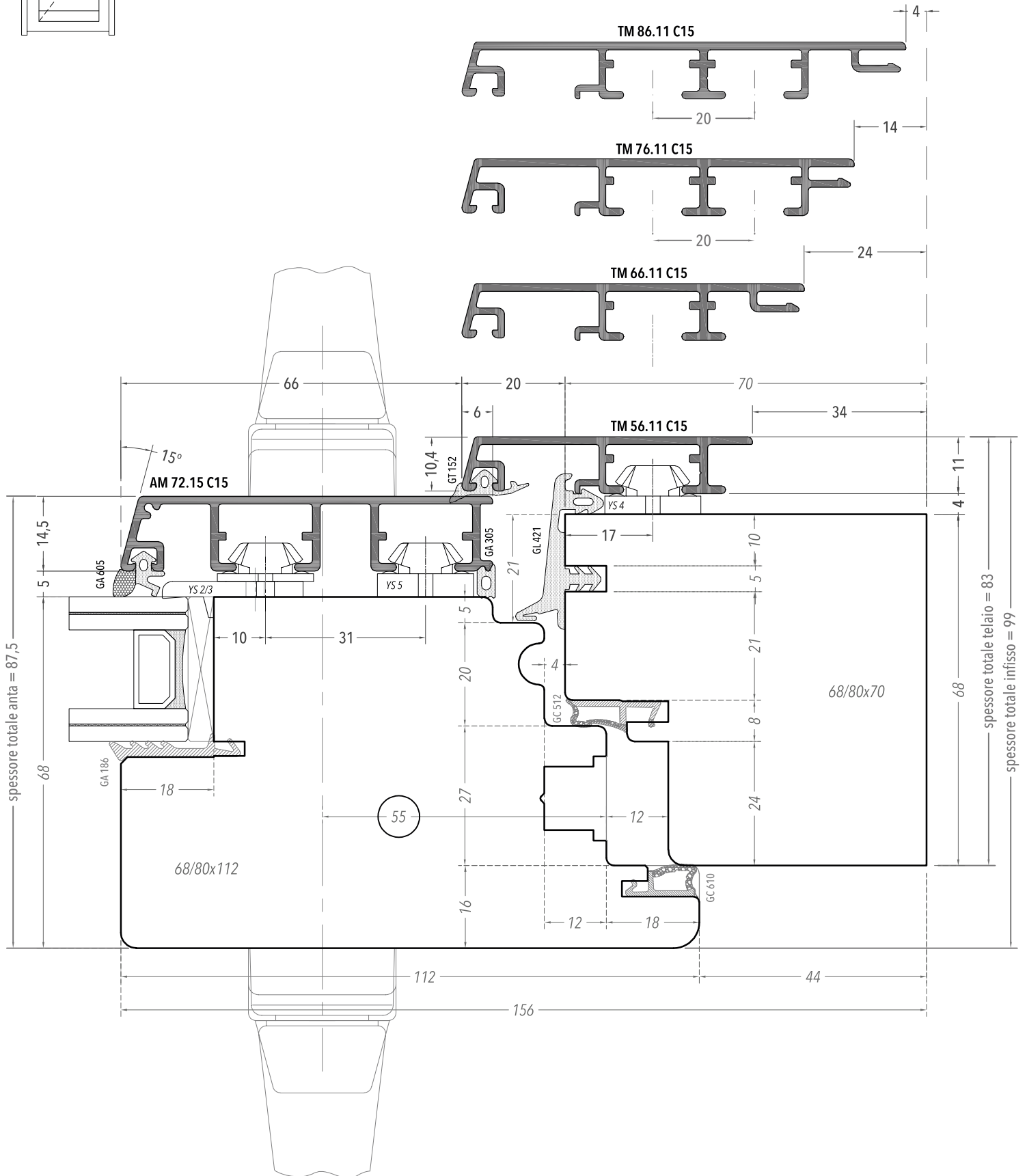
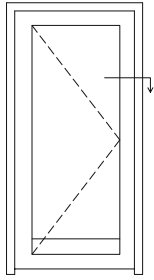

Entrata consigliata per la serratura: 55 mm.



Spessore telaio 65  
Spessore anta 68  
Per serramenti Freumex

# Alumfast Sistema 16

---

STANDARD

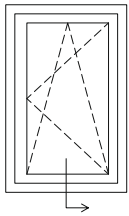

**FINESTRA**

SEZIONE VERTICALE  
NODO INFERIORE  
SCALA 1:1

Variante traverso  
inferiore con profilo  
Slide inclinato a 15°

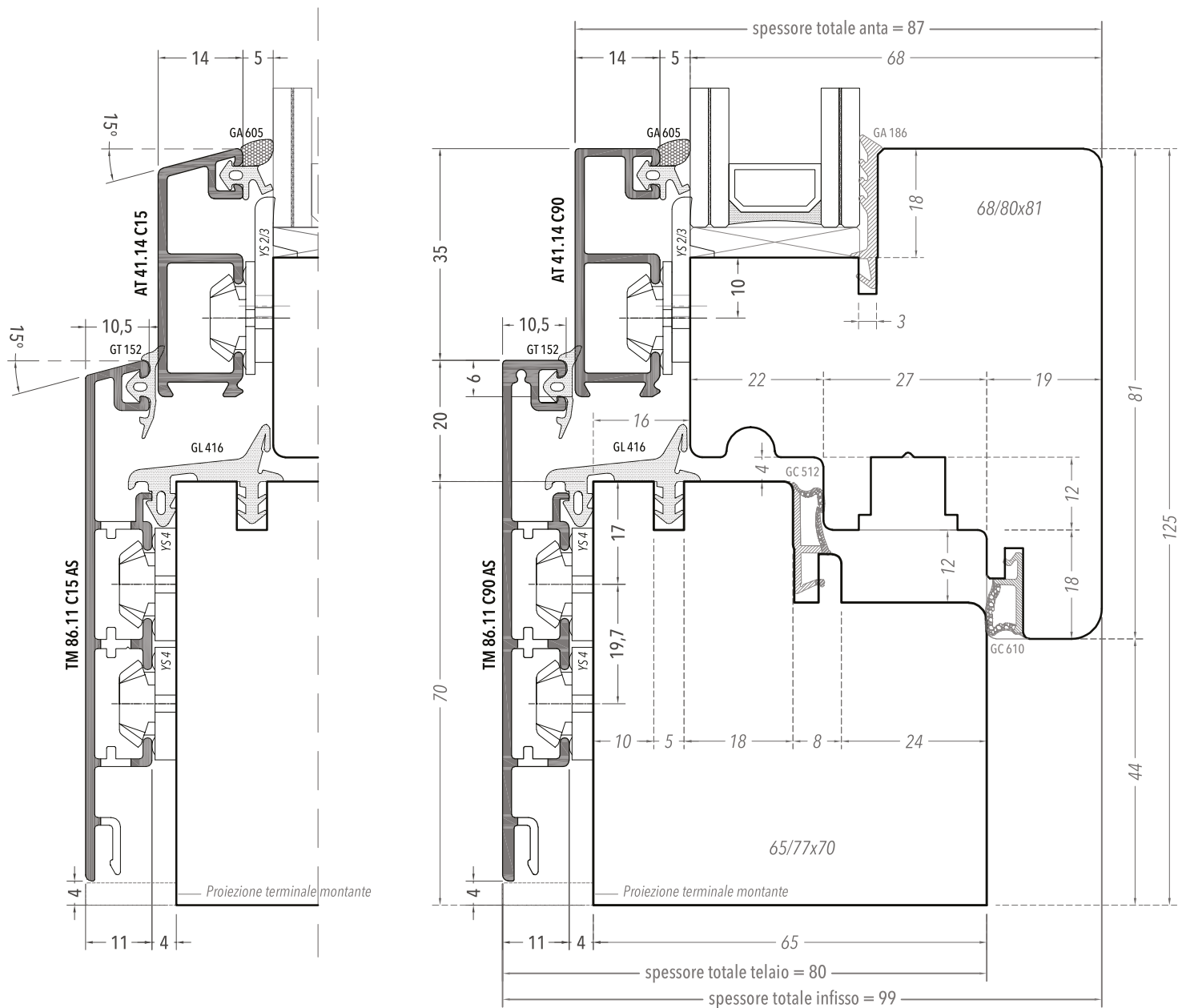

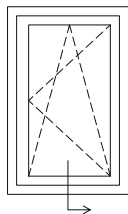

Variante trasverso  
inferiore con profilo  
Slide inclinato a 15°

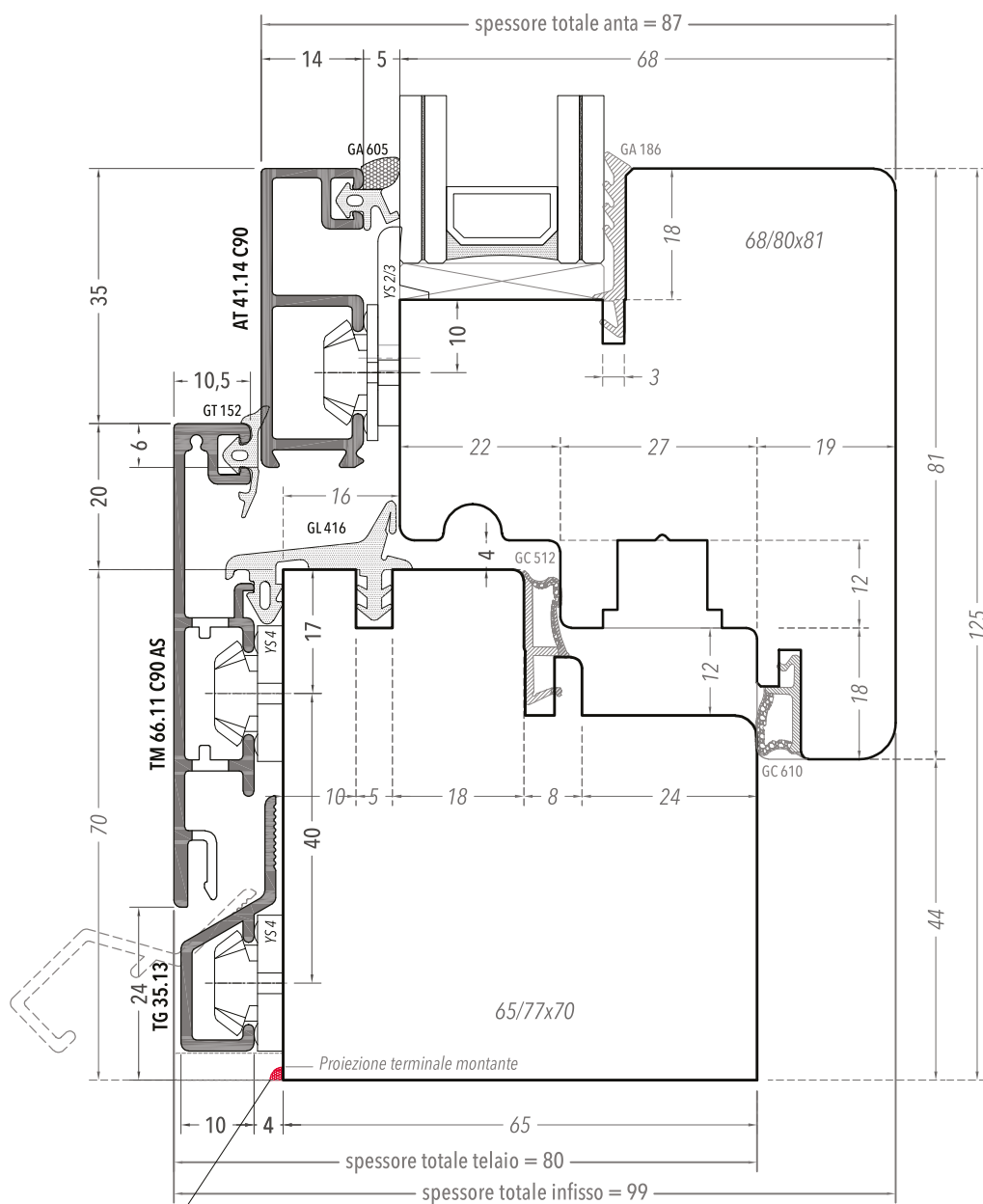
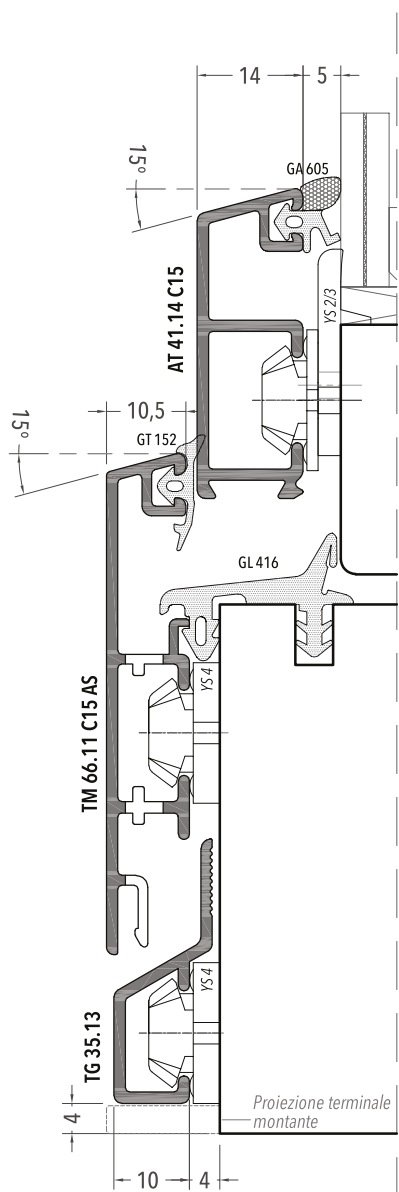

Agganciare il TG 35.13 su clip a scatto dopo aver siliconato

Variante con profilo gocciolatoio (tagliato in luce ai montanti del telaio).

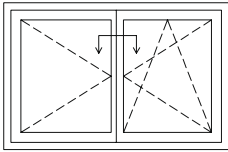

**FINESTRA**

SEZIONE ORIZZONTALE  
 NODO CENTRALE  
 SCALA 1:1

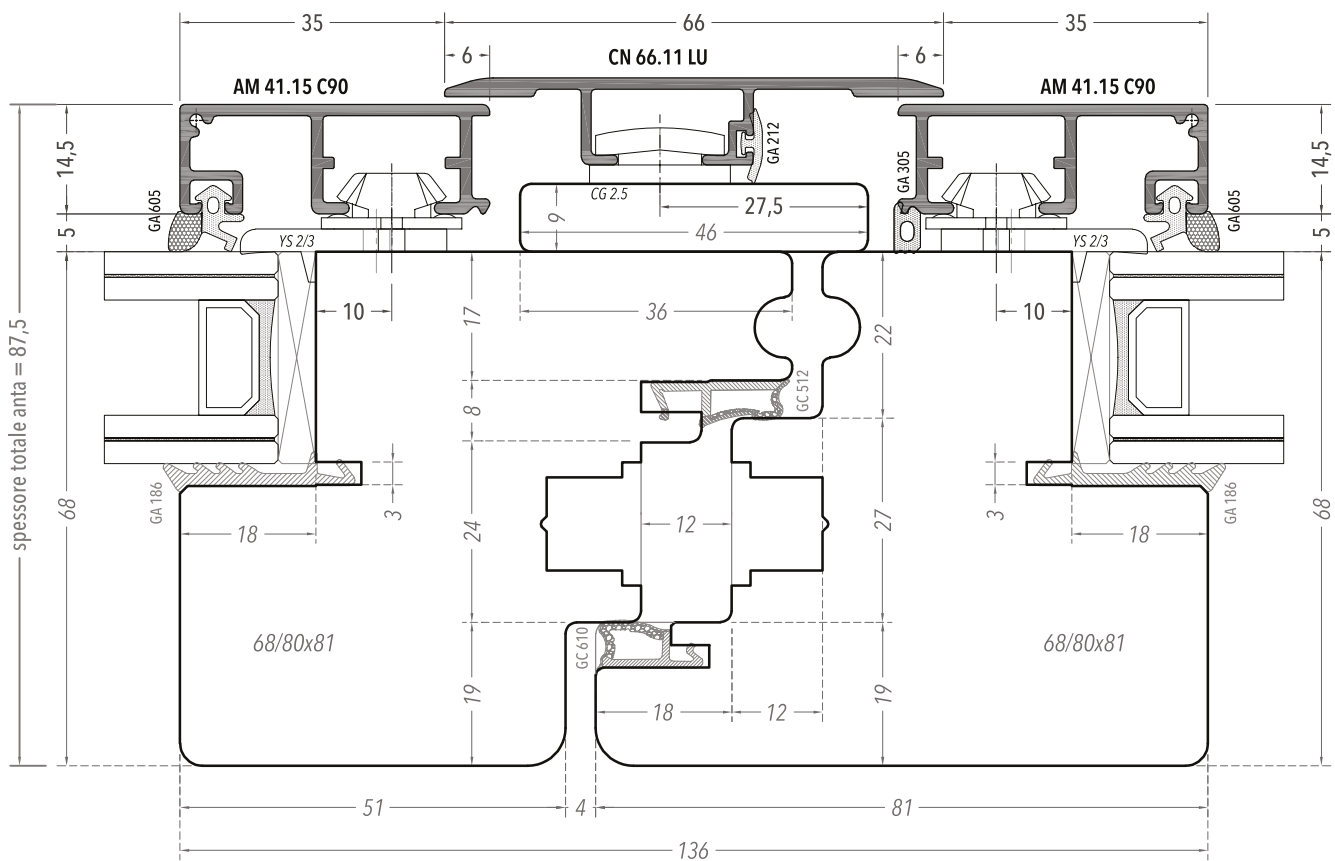
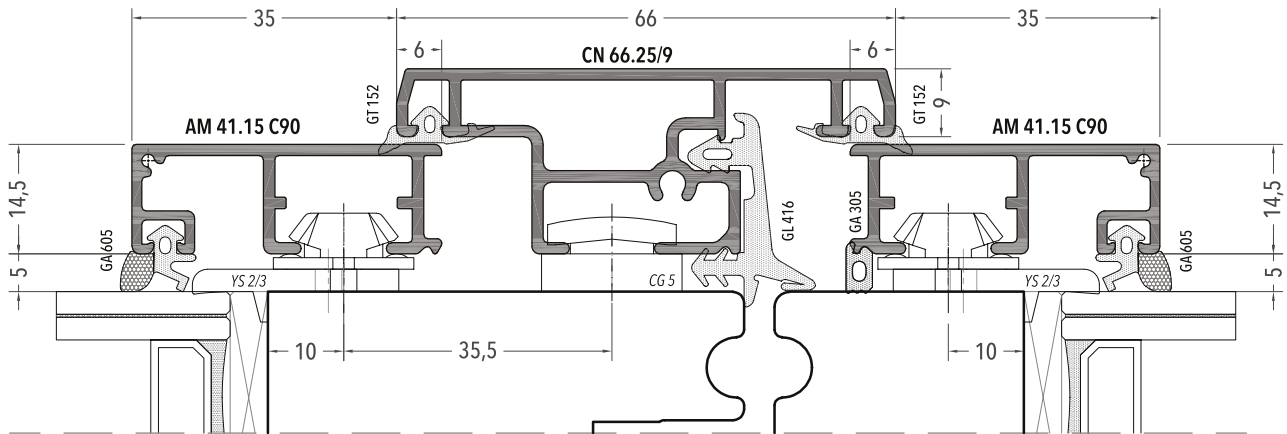

Per il disegno con montantino aggiunto, consulta la pagina successiva.

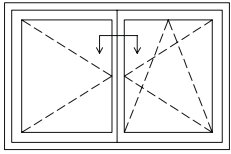

**FINESTRA**

SEZIONE ORIZZONTALE  
NODO CENTRALE CON MONTANTINO AGGIUNTO  
SCALA 1:1

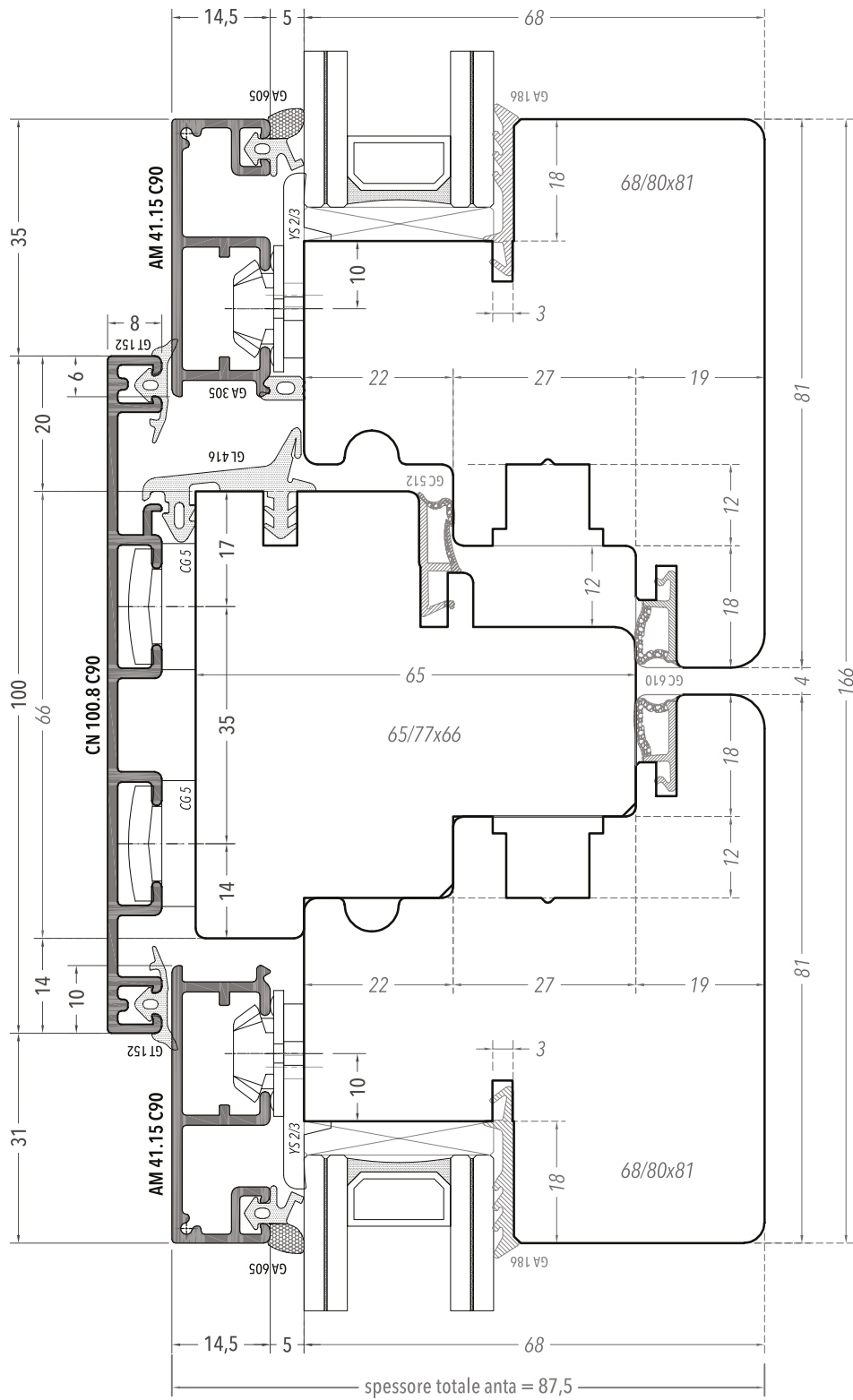



Spessore telaio 65  
Spessore anta 68  
Per serramenti Freumex



# Alumfast Sistema 16

---

SLIDE

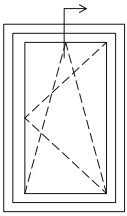

**FINESTRA**

SEZIONE VERTICALE  
NODO SUPERIORE  
SCALA 1:1

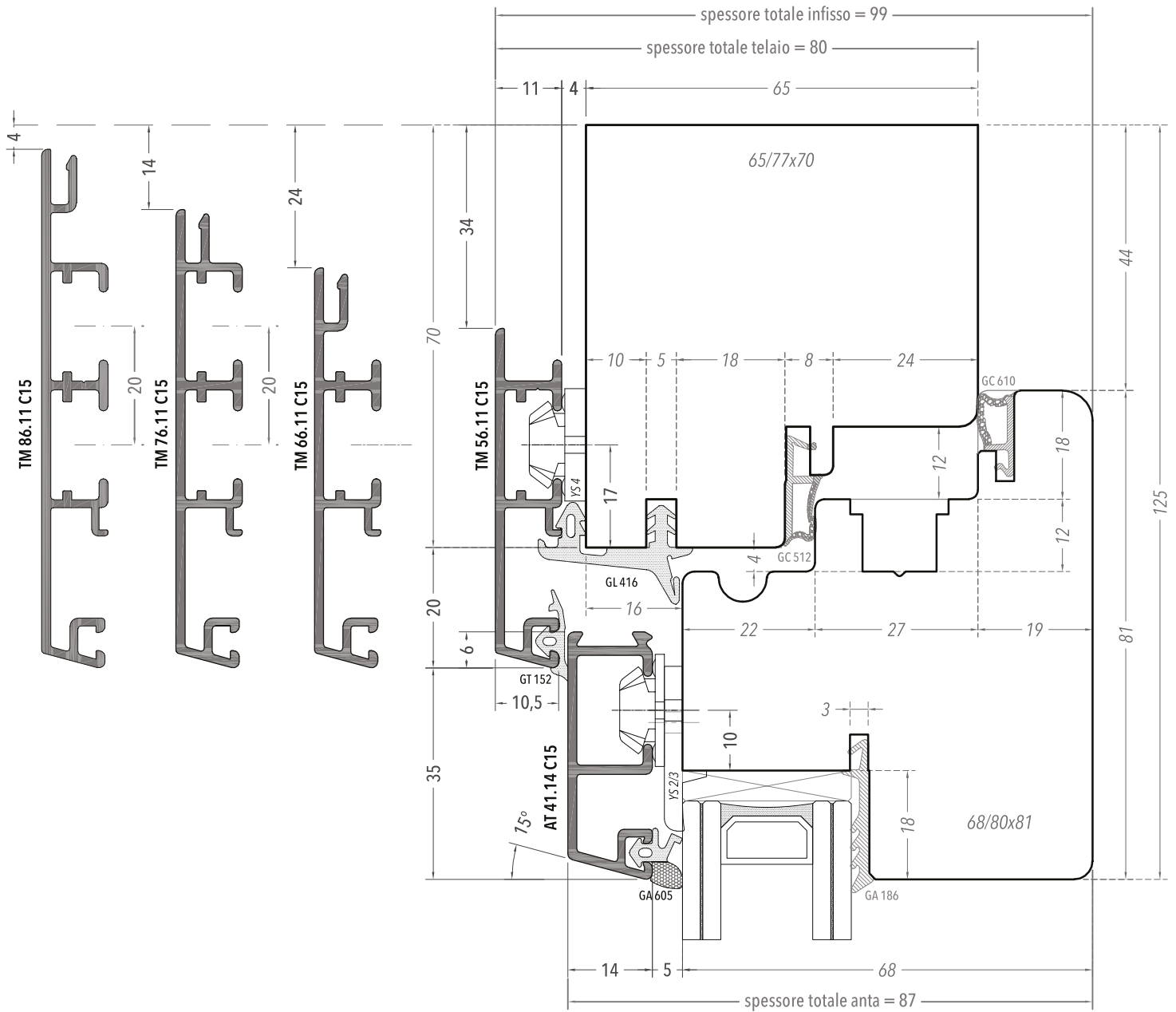

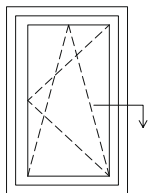

**FINESTRA**

SEZIONE ORIZZONTALE  
 NODO LATERALE  
 SCALA 1:1

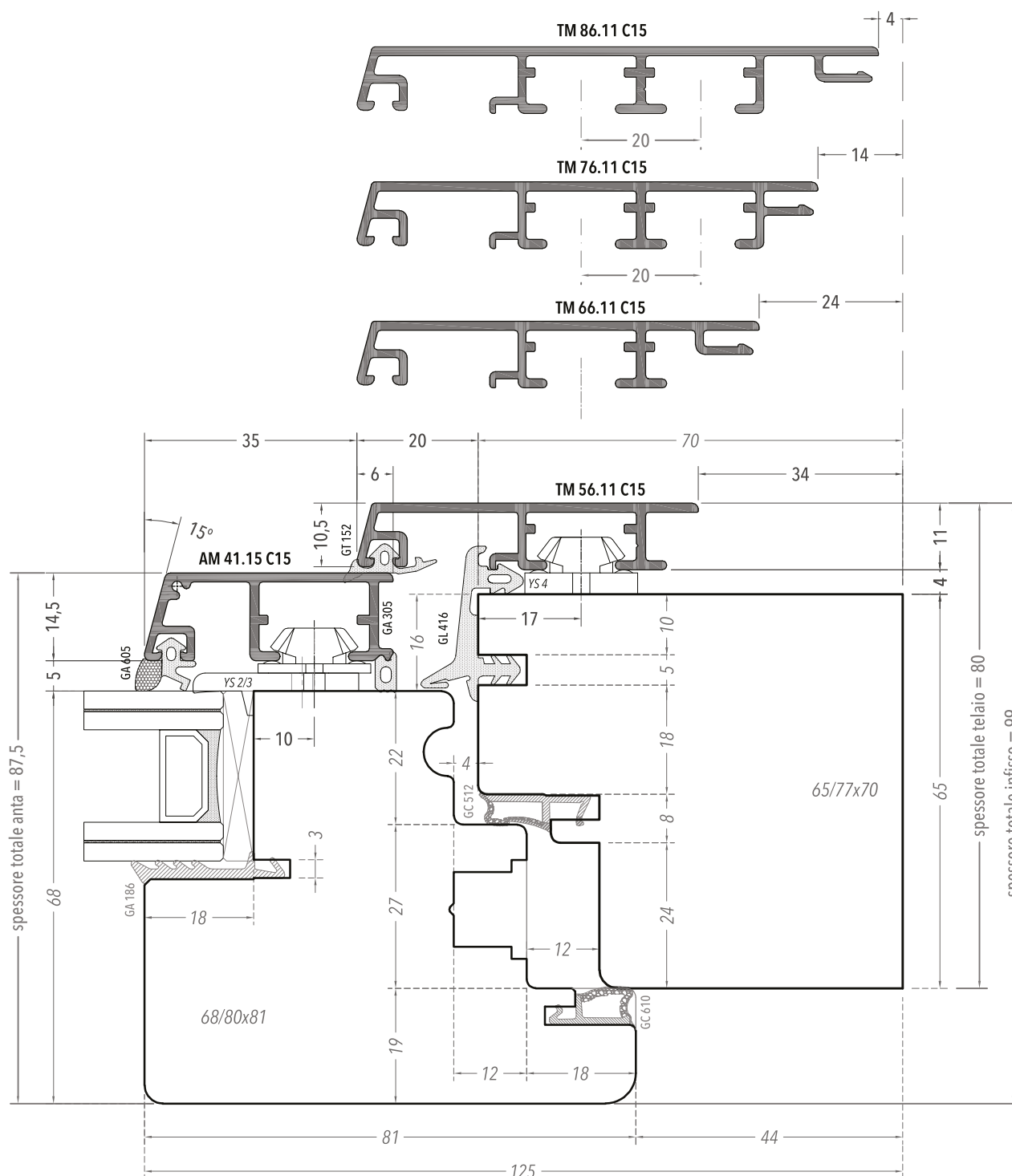

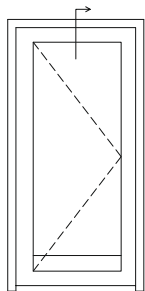

**PORTAFINESTRA CON SERRATURA PASSANTE**

SEZIONE VERTICALE  
NODO SUPERIORE  
SCALA 1:1

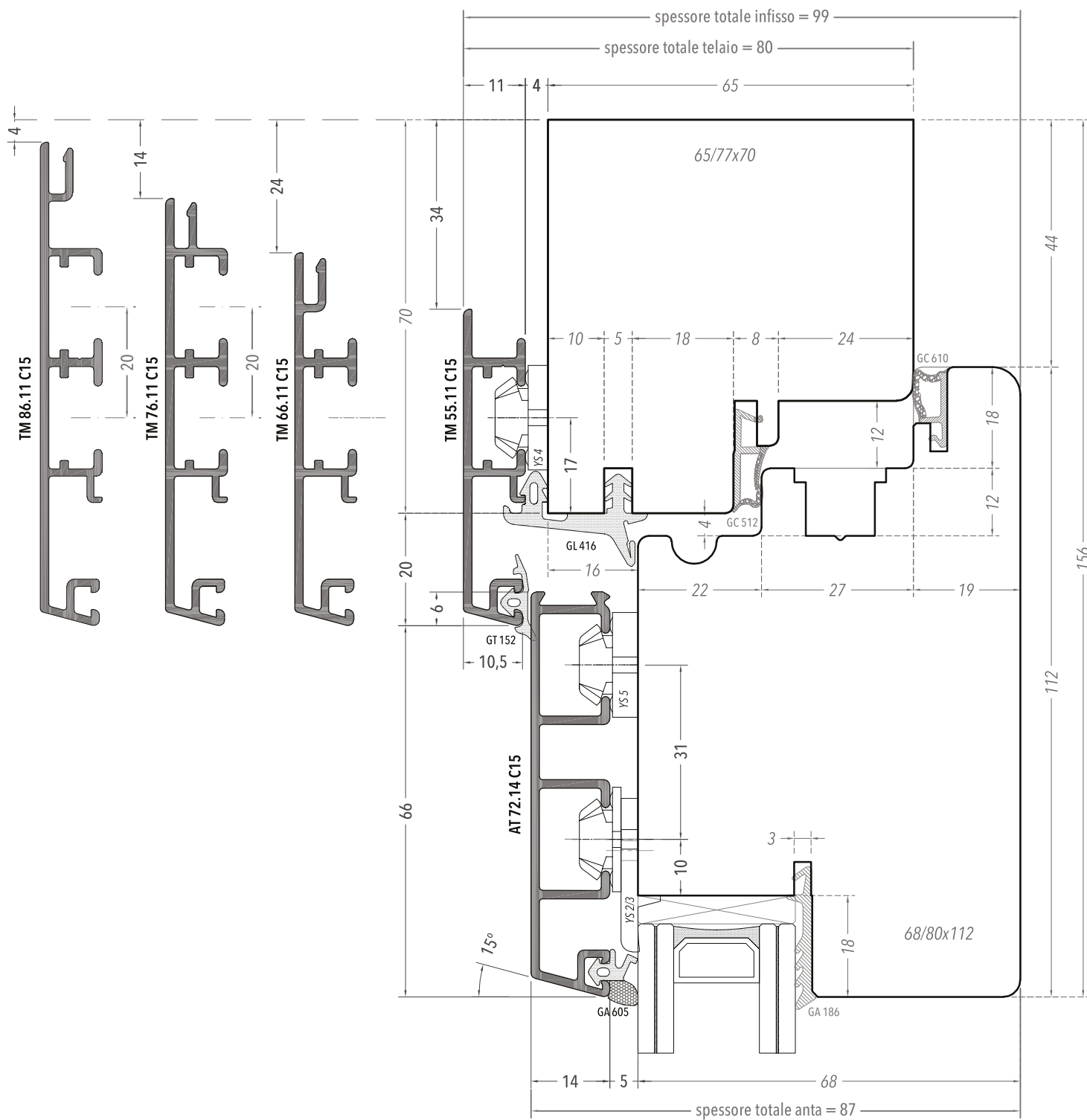

**PORTAFINESTRA CON SERRATURA PASSANTE**

SEZIONE ORIZZONTALE  
NODO LATERALE  
SCALA 1:1

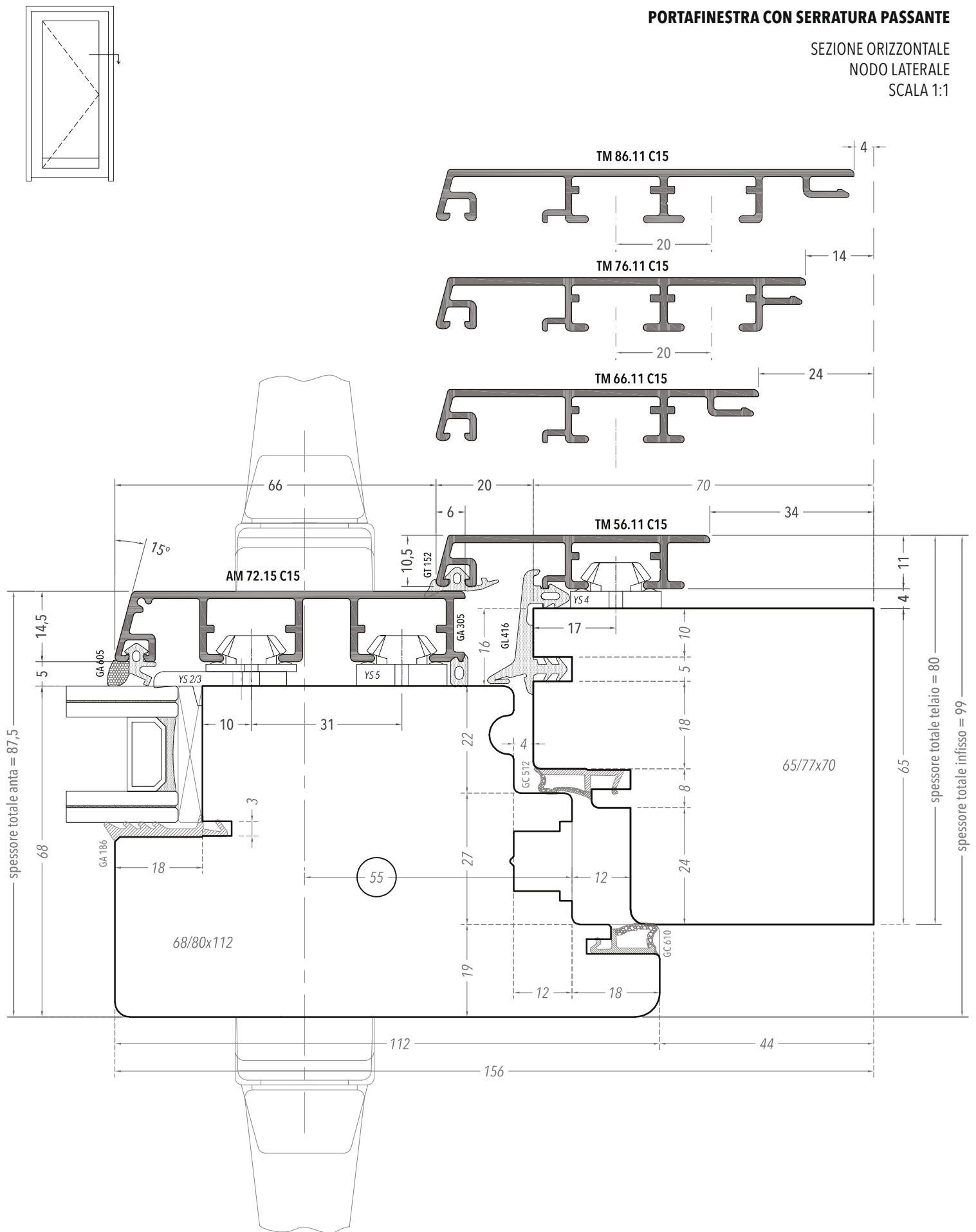

In caso di serratura passante, è possibile maggiorare solo il montante con la maniglia e lasciare invariata la sezione anta sugli altri lati.  
Entrata consigliata per la serratura: 55 mm.



Spessore telaio 68  
Spessore anta 68  
Per serramenti Euronorm

# Alumfast Sistema 21 Sistema 16

---

ABBINAMENTI

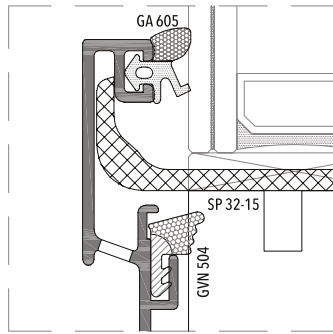
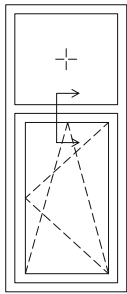

Variante con guarnizione  
GVN 504

**APRIBILE CON SOPRA-LUCE**

SEZIONE VERTICALE  
NODO ABBINAMENTO  
SCALA 1:1



Siliconatura dei listelli in legno

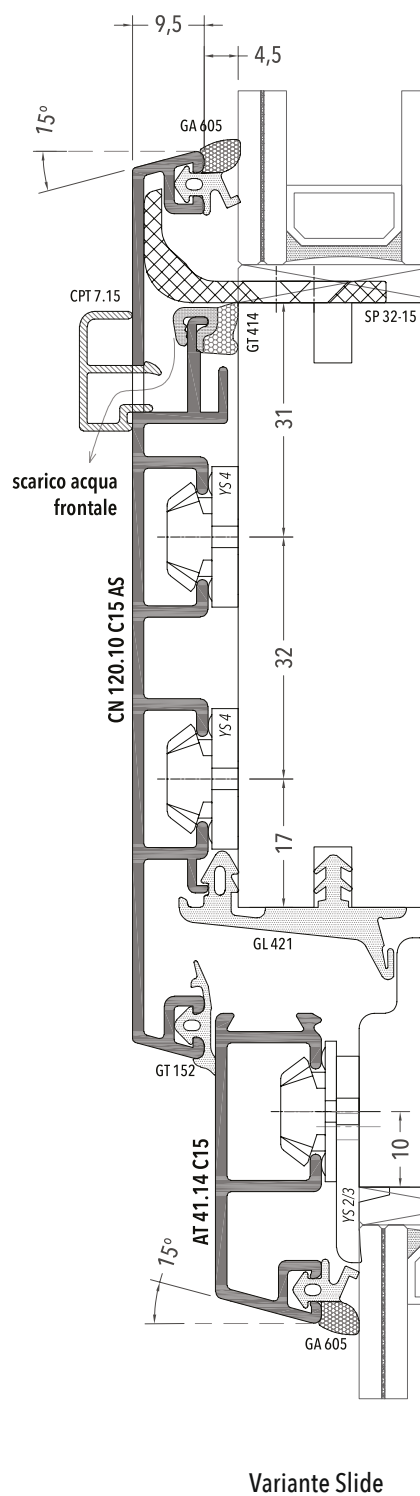

Variante Slide

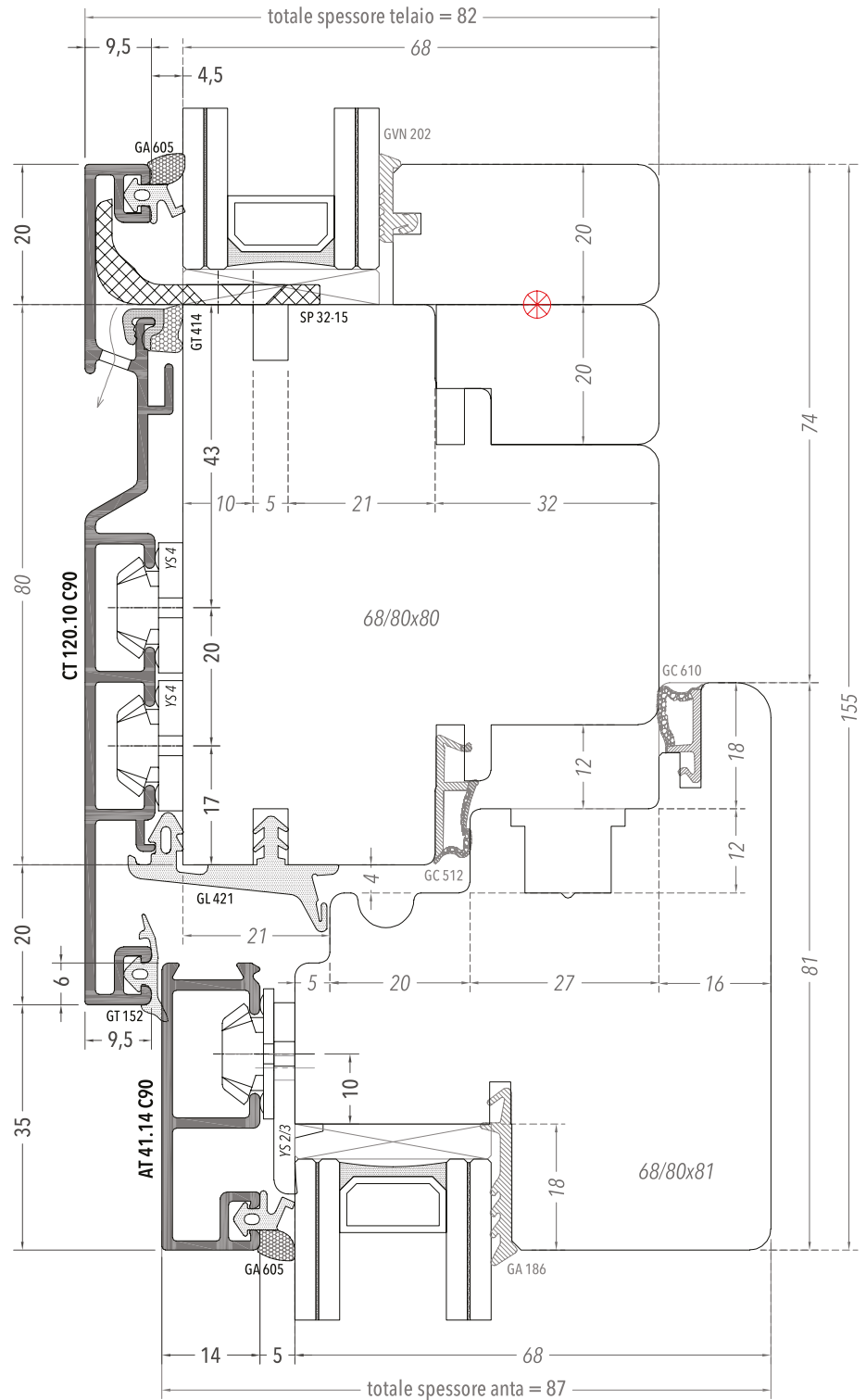

Soluzione valida anche per Sistema 16 con GL 416.



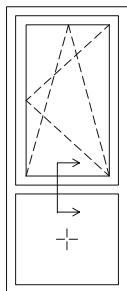

**APRIBILE CON SOTTO-LUCE**

SEZIONE VERTICALE  
NODO ABBINAMENTO  
SCALA 1:1

 Siliconatura dei listelli in legno

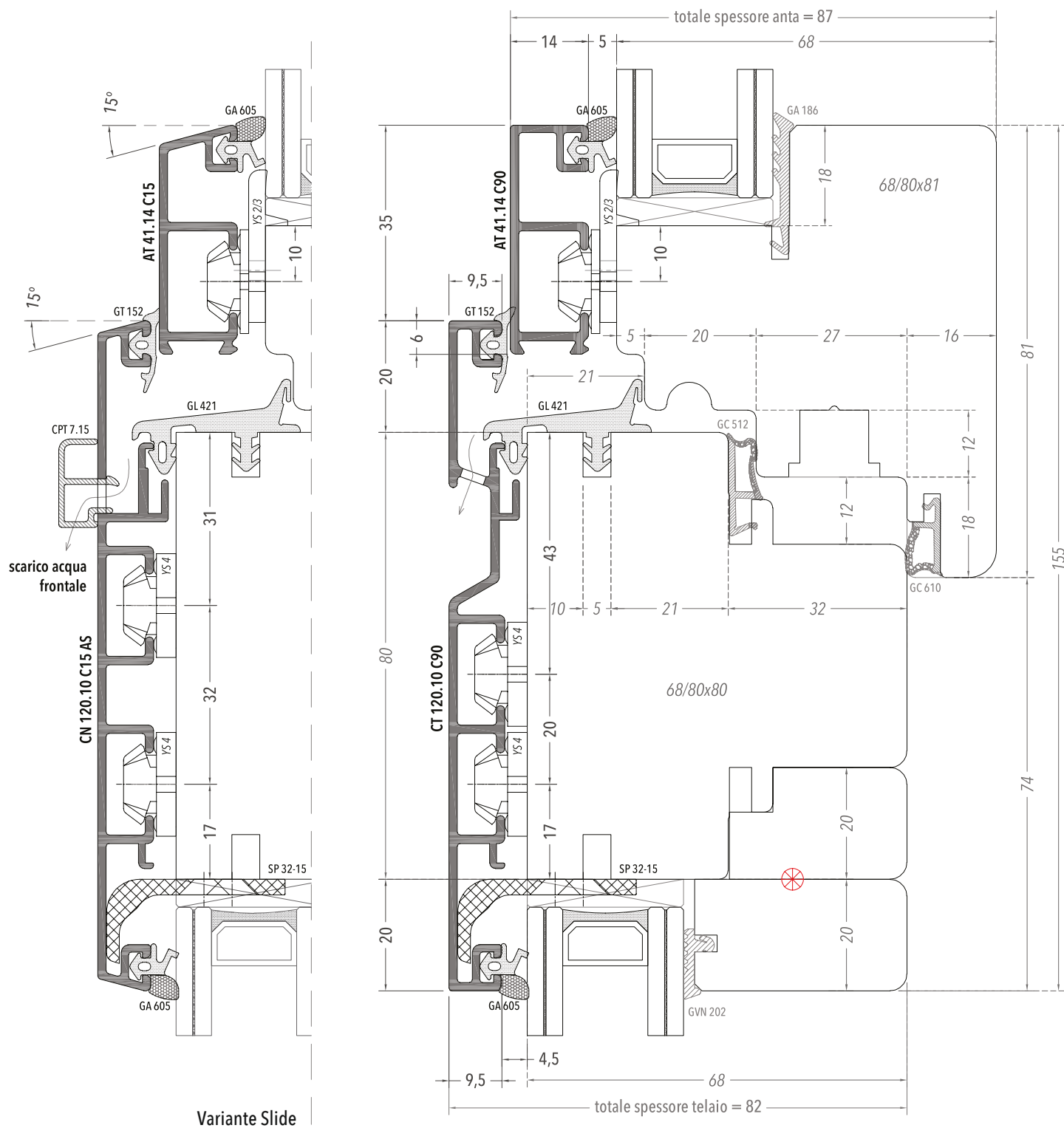

Soluzione valida anche per Sistema 16 con GL 416.

**FINESTRA CON SOPRA-LUCE APRIBILE**

SEZIONE VERTICALE  
NODO ABBINAMENTO  
SCALA 1:1

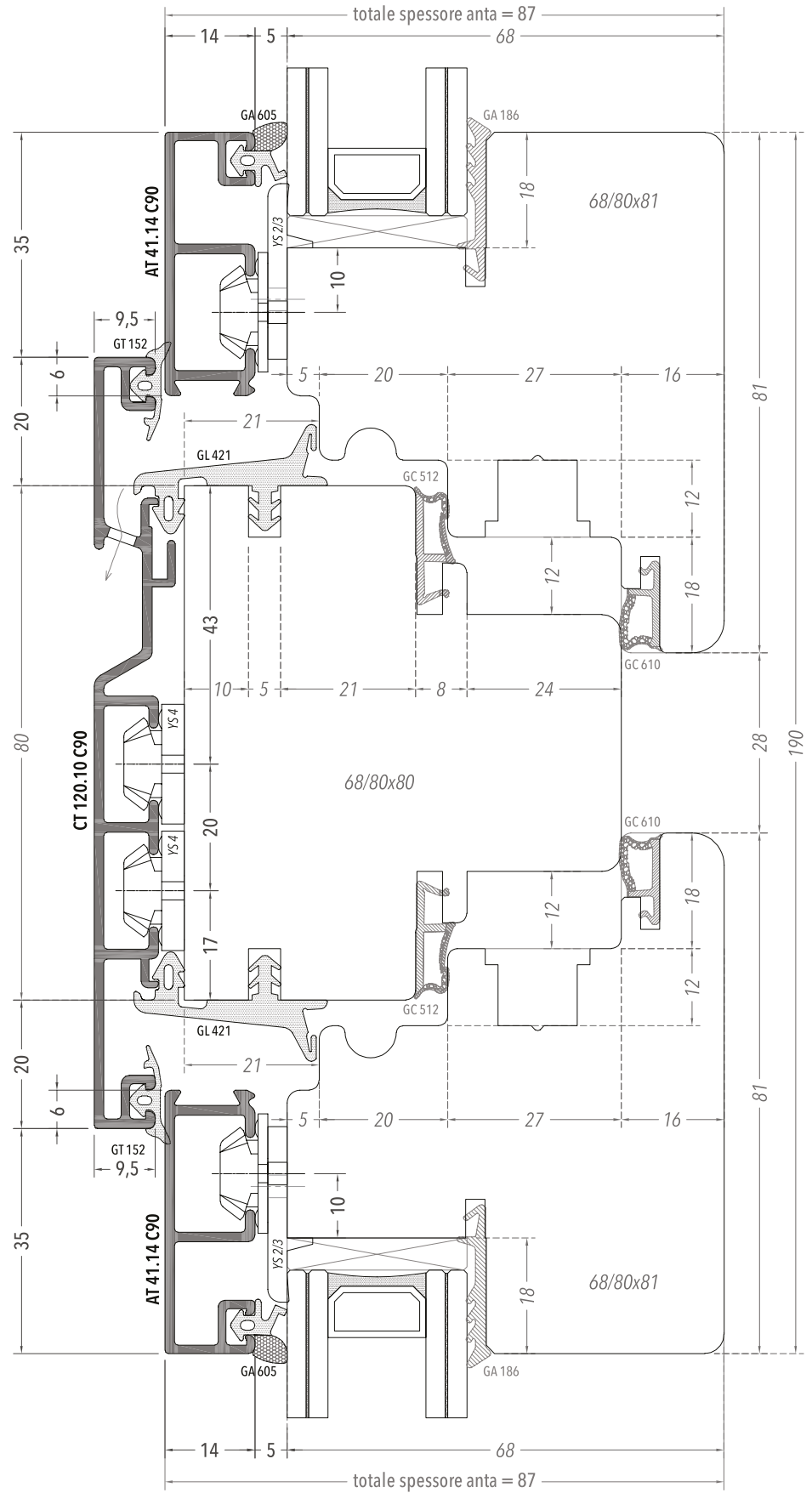
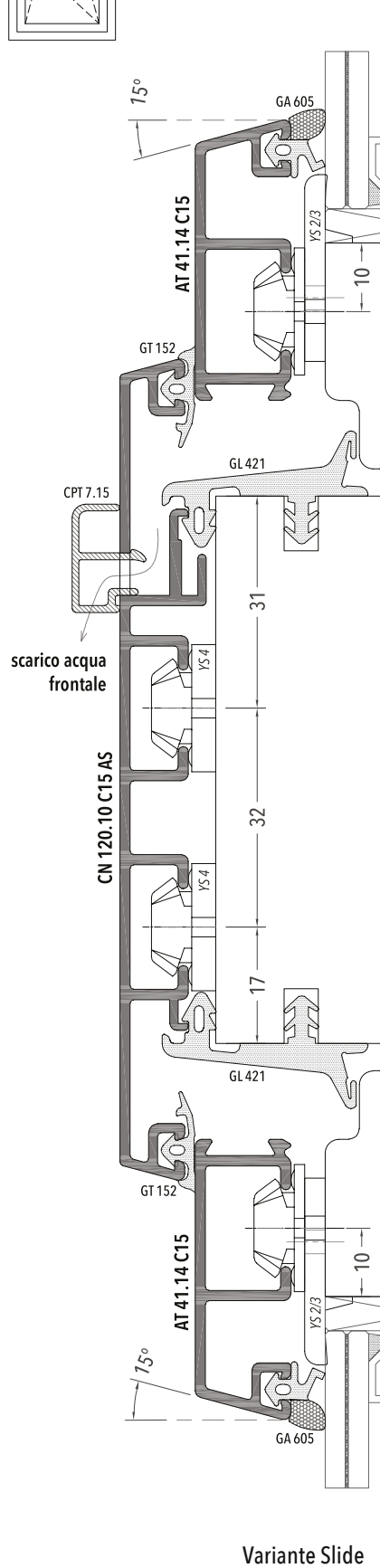
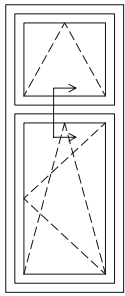

Soluzione valida anche per Sistema 16 con GL 416.

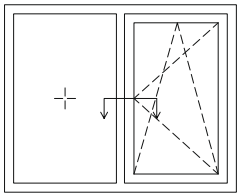

**FINESTRA CON FIANCO-LUCE**

SEZIONE ORIZZONTALE  
NODO ABBINAMENTO  
SCALA 1:1

Siliconatura dei listelli in legno

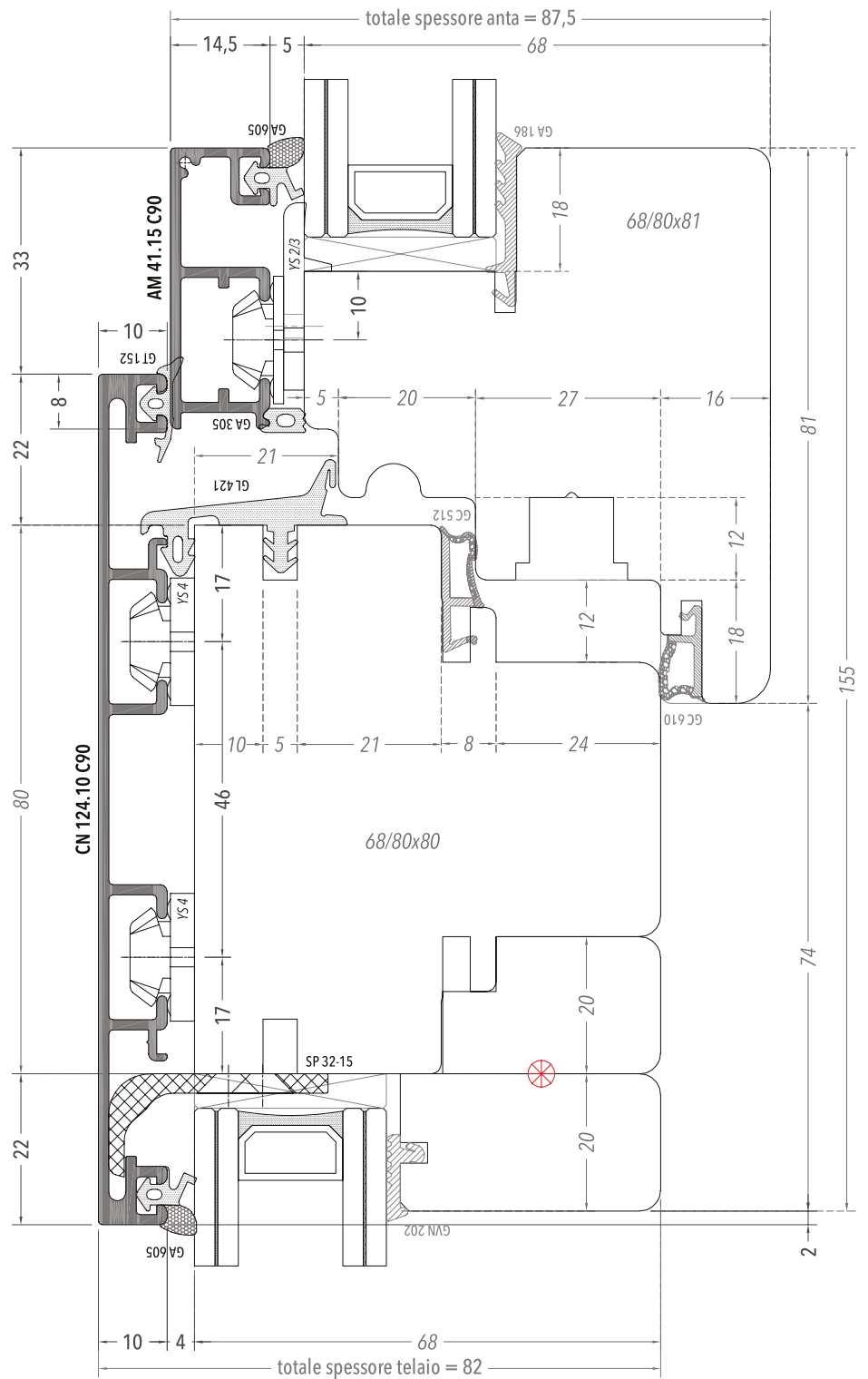
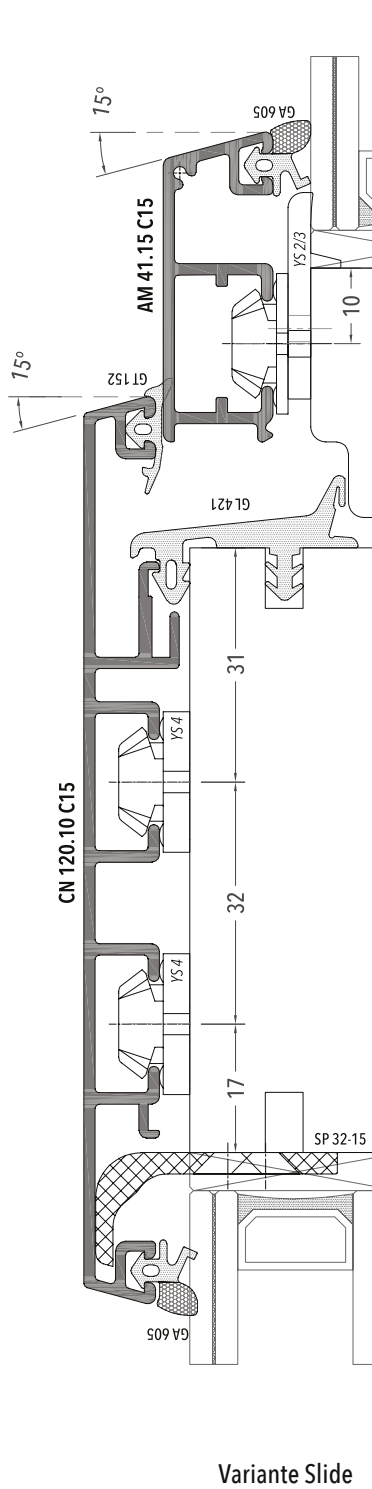



Soluzione valida anche per Sistema 16 con GL 416.

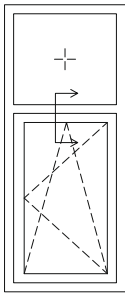

**APRIBILE CON SOPRA-LUCE**

SEZIONE VERTICALE  
NODO ABBINAMENTO  
SCALA 1:1



 Siliconatura dei listelli in legno

Alternare alla clip a scatto una basetta fermavetro auto-posizionante FV 2.2

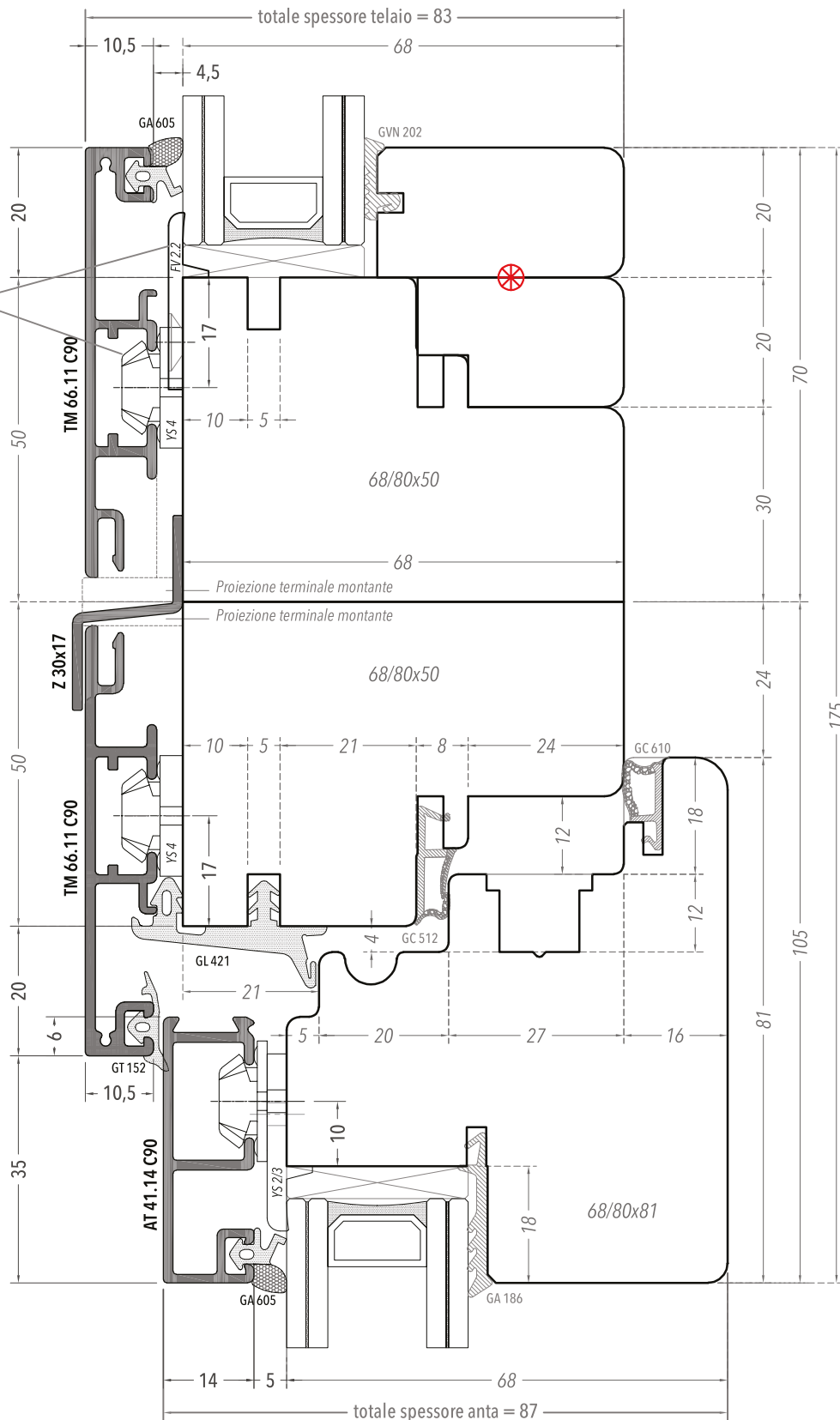

Il profilo Z3x17 verrà fornito con una lunghezza pari all'esterno telaio. Dovrà essere tagliato a misura luce interna montanti telaio in alluminio.

Soluzione valida anche per Sistema 16 con GL 416.  
Soluzione consigliata per abbinamenti di grandi dimensioni.

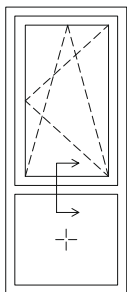

**APRIBILE CON SOTTO-LUCE**

SEZIONE VERTICALE  
NODO ABBINAMENTO  
SCALA 1:1

Siliconatura dei listelli in legno

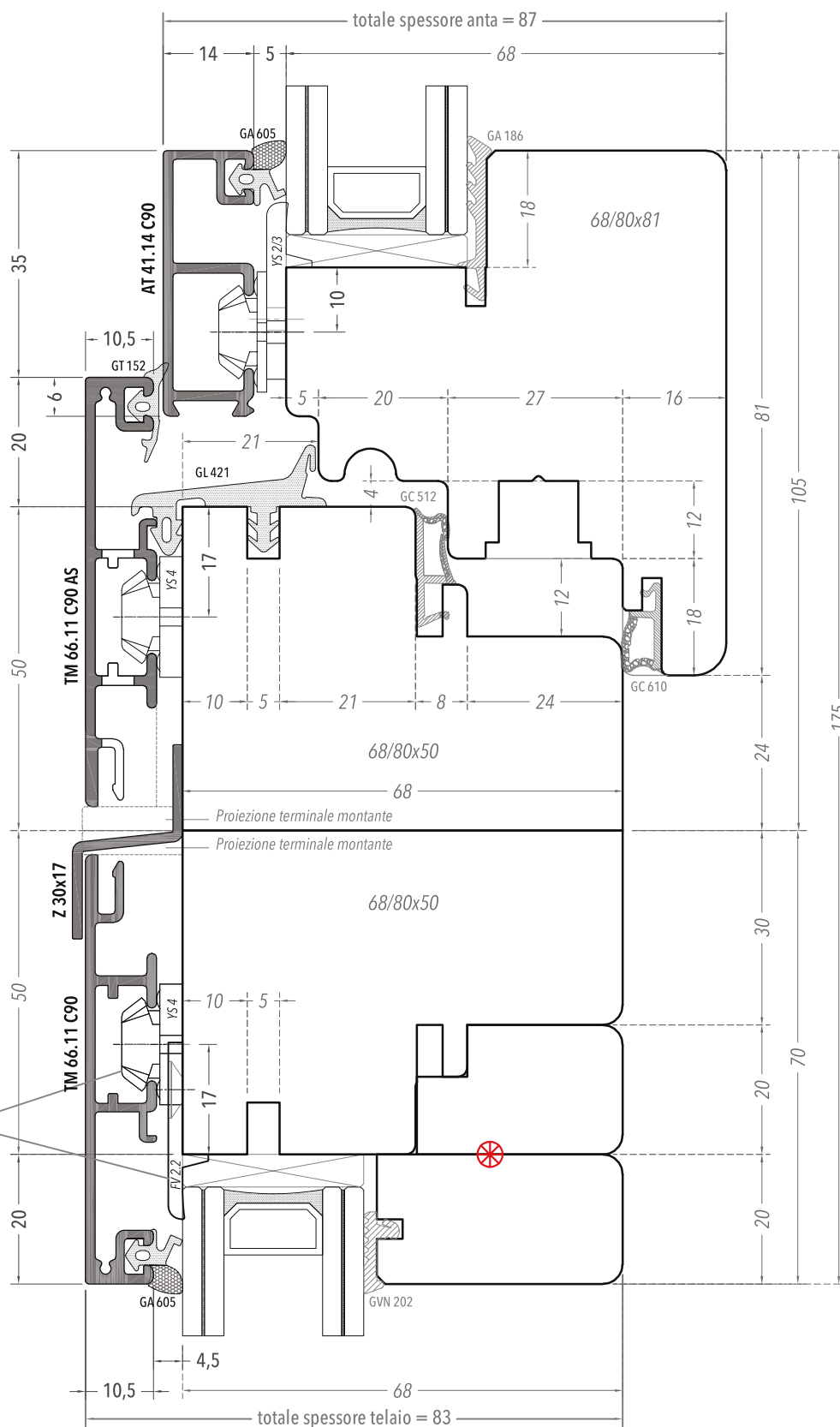

Alternare alla clip a scatto una basetta fermavetro auto-posizionante FV 2.2

Il profilo Z3x17 verrà fornito con una lunghezza pari all'esterno telaio. Dovrà essere tagliato a misura luce interna montanti telaio in alluminio.

Soluzione valida anche per Sistema 16 con GL 416.  
Soluzione consigliata per abbinamenti di grandi dimensioni.

**FINESTRA CON SOPRA-LUCE APRIBILE**

SEZIONE VERTICALE  
NODO ABBINAMENTO  
SCALA 1:1

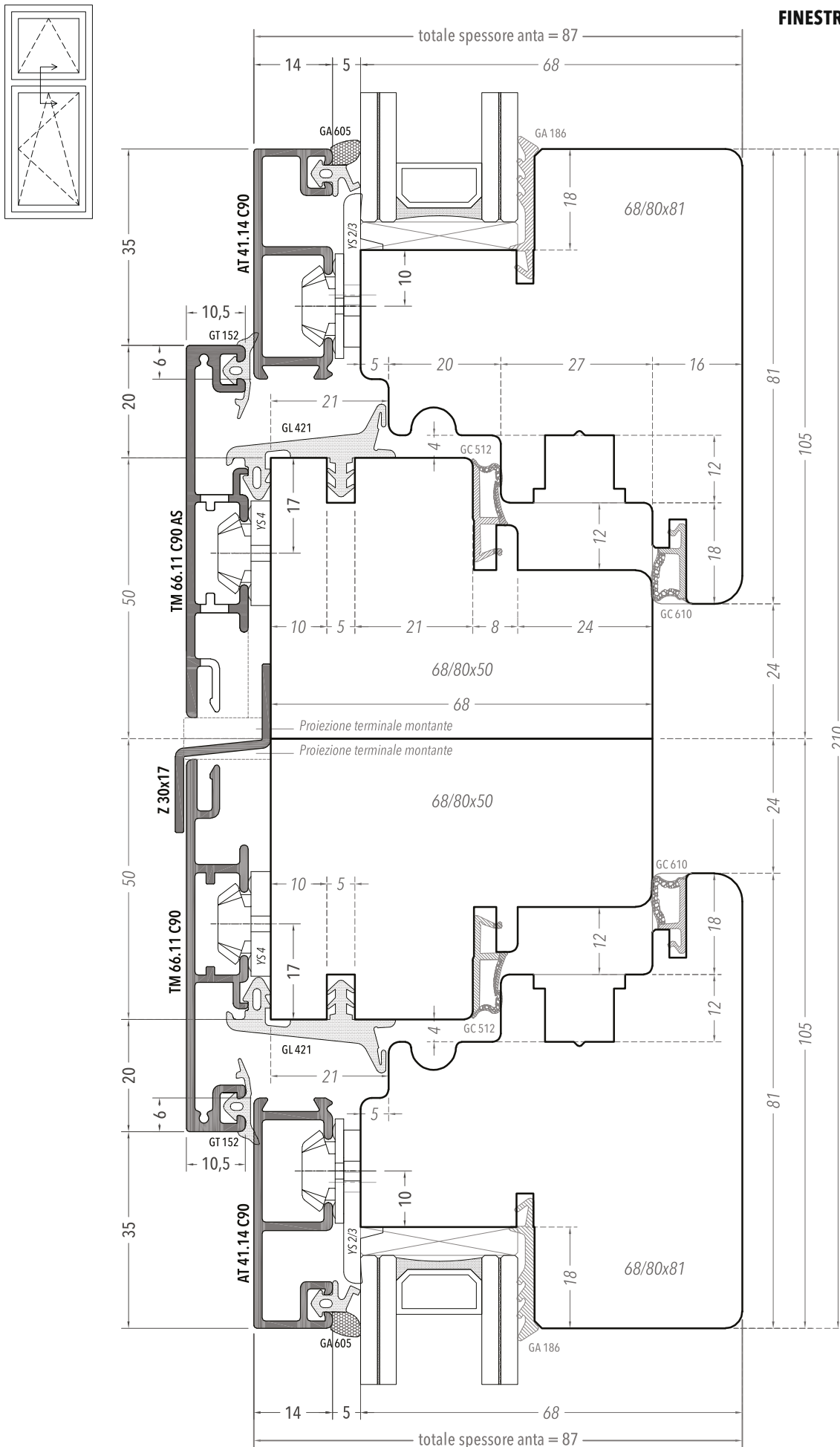

Soluzione valida anche per Sistema 16 con GL 416.  
Soluzione consigliata per abbinamenti di grandi dimensioni.

Il profilo Z3x17  
verrà fornito con  
una lunghezza pari  
all'esterno telaio. Dovrà  
essere tagliato a misura  
luce interna montanti  
telaio in alluminio.

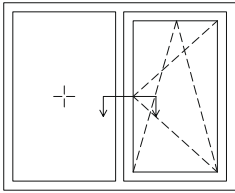

## FINESTRA CON FIANCO-LUCE

SEZIONE ORIZZONTALE  
NODO ABBINAMENTO  
SCALA 1:1

 Siliconatura dei listelli in legno

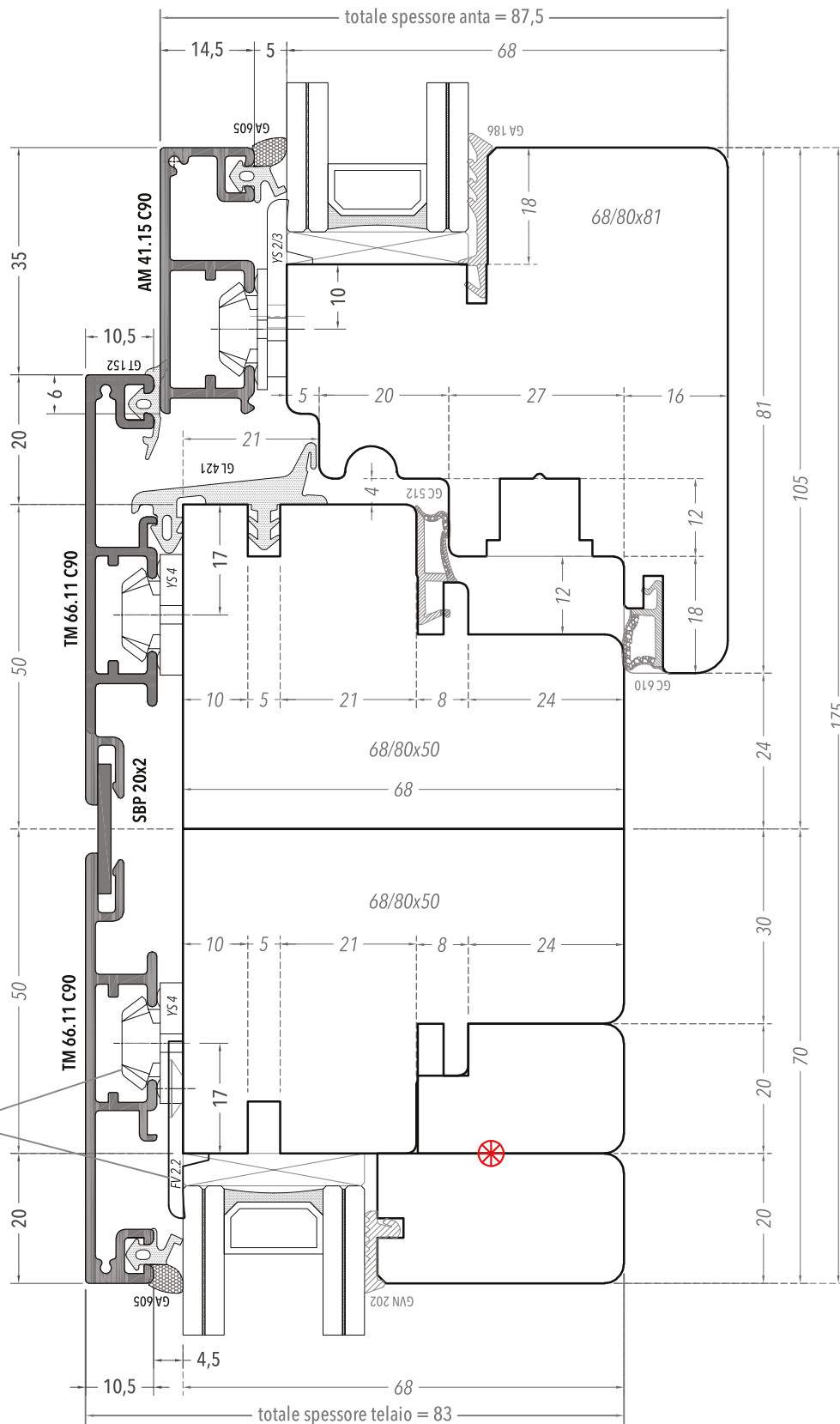

Alternare alla clip a scatto una basetta fermavetro auto-posizionante FV 2.2

Il profilo Z3x17 verrà fornito con una lunghezza pari all'esterno telaio. Dovrà essere tagliato a misura luce interna montanti telaio in alluminio.

Soluzione valida anche per Sistema 16 con GL 416.  
Soluzione consigliata per abbinamenti di grandi dimensioni.







# Alumfast Sistema 21 Sistema 16

---

FISSI, TRAVERSI,  
INGLESINE

## TELAIO FISSO

Soluzione valida per Sistema 21 e Sistema 16.  
Scelta consigliata in caso di abbinamenti  
(sopra-luce, fianco-luce, ecc.).

I profili Standard sono totalmente intercambiabili  
con i profili Slide.

- ⊗ Basetta fermavetro auto-posizionante FV 2.2  
alternata alla clip a scatto (YS 4 o YS 5).
- ⊗ Siliconatura dei listelli in legno.

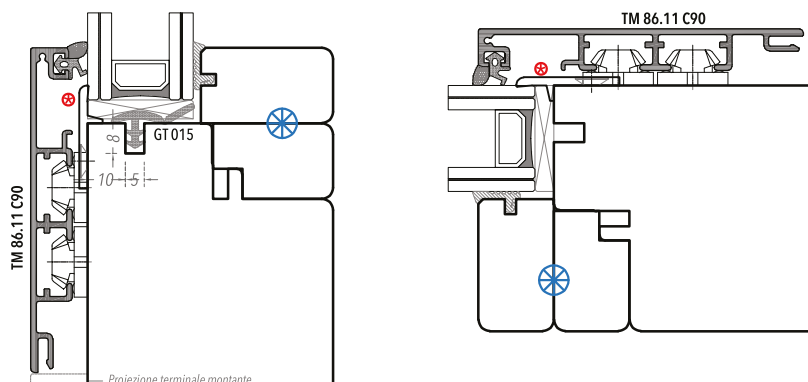

## SOLUZIONI PER SERRAMENTO FISSO

## QUADROTTO CON FERMAVETRO RIPORTATO

Soluzione valida per tutti i sistemi.

I profili Standard sono totalmente intercambiabili  
con i profili Slide.

- ⊗ Basetta fermavetro auto-posizionante FV 2.2  
alternata alla clip a scatto (YS 4 o YS 5).
- ⊗ Siliconatura dei listelli in legno.

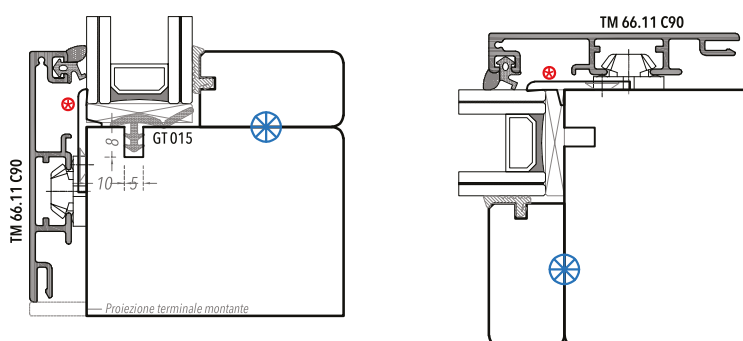

## SOLUZIONI PER SERRAMENTO FISSO

## PROFILO ANTA (CON FERMAVETRO INTEGRATO)

Soluzione valida per tutti i sistemi.

Il vetro è fissato dall'esterno con basette  
auto-posizionanti FV ⊗ alternate alle clip a scatto  
(YS 4 o YS 5).

I profili Standard sono totalmente intercambiabili  
con i profili Slide.

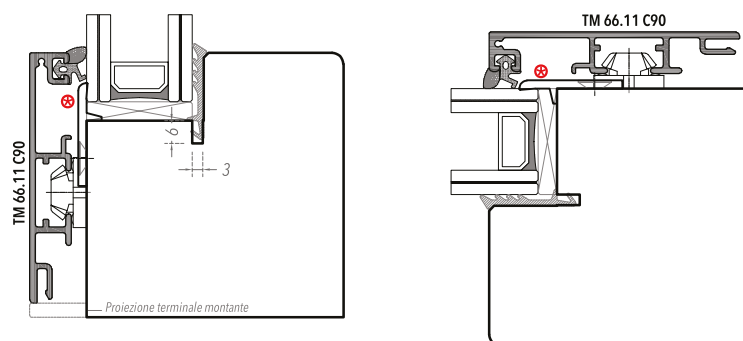

Le dimensioni del nodo dipendono dal tipo di profilo che si intende utilizzare. Possono essere applicati tutti i profili telaio illustrati delle pagine precedenti.

⊗ Basetta fermavetro auto-posizionante FV 2.2 alternata alla clip a scatto (YS 4 o YS 5).

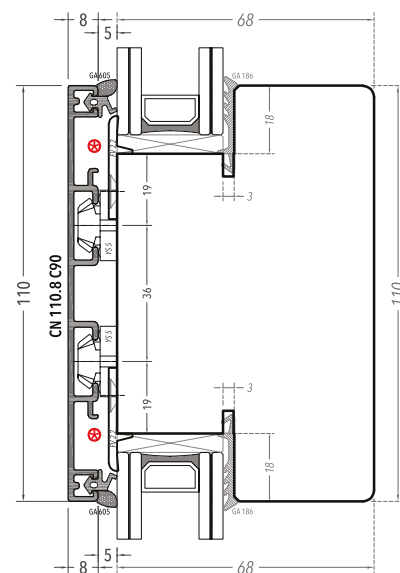
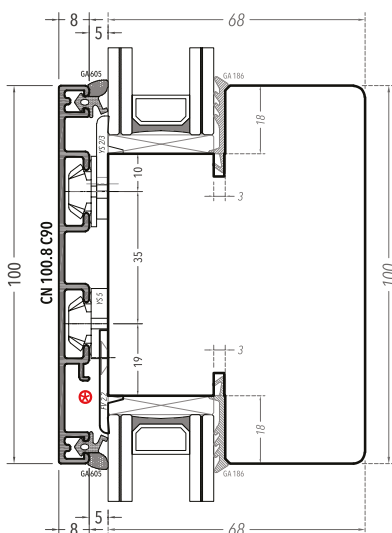
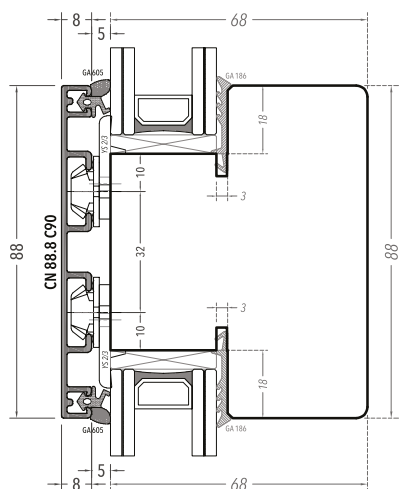
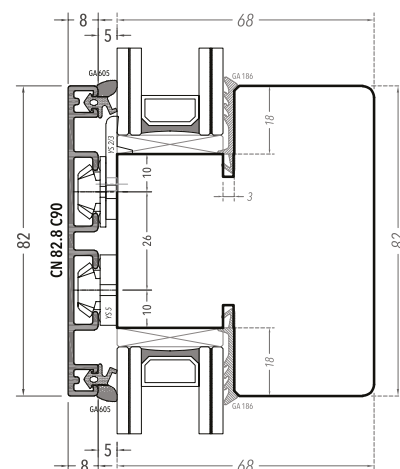
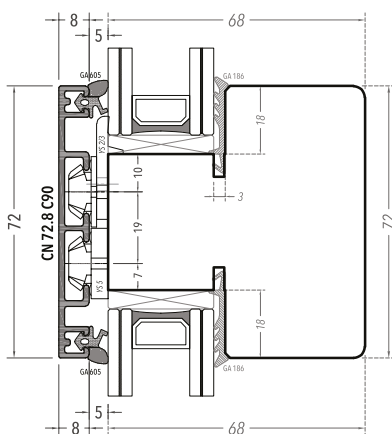
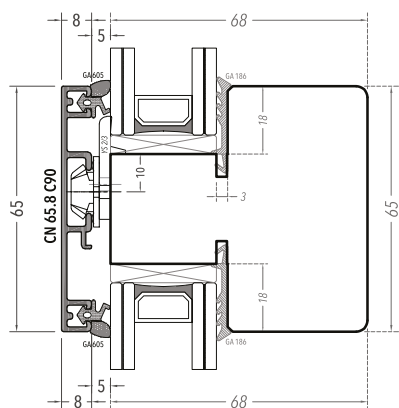

SOLUZIONI PER INGLESINE

Fissaggio inglesina con staffe di testa agganciate ai montanti

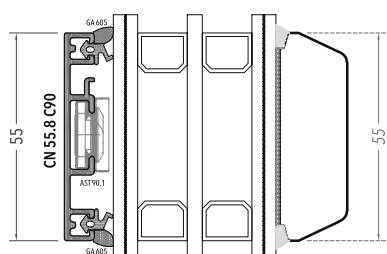



Spessore telaio 65  
Spessore anta 68  
Per serramenti Freumex

# Alumfast Sistema 16 Eco

---

STANDARD

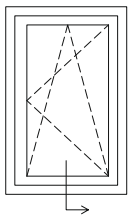

**FINESTRA**

SEZIONE VERTICALE  
NODO INFERIORE  
SCALA 1:1

Variante traverso  
inferiore con profilo  
Slide inclinato a 15°

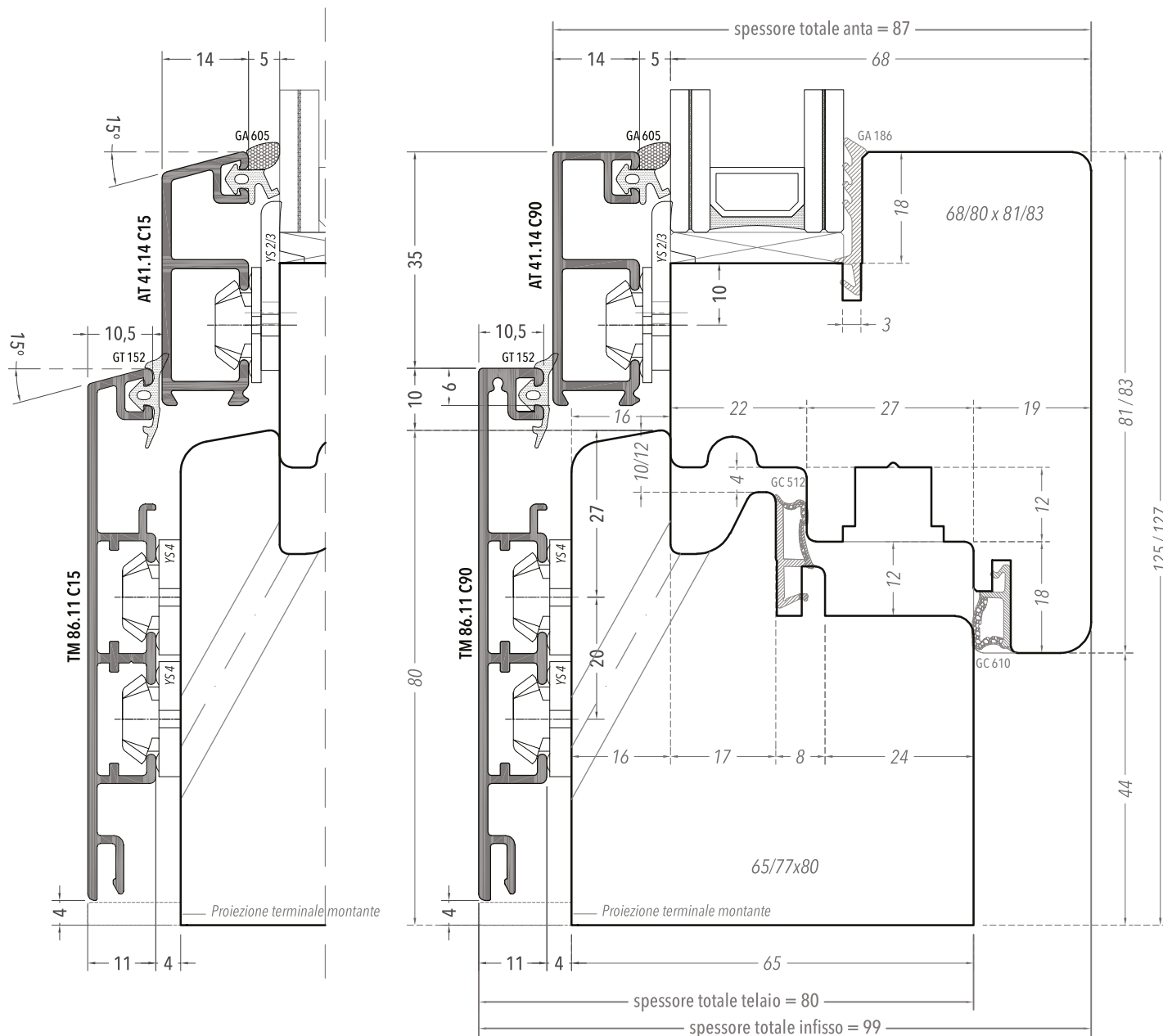

In caso di serramenti in legno-alluminio è sconsigliata l'applicazione della guarnizione GC604.



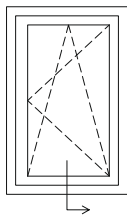

Variante traverso inferiore con profilo Slide inclinato a 15°

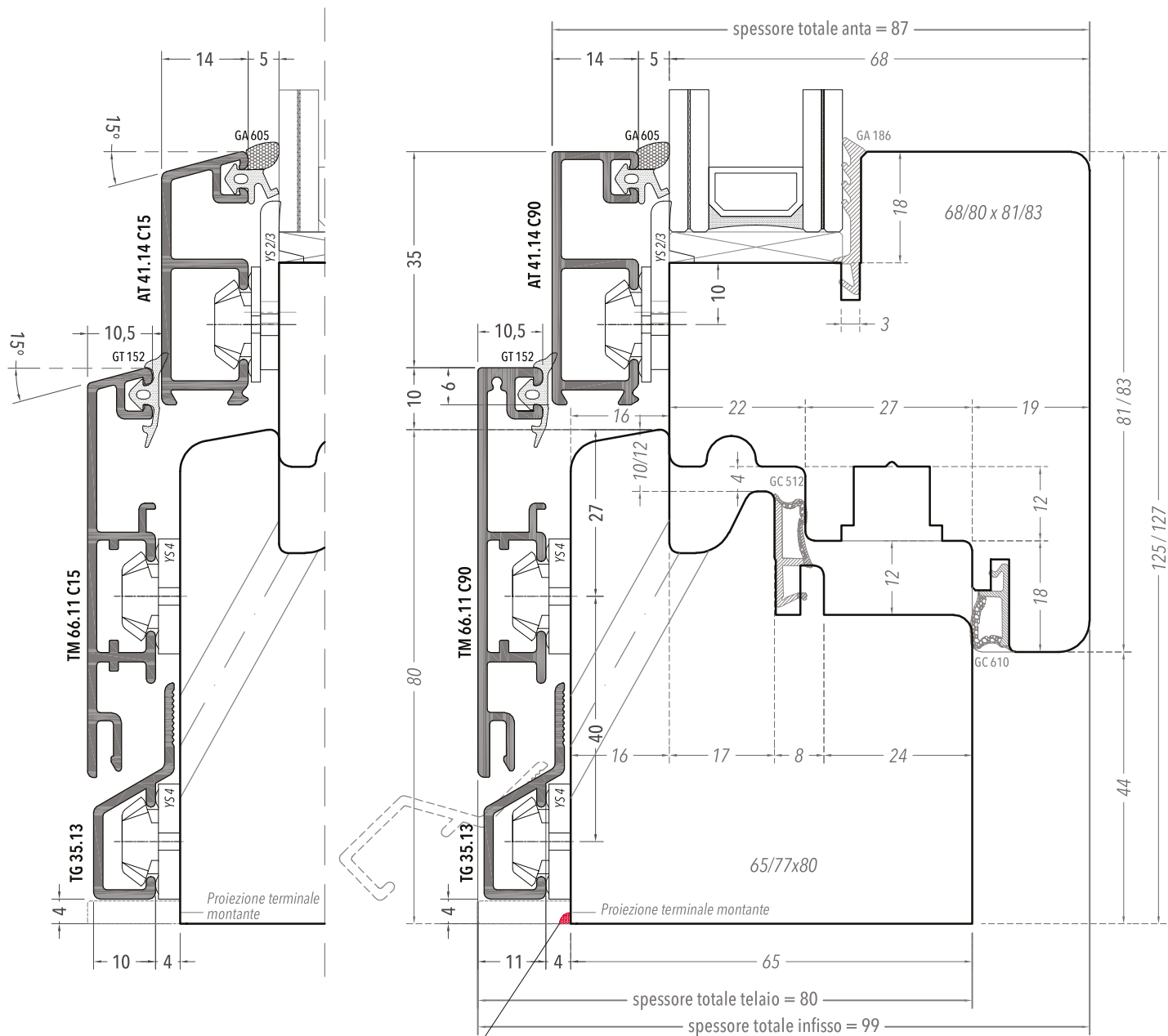

Agganciare il TG 35.13 su clip a scatto dopo aver silconato

Variante con profilo gocciolatoio (tagliato in luce ai montanti del telaio).  
In caso di serramenti in legno-alluminio è sconsigliata l'applicazione della guarnizione GC604.

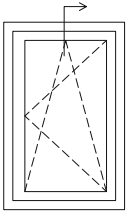

**FINESTRA**

SEZIONE VERTICALE  
NODO SUPERIORE  
SCALA 1:1

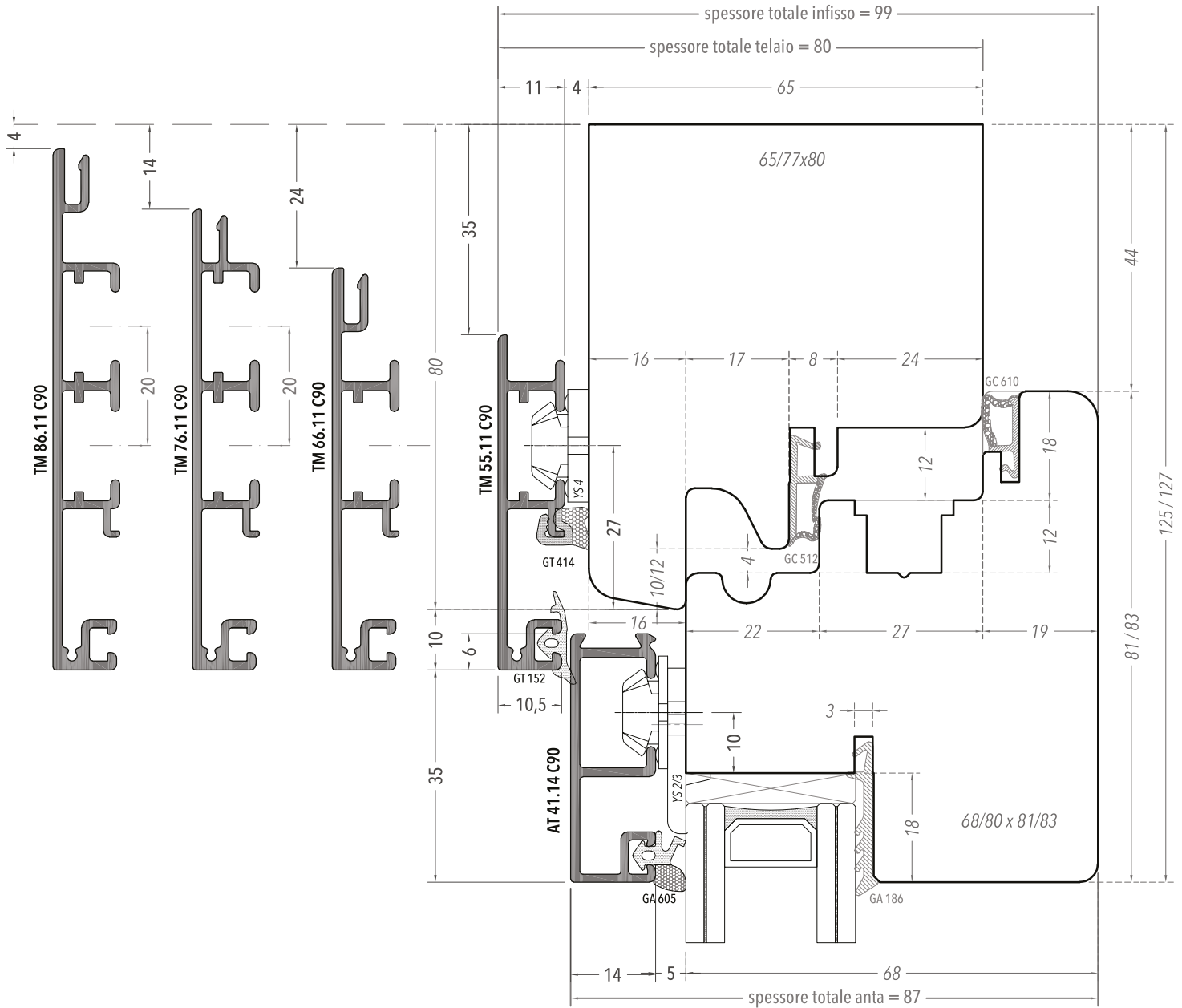

In caso di serramenti in legno-alluminio è sconsigliata l'applicazione della guarnizione GC604.

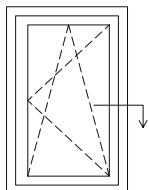

**FINESTRA**

SEZIONE ORIZZONTALE  
 NODO LATERALE  
 SCALA 1:1

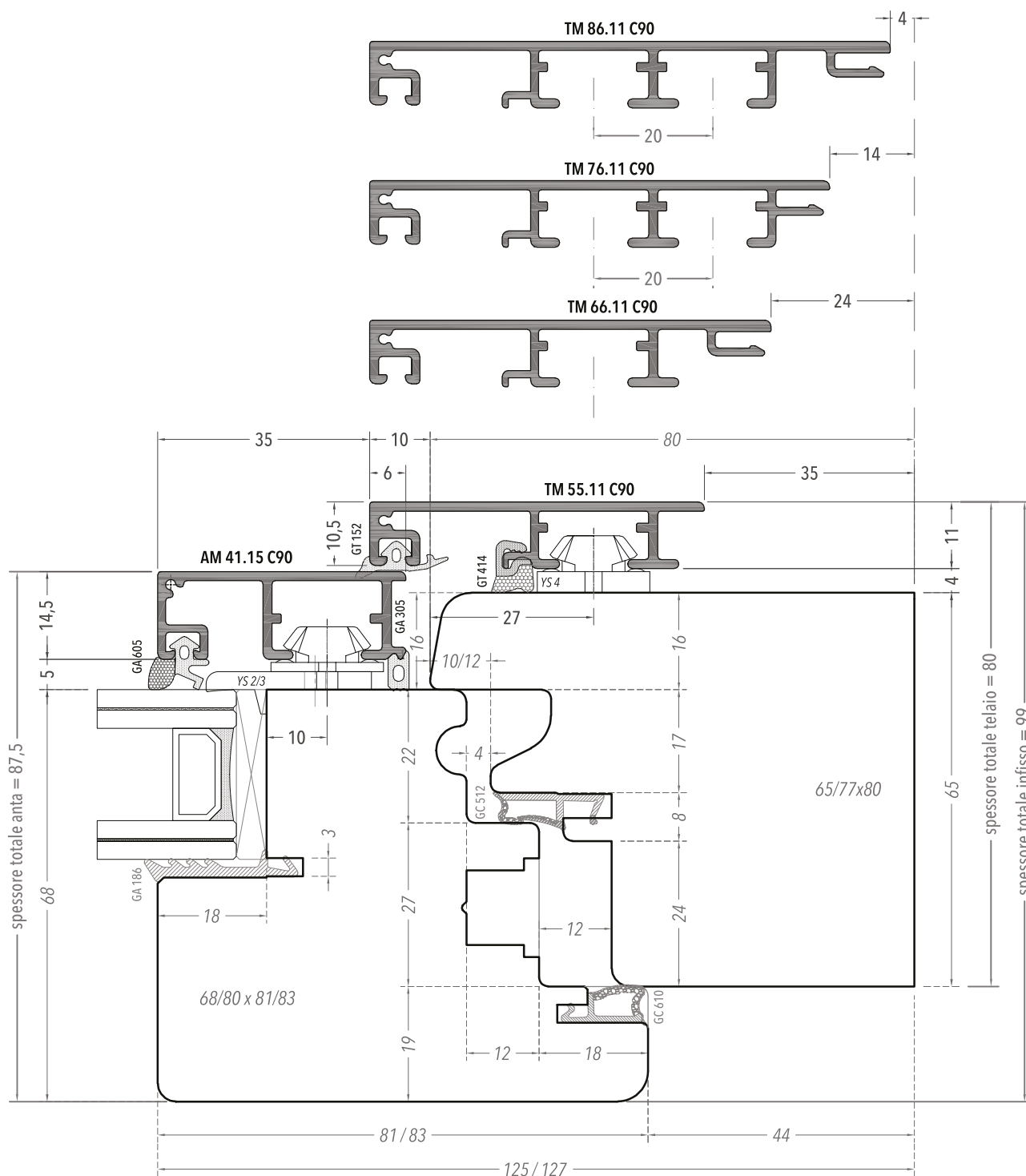

In caso di serramenti in legno-alluminio è sconsigliata l'applicazione della guarnizione GC604.

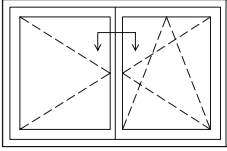

**FINESTRA**

SEZIONE ORIZZONTALE  
 NODO CENTRALE  
 SCALA 1:1

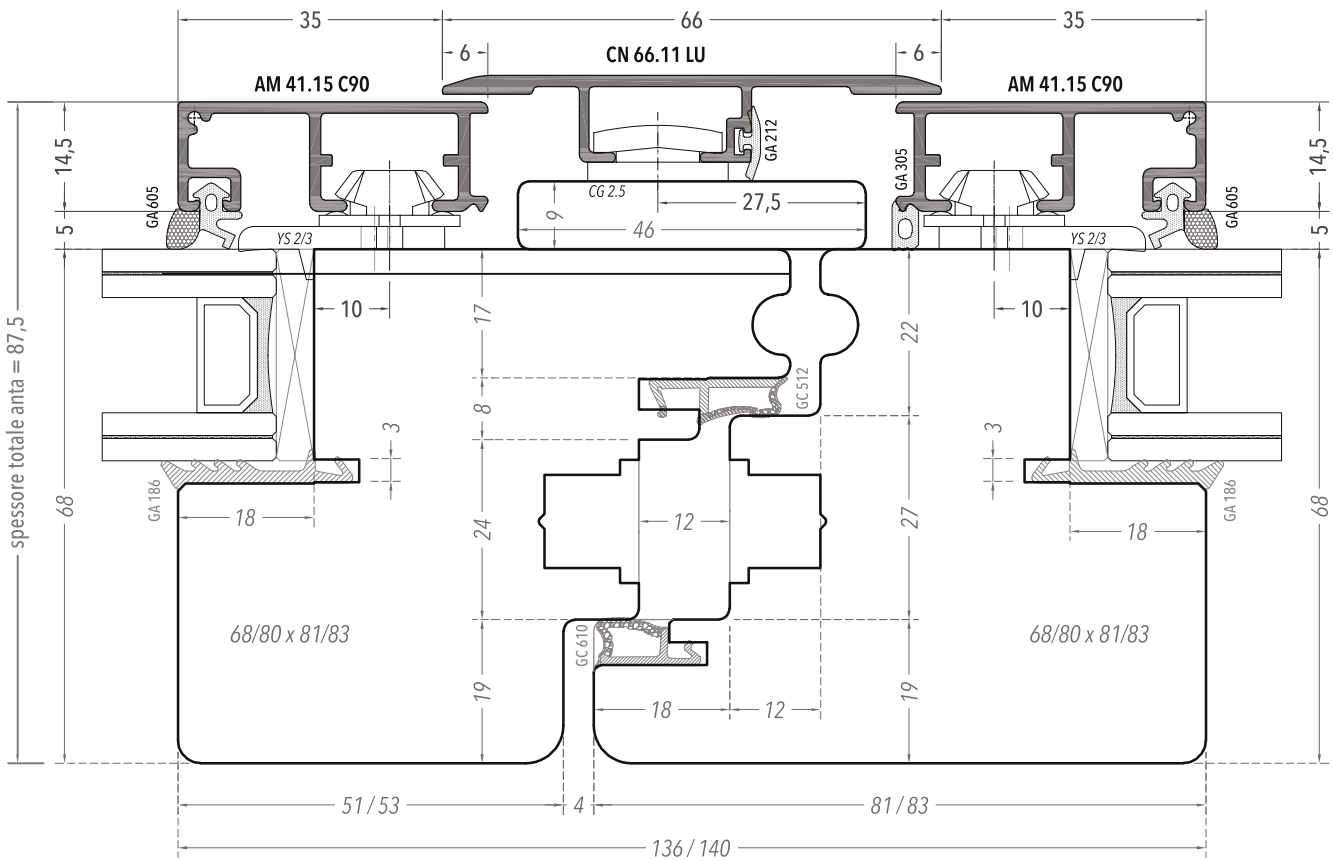
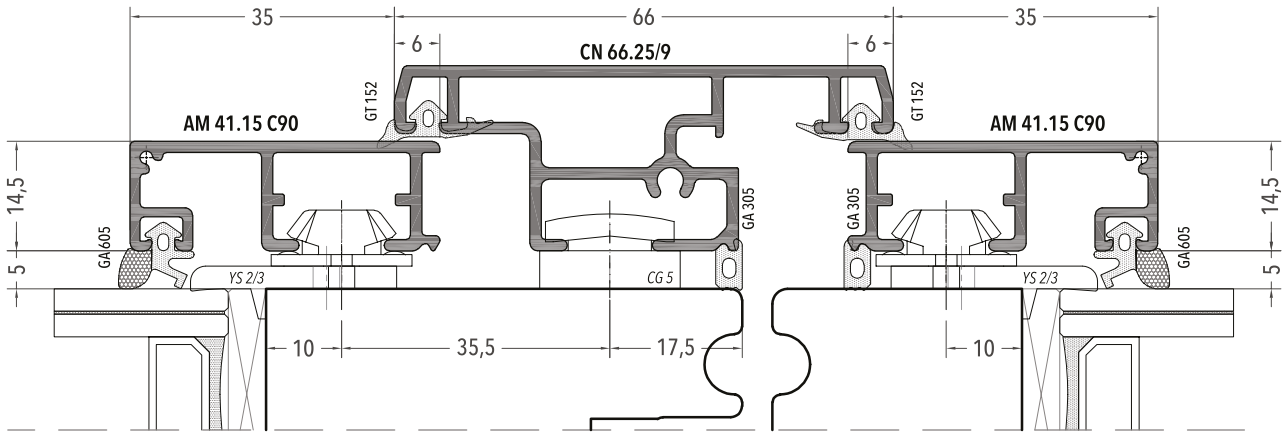

Per il disegno del nodo con montantino aggiunto, consulta la pagina del montantino Sistema 21 Standard.

**PORTAFINESTRA**

SEZIONE VERTICALE  
NODO INFERIORE  
SCALA 1:1

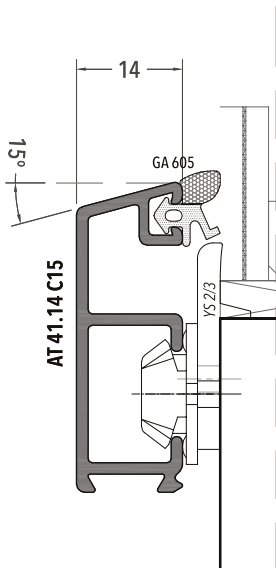
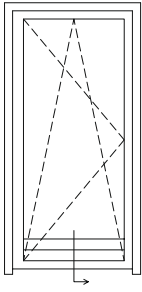

Variante con profilo  
inclinato a 15°  
su trav. inferiore anta

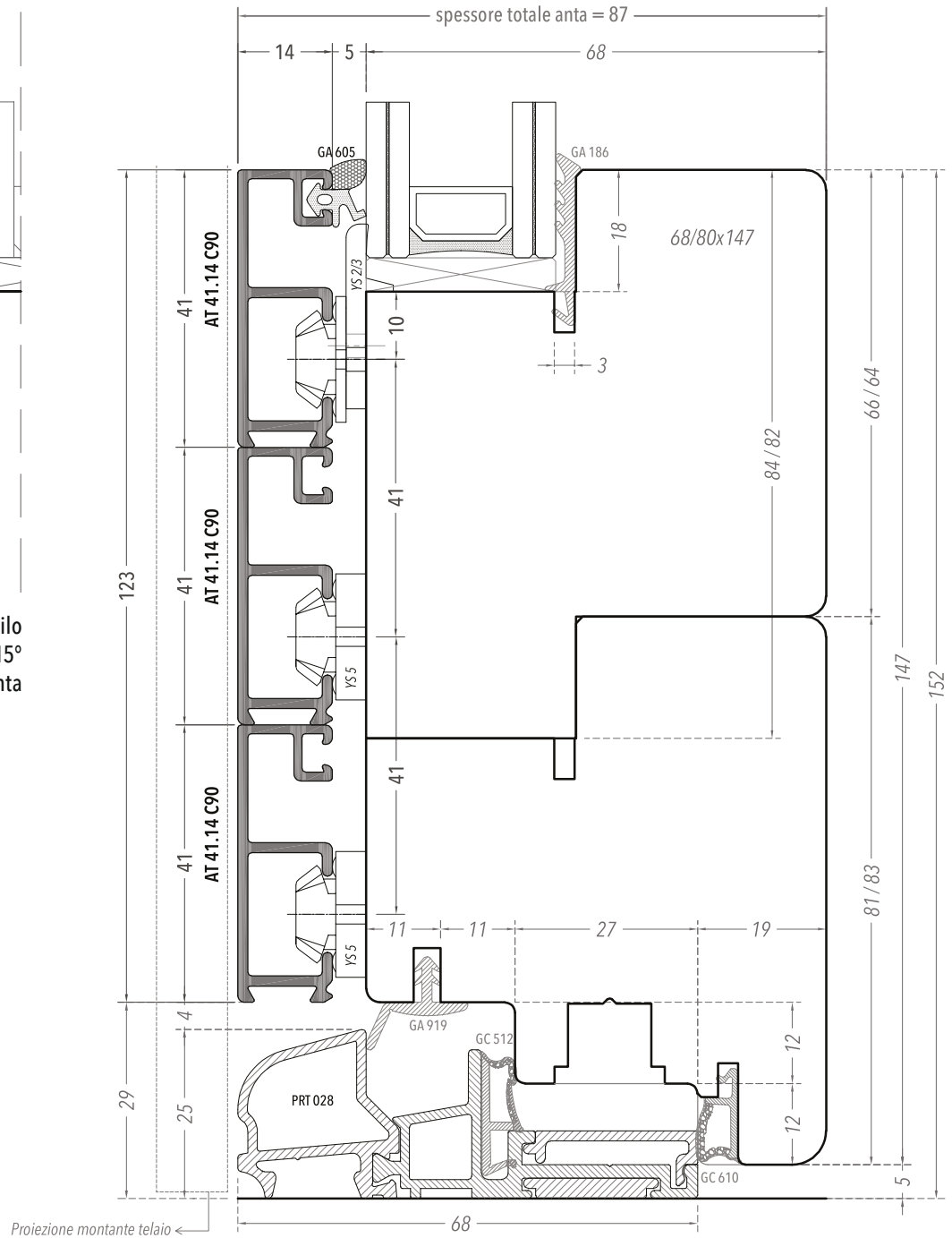

Per tutte le altre combinazioni di profili per gli zoccoli della portafinestra, consulta le pagine introduttive del catalogo.

**PORTAFINESTRA CON SERRATURA PASSANTE**

SEZIONE VERTICALE  
NODO SUPERIORE  
SCALA 1:1

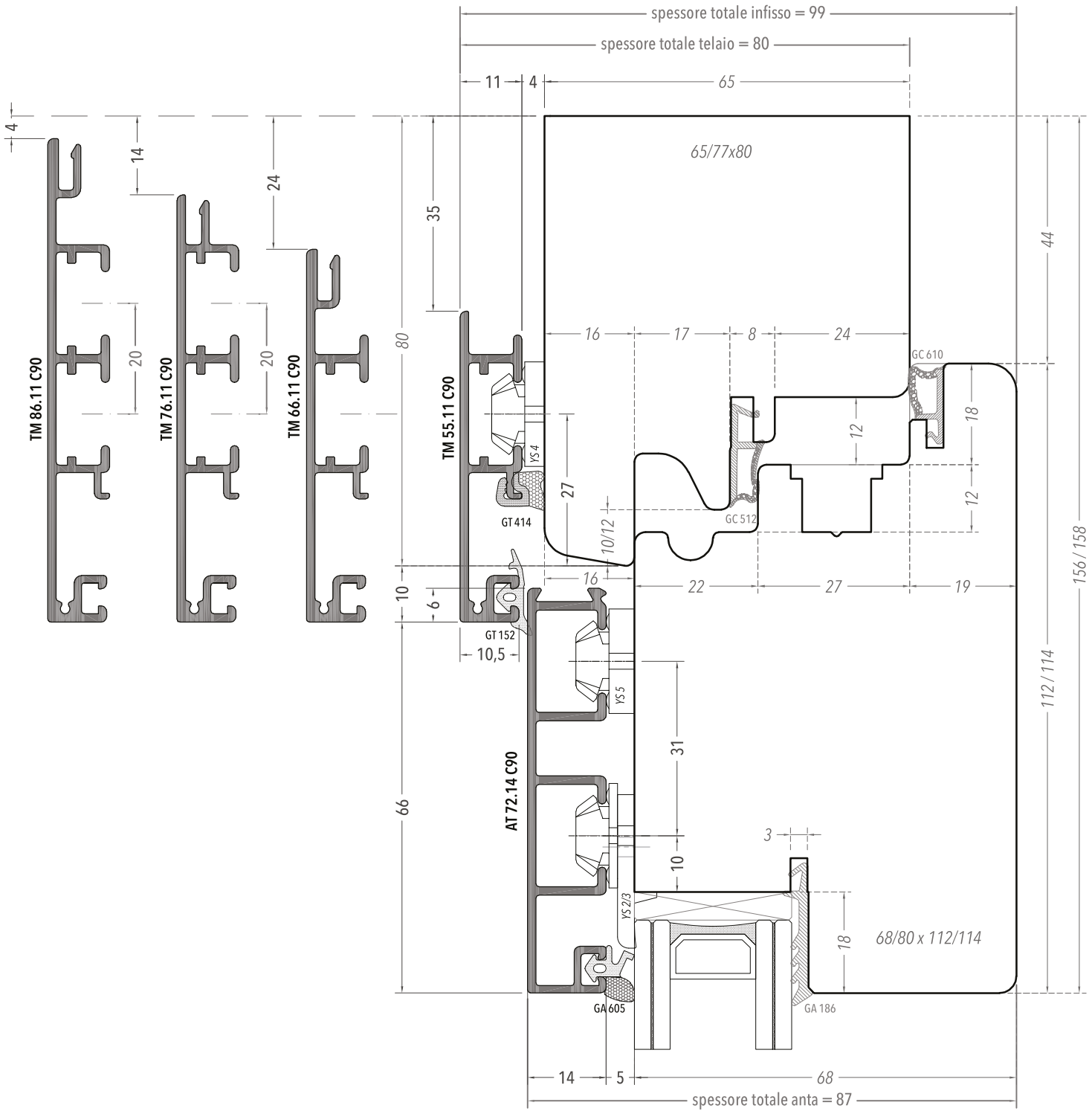
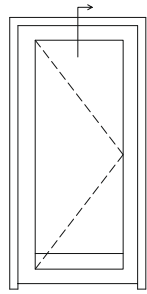

In caso di serramenti in legno-alluminio è sconsigliata l'applicazione della guarnizione GC604.

PORTAFINESTRA CON SERRATURA PASSANTE

SEZIONE ORIZZONTALE  
NODO LATERALE  
SCALA 1:1

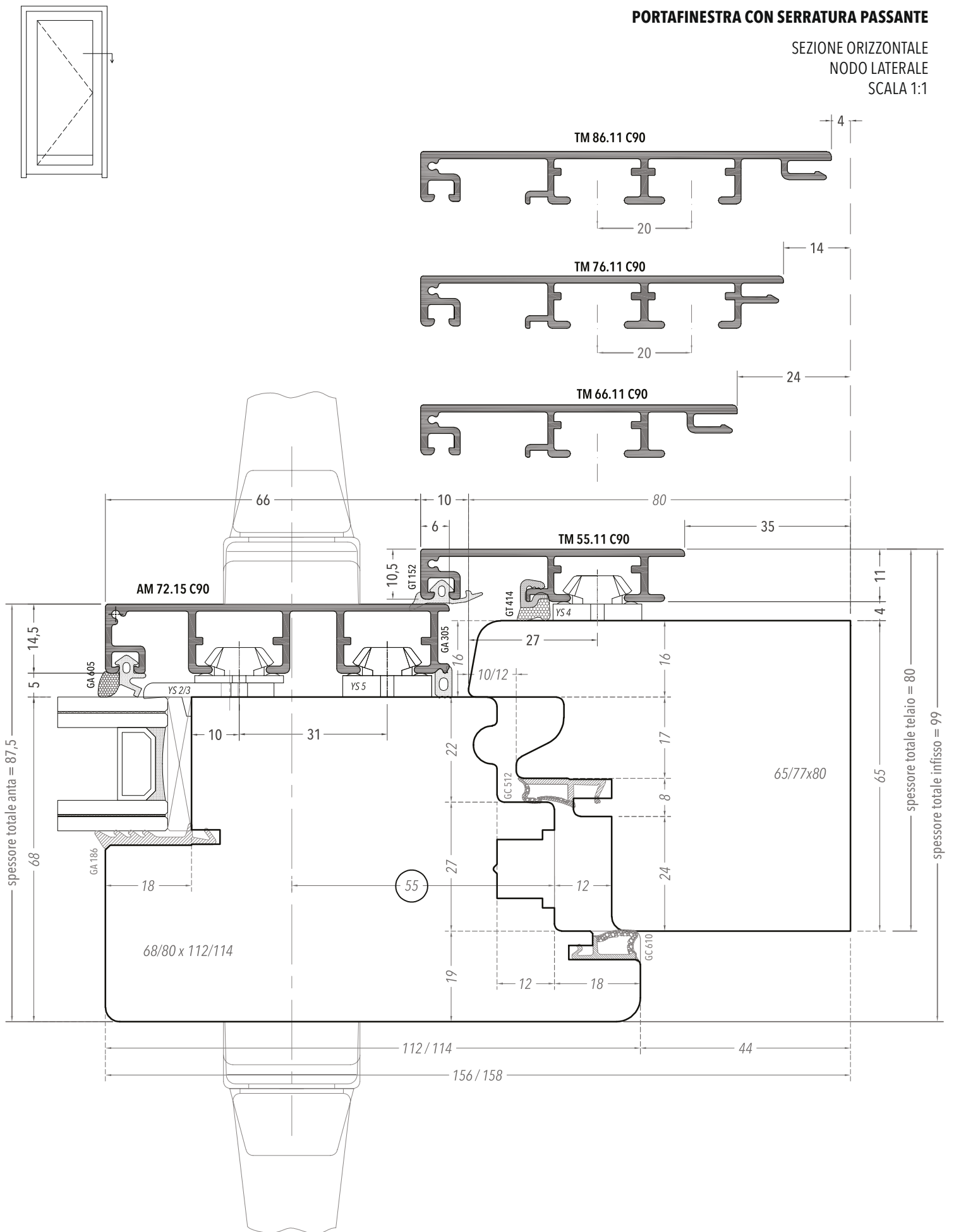

In caso di serratura passante, è possibile maggiorare solo il montante con la maniglia e lasciare invariata la sezione anta sugli altri lati.  
Entrata consigliata per la serratura: 55 mm.

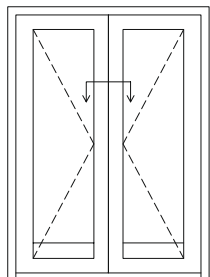

**PORTAFINESTRA CON SERRATURA PASSANTE**

SEZIONE ORIZZONTALE  
NODO CENTRALE  
SCALA 1:1

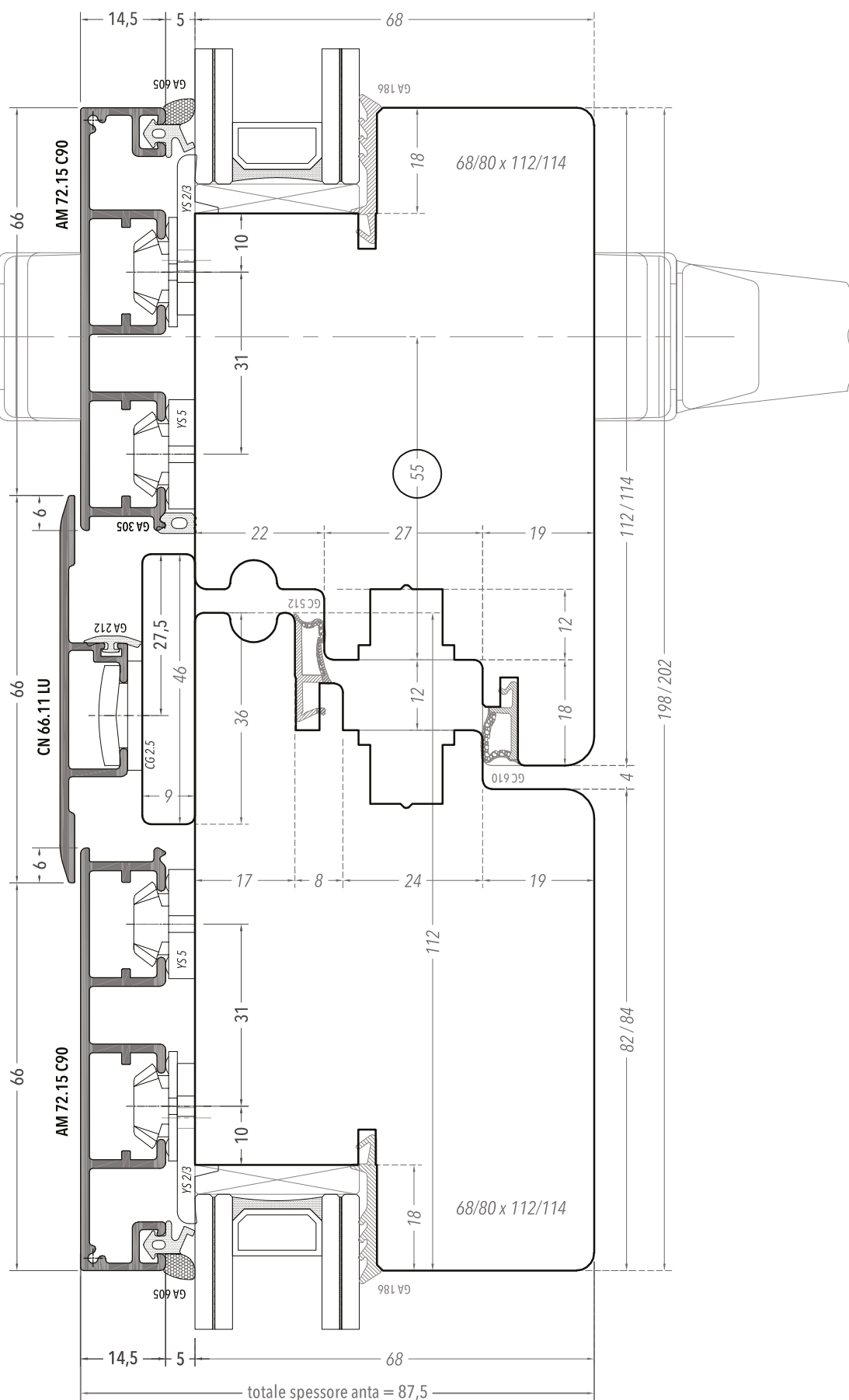
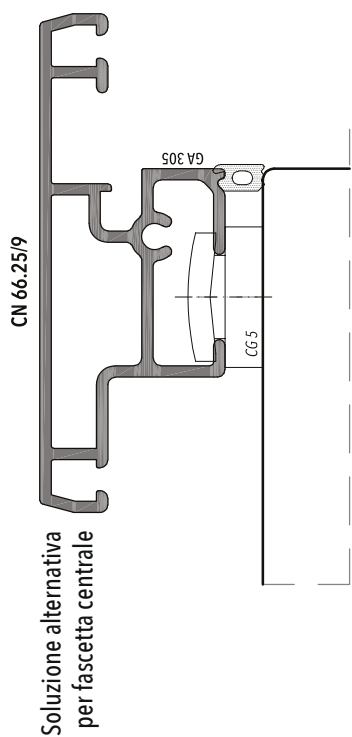

In caso di serratura passante,  
è possibile maggiorare solo  
il montante con la maniglia e  
lasciare invariata la sezione  
anta sugli altri lati.  
Entrata consigliata per la  
serratura: 55 mm.







Spessore telaio 65  
Spessore anta 68  
Per serramenti Freumex

# Alumfast Sistema 16 Eco

---

SLIDE

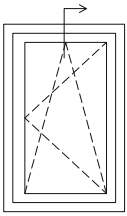

**FINESTRA**

SEZIONE VERTICALE  
NODO SUPERIORE  
SCALA 1:1

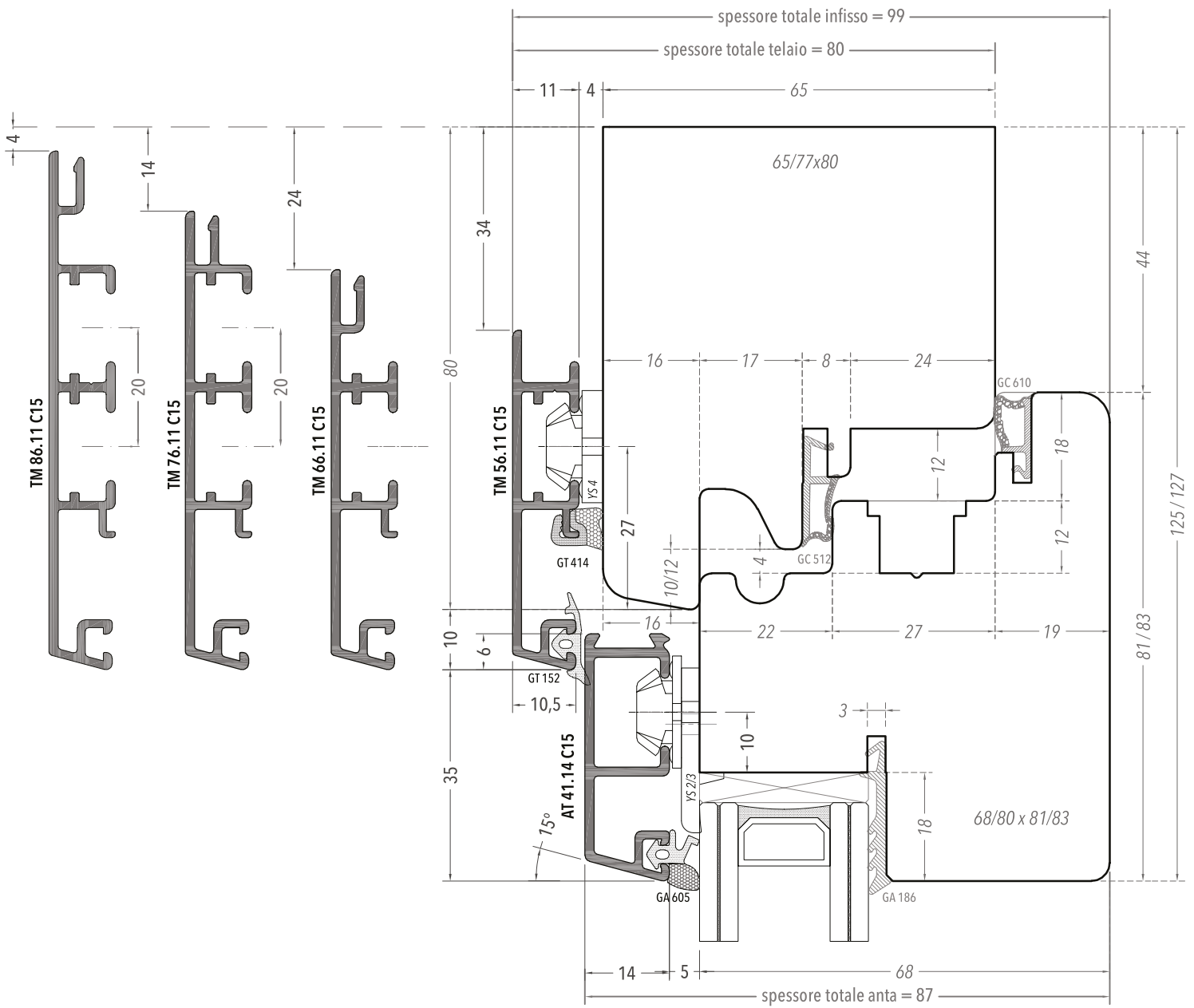

In caso di serramenti in legno-alluminio è sconsigliata l'applicazione della guarnizione GC604.

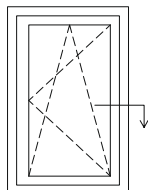

**FINESTRA**

SEZIONE ORIZZONTALE  
 NODO LATERALE  
 SCALA 1:1

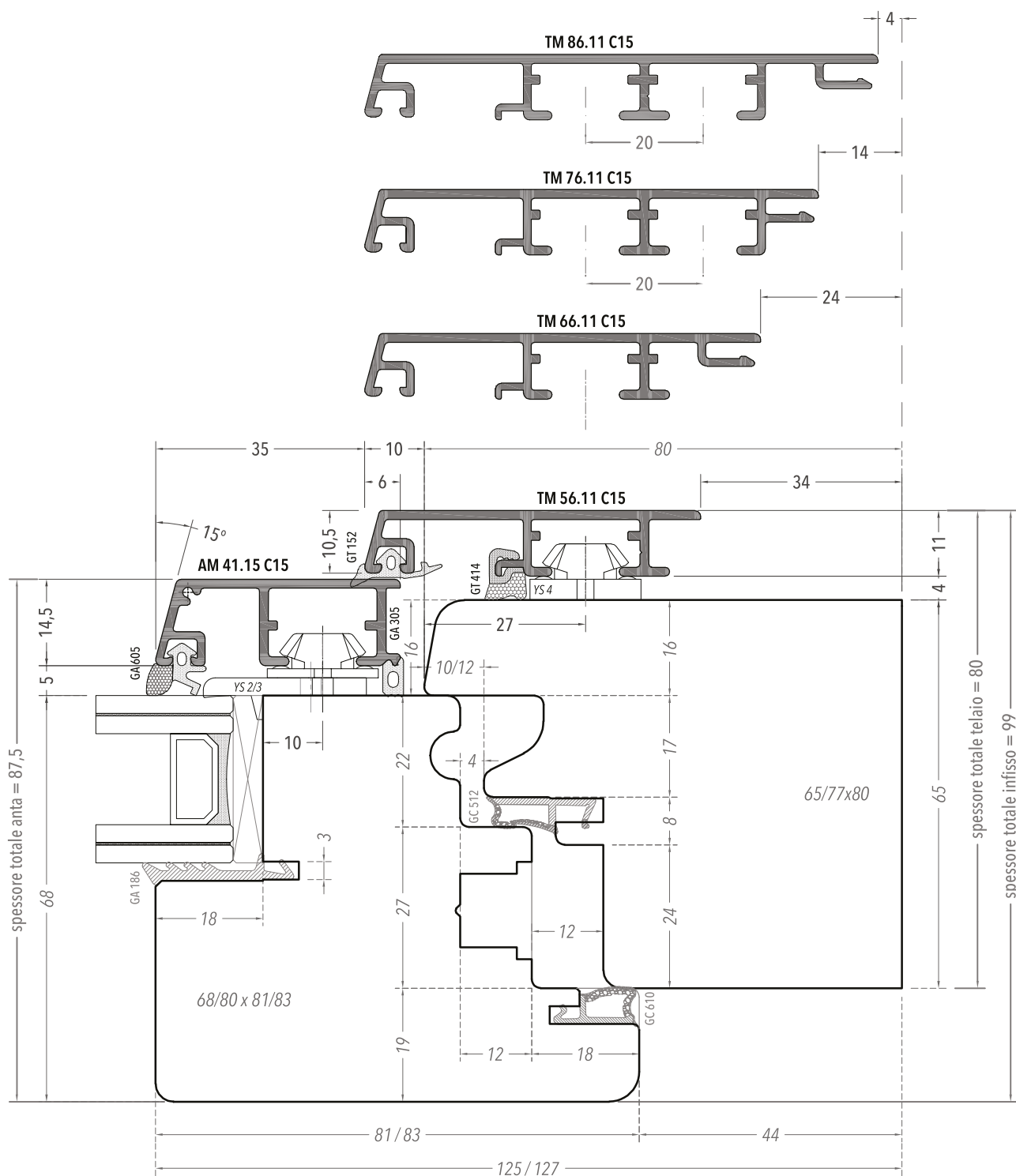

In caso di serramenti in legno-alluminio è sconsigliata l'applicazione della guarnizione GC604.

**PORTAFINESTRA CON SERRATURA PASSANTE**

SEZIONE VERTICALE  
NODO SUPERIORE  
SCALA 1:1

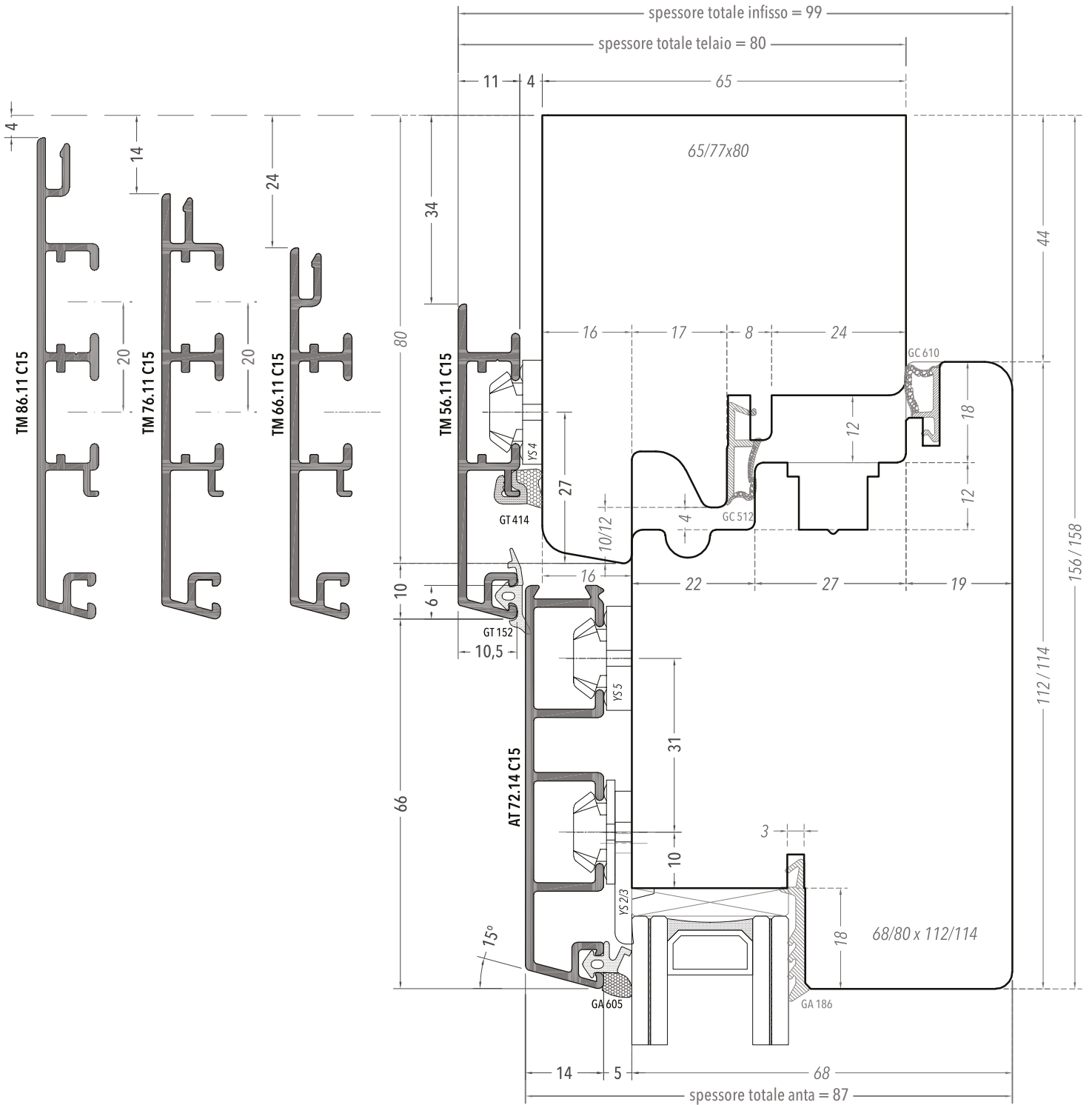
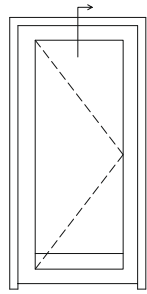

In caso di serramenti in legno-alluminio è sconsigliata l'applicazione della guarnizione della GC604.

**PORTAFINESTRA CON SERRATURA PASSANTE**

SEZIONE ORIZZONTALE  
NODO LATERALE  
SCALA 1:1

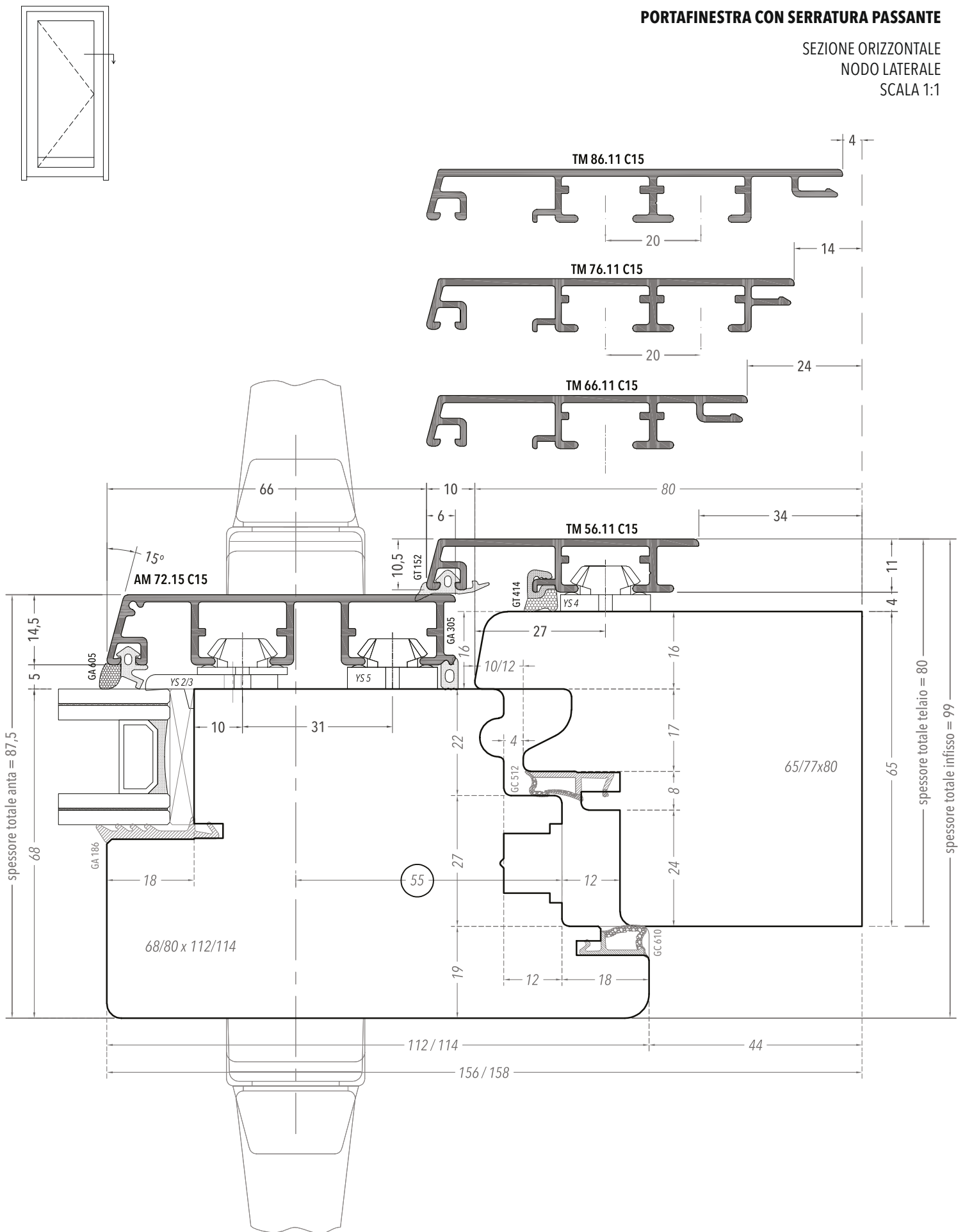

In caso di serratura passante, è possibile maggiorare solo il montante con la maniglia e lasciare invariata la sezione anta sugli altri lati.  
Entrata consigliata per la serratura: 55 mm.



Spessore telaio 65  
Spessore anta 68  
Per serramenti Freumex



# Alumfast Sistema 16 Eco

---

ABBINAMENTI

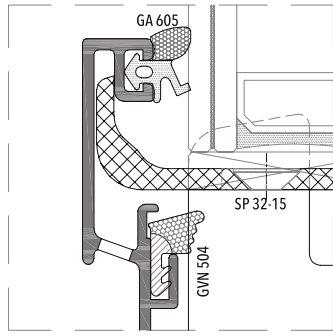
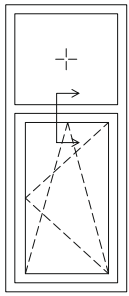

**APRIBILE CON SOPRA-LUCE**

SEZIONE VERTICALE  
NODO ABBINAMENTO  
SCALA 1:1

Variante con guarnizione  
GVN 504



Siliconatura dei listelli in legno

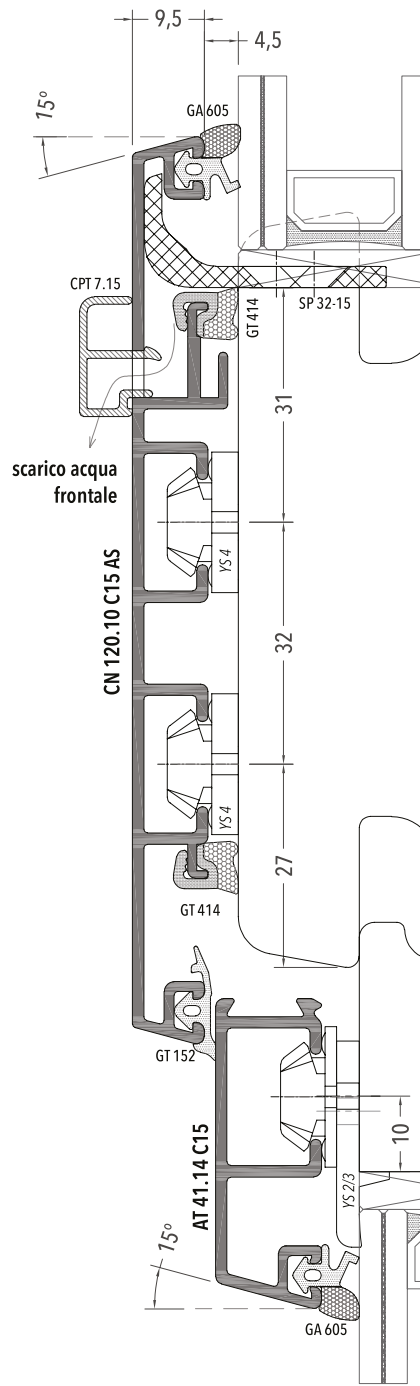

Variante Slide

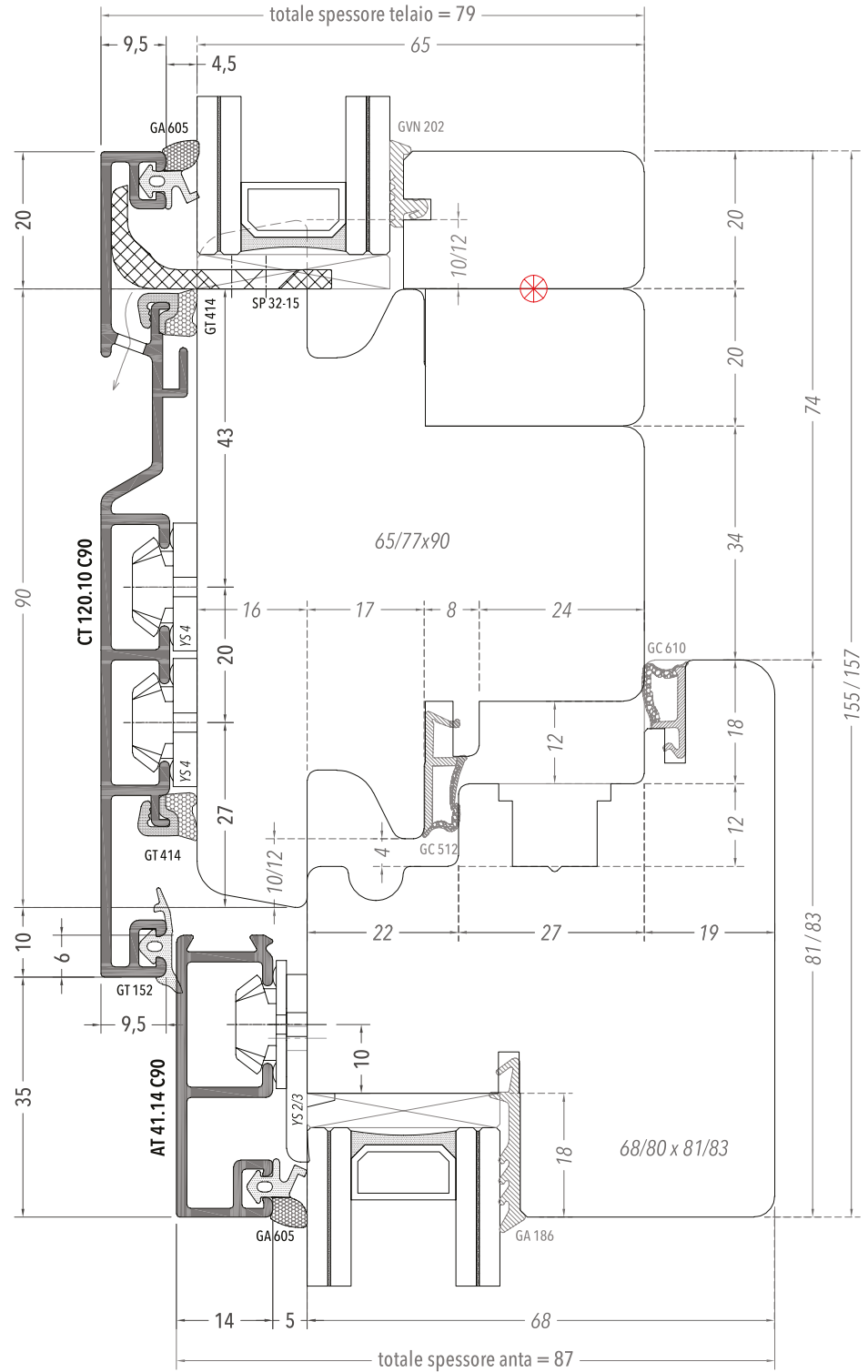

In caso di abbinamenti a telaio unico con sopra-luce, sotto-luce e fianco-luce fisso per Sistema 16 Eco, è necessario eseguire una lavorazione particolare sulla battuta più esterna del telaio (vedi tratteggio nel disegno).

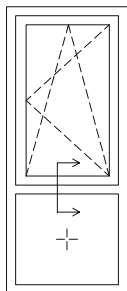

**APRIBILE CON SOTTO-LUCE**

SEZIONE VERTICALE  
NODO ABBINAMENTO  
SCALA 1:1

 Siliconatura dei listelli in legno

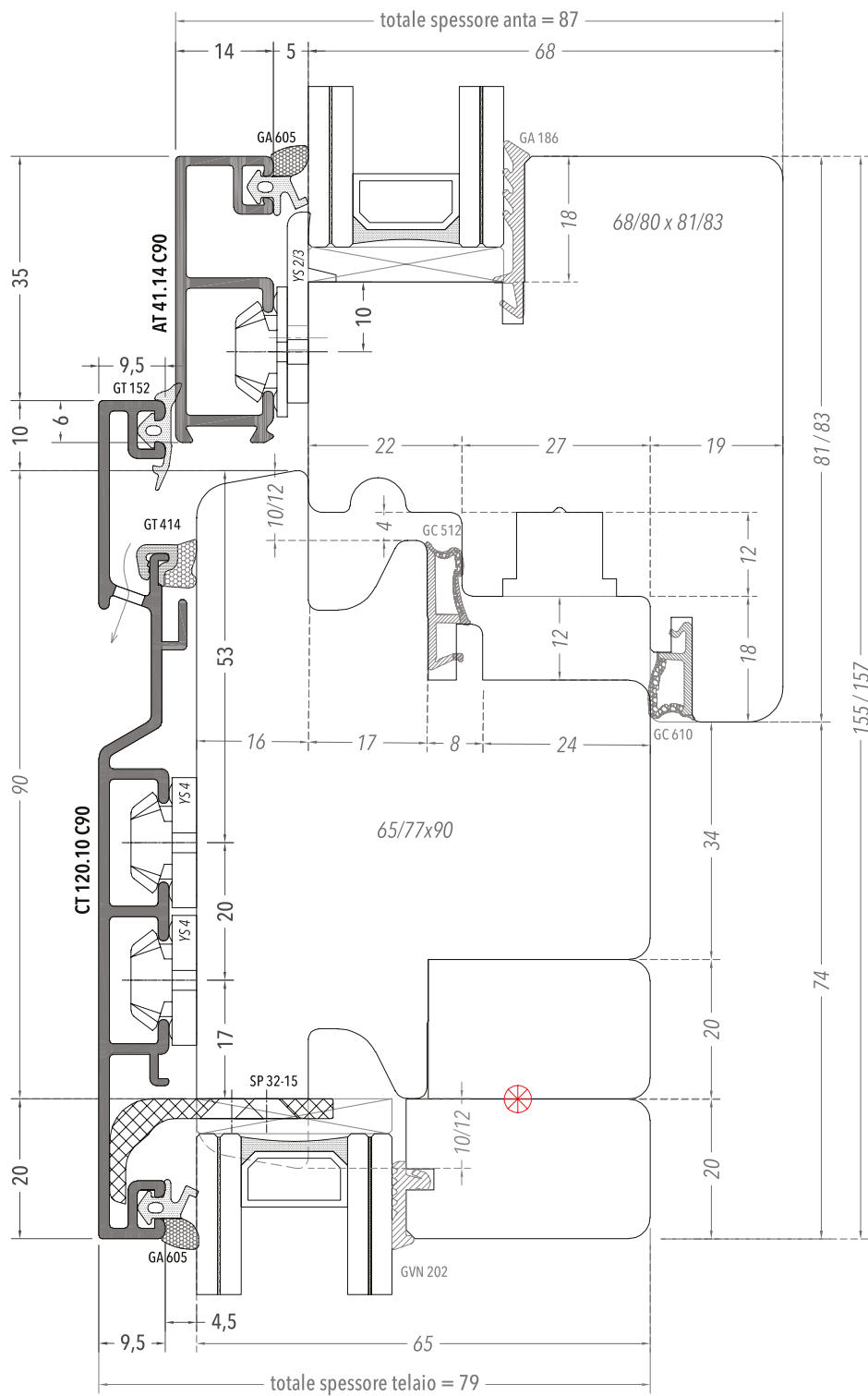
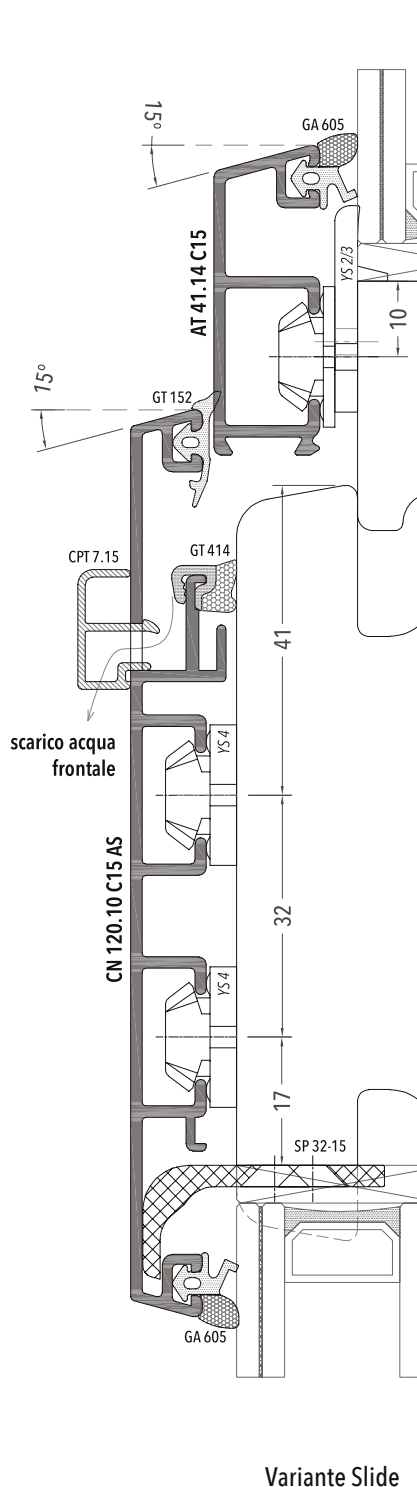

In caso di abbinamenti a telaio unico con sopra-luce, sotto-luce e fianco-luce fisso per Sistema 16 Eco, è necessario eseguire una lavorazione particolare sulla battuta più esterna del telaio (vedi tratteggio nel disegno).

# FINESTRA CON SOPRA-LUCE APRIBILE

SEZIONE VERTICALE  
NODO ABBINAMENTO  
SCALA 1:1

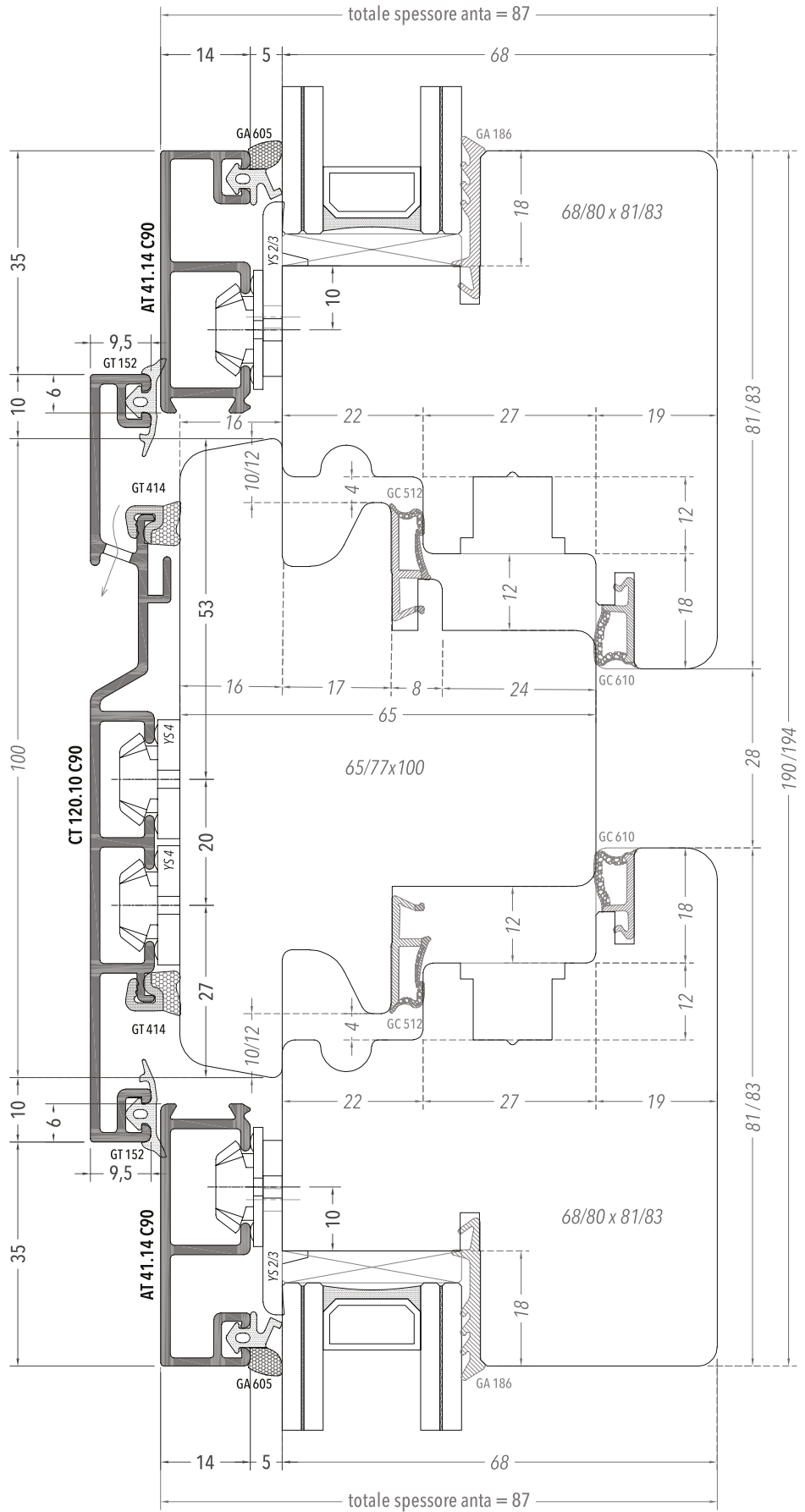
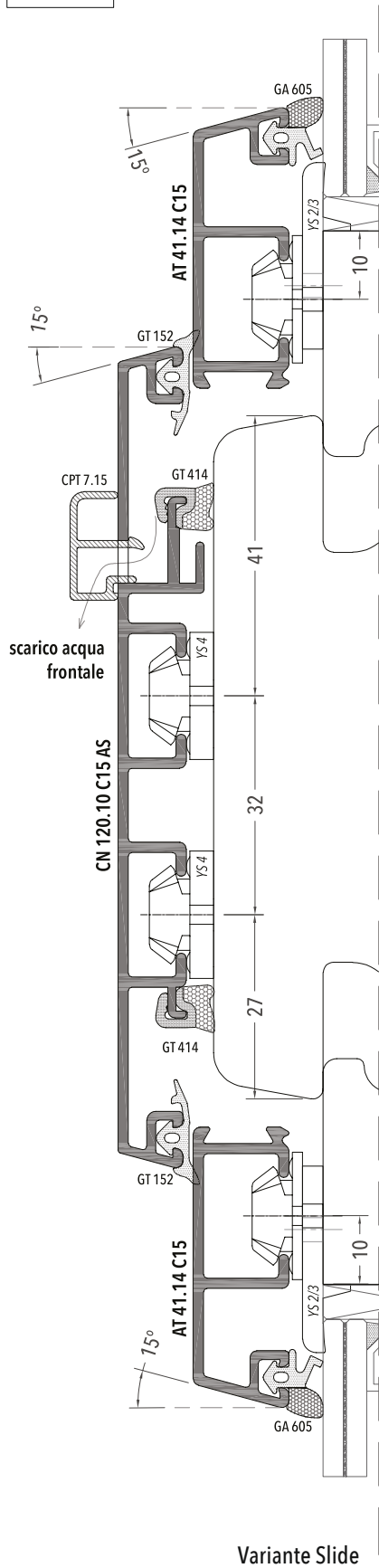
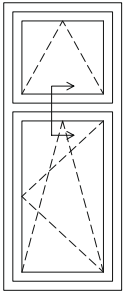

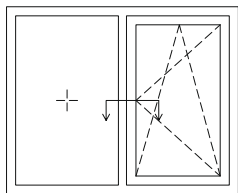

## FINESTRA CON FIANCO-LUCE

SEZIONE ORIZZONTALE  
NODO ABBINAMENTO  
SCALA 1:1

 Siliconatura dei listelli in legno

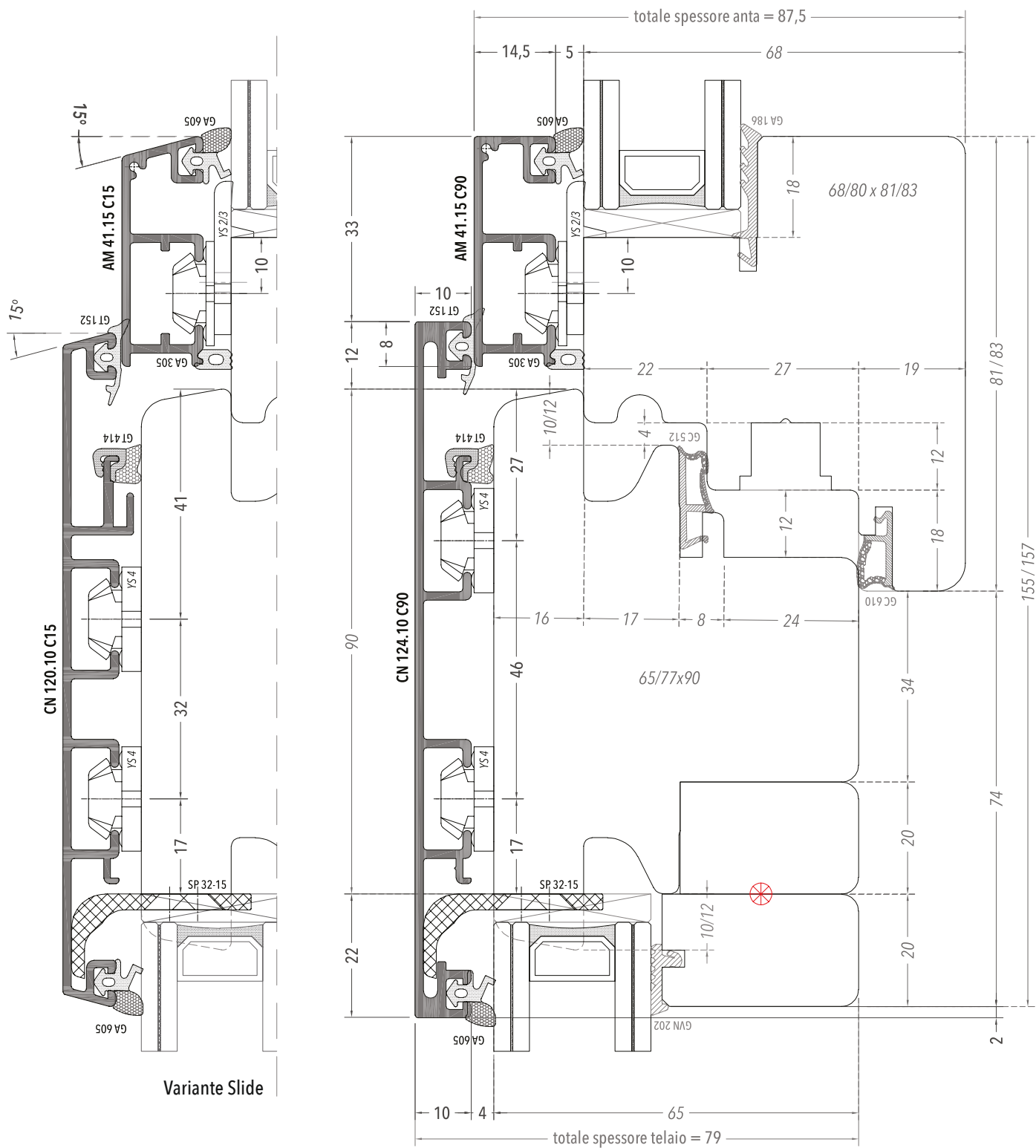

Variante Slide

In caso di abbinamenti a telaio unico con sopra-luce, sotto-luce e fianco-luce fisso per Sistema 16 Eco, è necessario eseguire una lavorazione particolare sulla battuta più esterna del telaio (vedi tratteggio nel disegno).

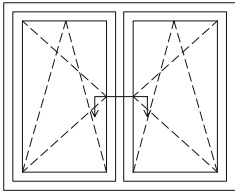

**ABBINAMENTO APRIBILI**

SEZIONE ORIZZONTALE  
NODO CENTRALE  
SCALA 1:1

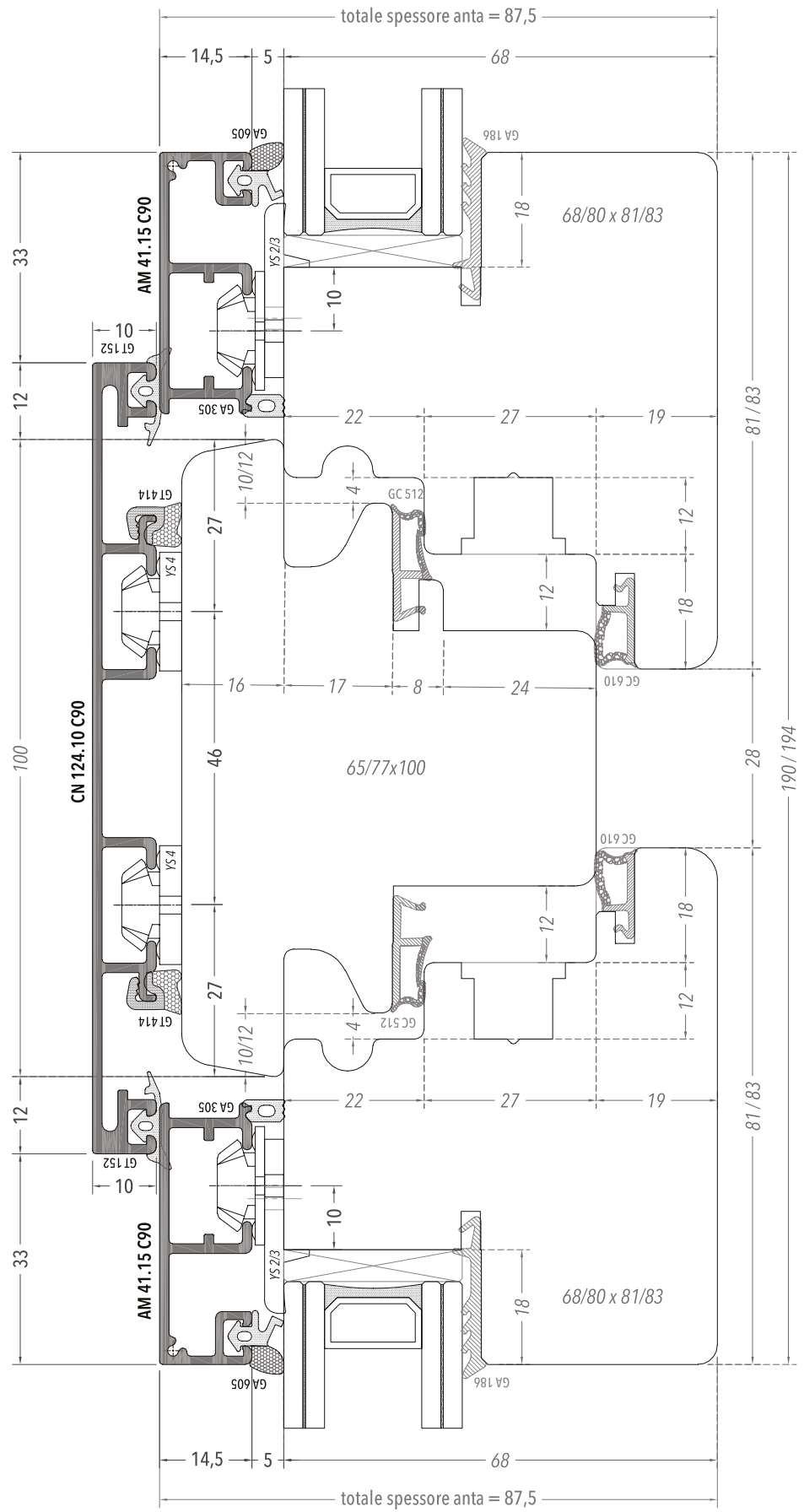
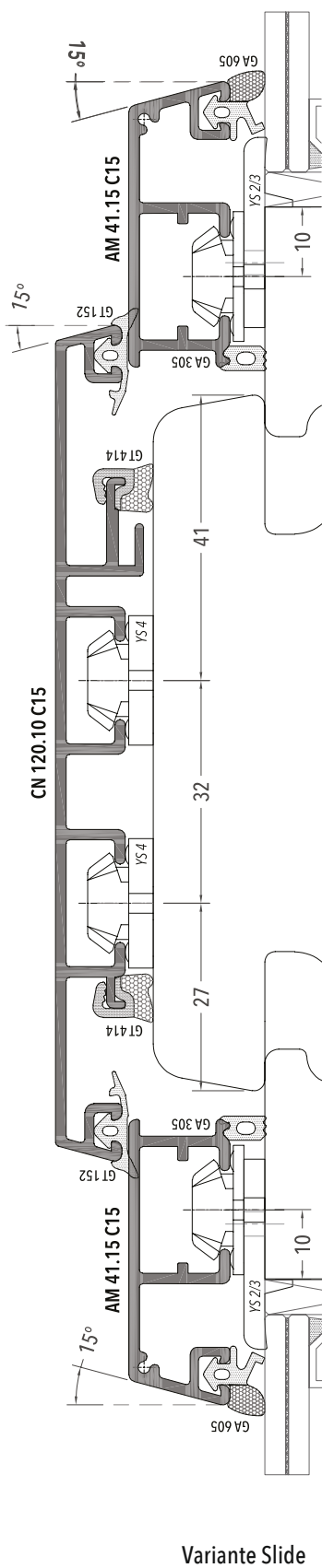







# Alumfast Sistema 16 Eco

---

FISSI

## TELAIO FISSO

Soluzione valida per Sistema 16 Eco.  
Scelta consigliata in caso di abbinamenti  
(sopra-luce, fianco-luce, ecc.).

I profili Standard sono totalmente intercambiabili  
con i profili Slide.

- ⊗ Basetta fermavetro auto-posizionante FV 2.2  
alternata alla clip a scatto (YS 4 o YS 5).
- ⊗ Siliconatura dei listelli in legno.

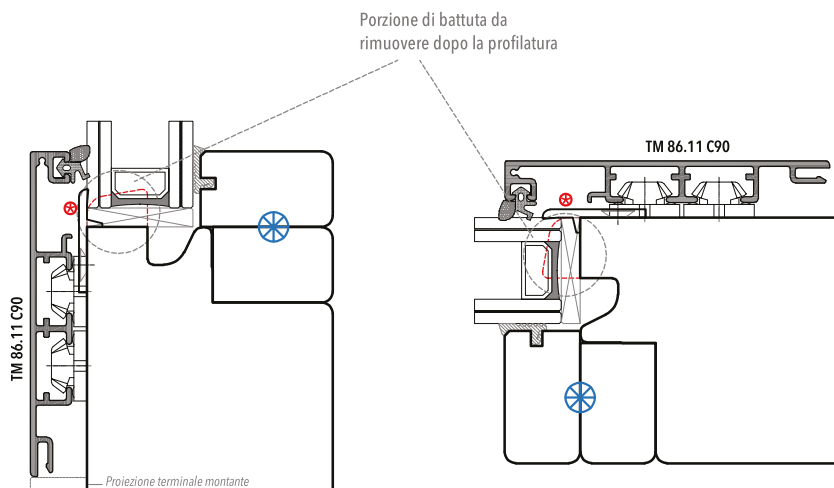

## SOLUZIONI PER SERRAMENTO FISSO

## QUADROTTO CON FERMAVETRO RIPORTATO

Soluzione valida per tutti i sistemi.

I profili Standard sono totalmente intercambiabili  
con i profili Slide.

- ⊗ Basetta fermavetro auto-posizionante FV 2.2  
alternata alla clip a scatto (YS 4 o YS 5).
- ⊗ Siliconatura dei listelli in legno.

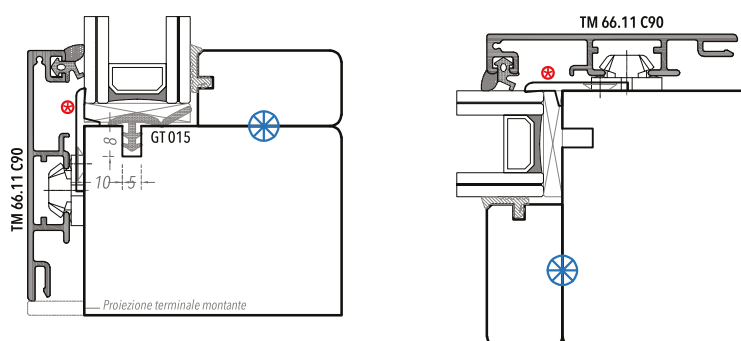

## SOLUZIONI PER SERRAMENTO FISSO

## PROFILO ANTA (CON FERMAVETRO INTEGRATO)

Soluzione valida per tutti i sistemi.

Il vetro è fissato dall'esterno con basette  
auto-posizionanti FV ⊗ alternate alle clip a scatto  
(YS 4 o YS 5).

I profili Standard sono totalmente intercambiabili  
con i profili Slide.

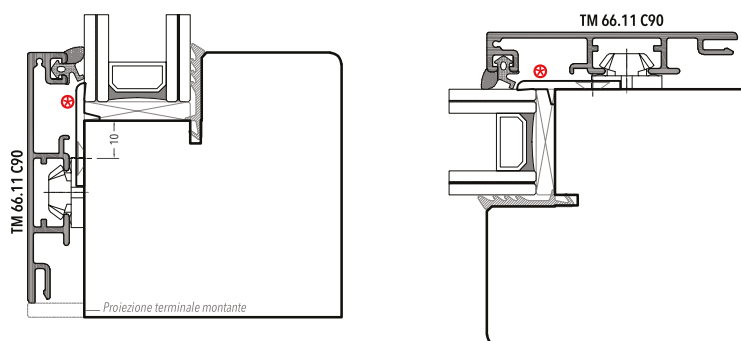

Le dimensioni del nodo dipendono dal tipo di profilo che si intende utilizzare. Possono essere applicati tutti i profili telaio illustrati delle pagine precedenti.





Spessore telaio 65  
Spessore anta 68

# Alumfast Easy

---

STANDARD

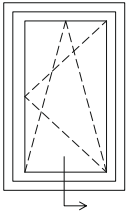

**FINESTRA**

SEZIONE VERTICALE  
NODO INFERIORE  
SCALA 1:1

Variante traverso inferiore con profilo Slide inclinato a 15°

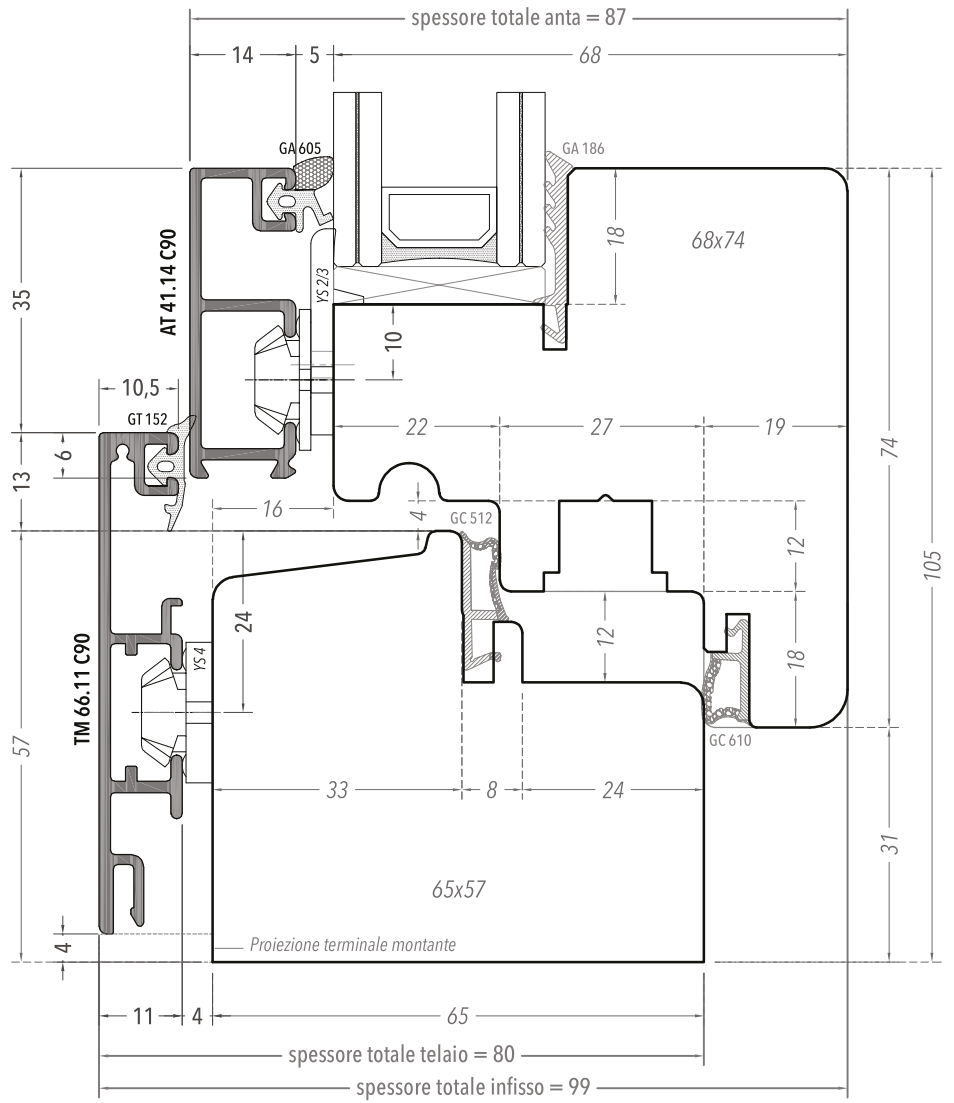
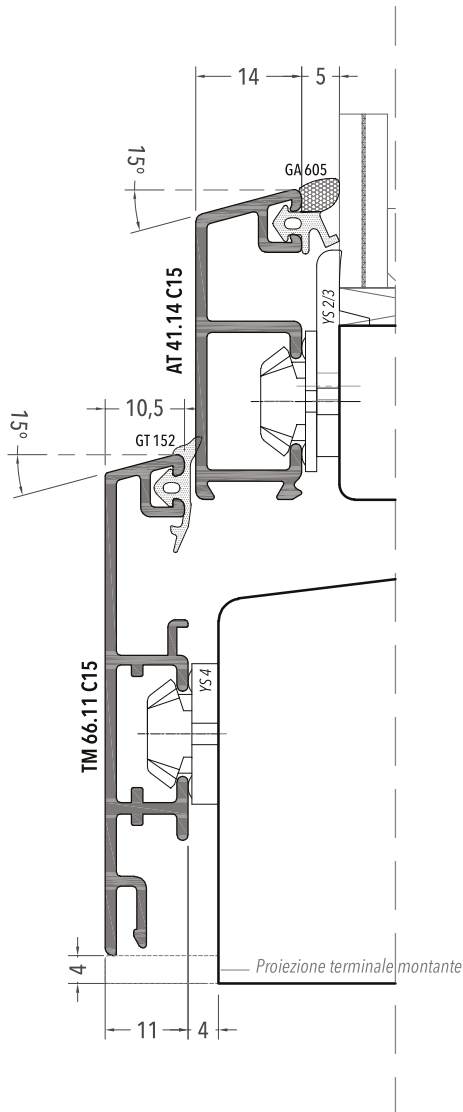

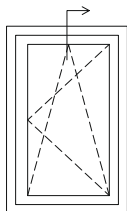

**FINESTRA**  
 SEZIONE VERTICALE  
 NODO SUPERIORE  
 SCALA 1:1

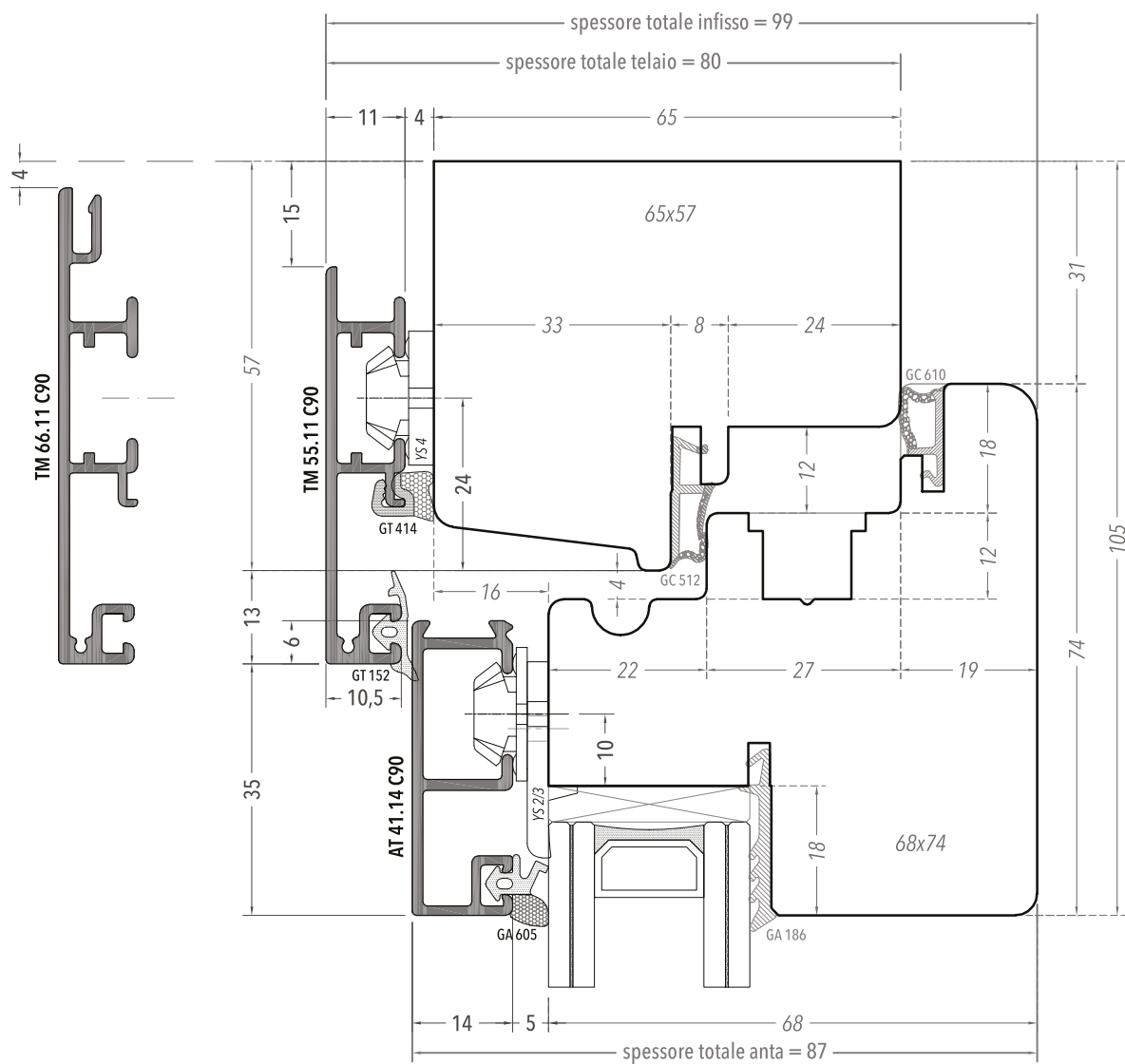

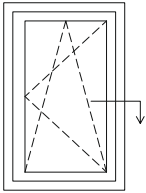

**FINESTRA**

SEZIONE ORIZZONTALE  
NODO LATERALE  
SCALA 1:1

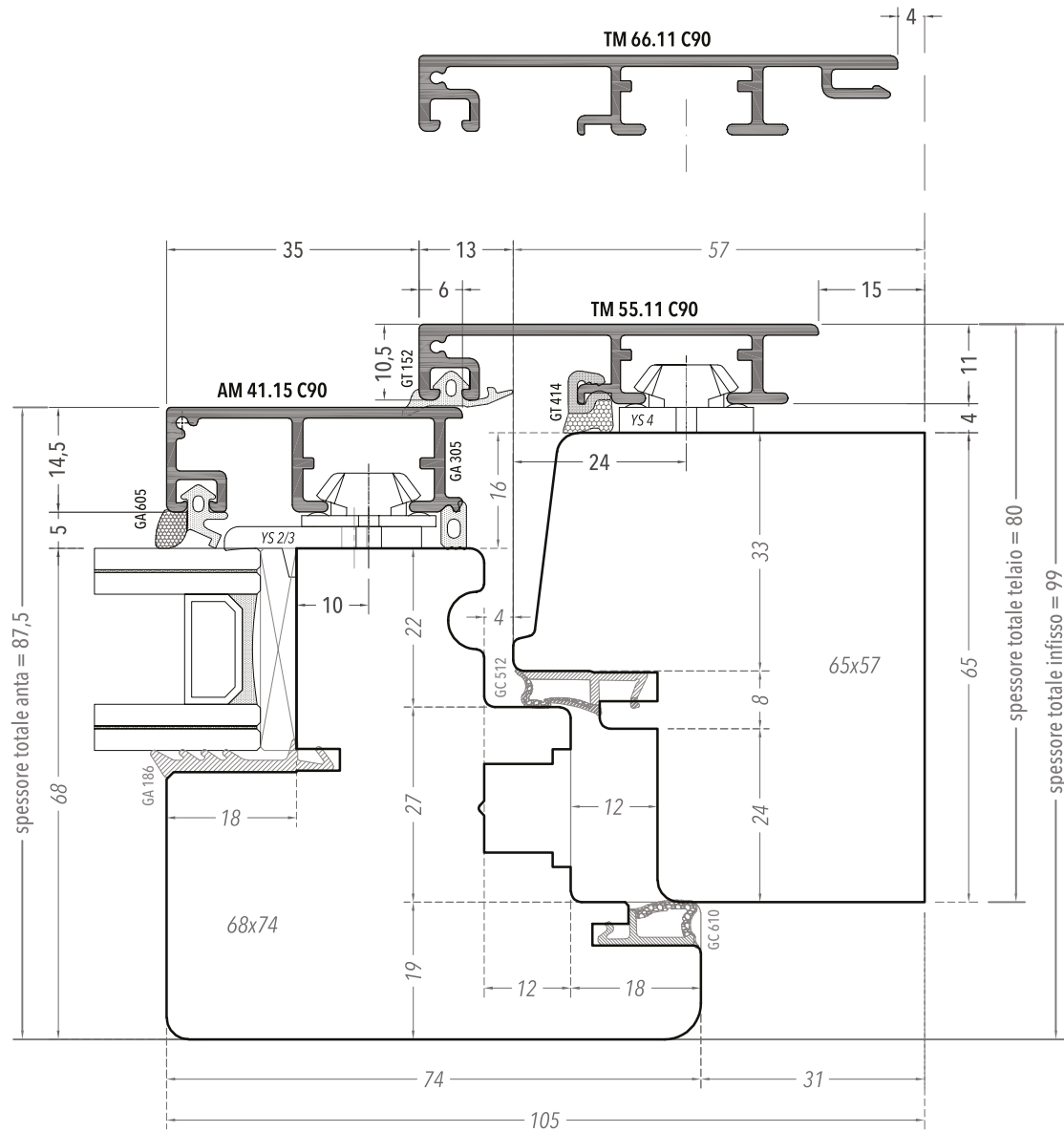



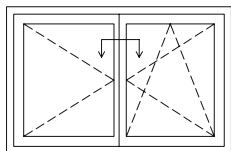

**FINESTRA**

SEZIONE ORIZZONTALE  
NODO CENTRALE  
SCALA 1:1

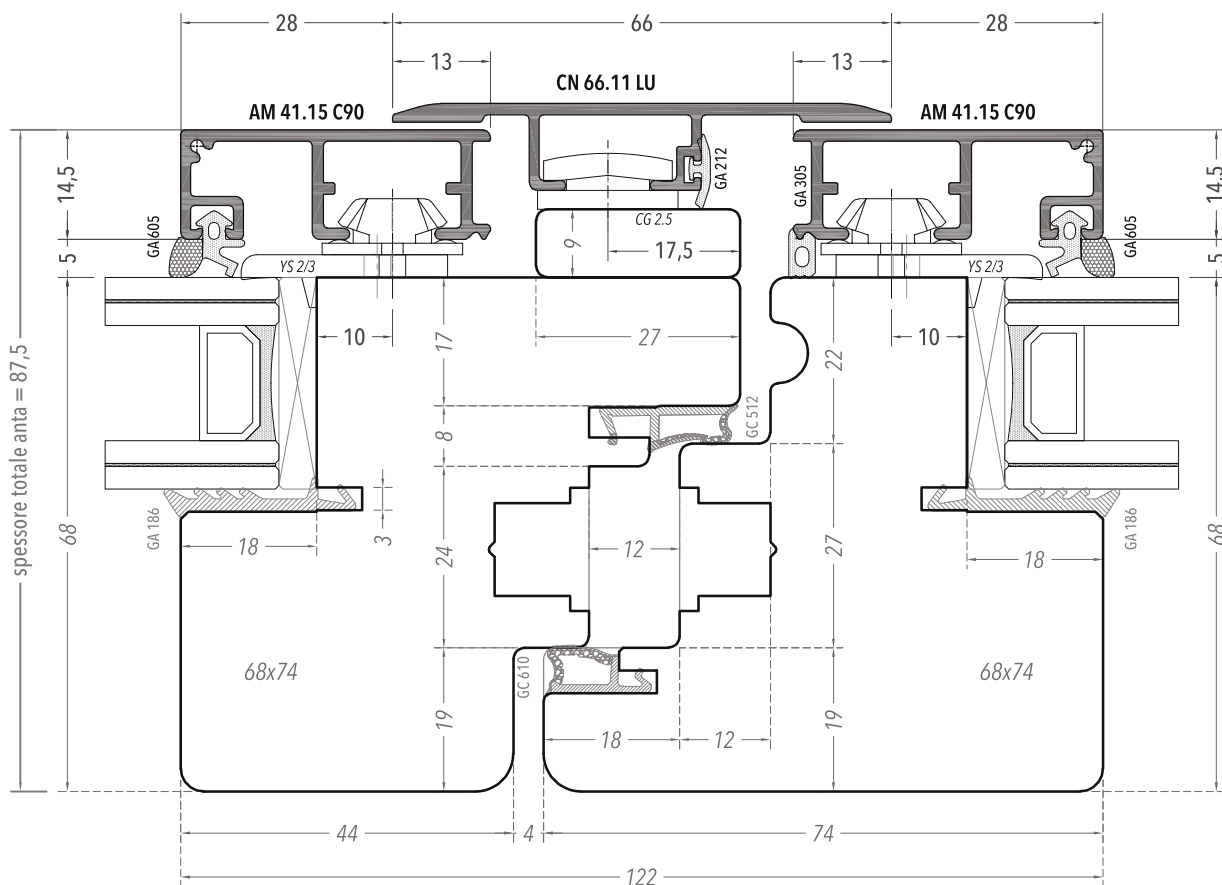
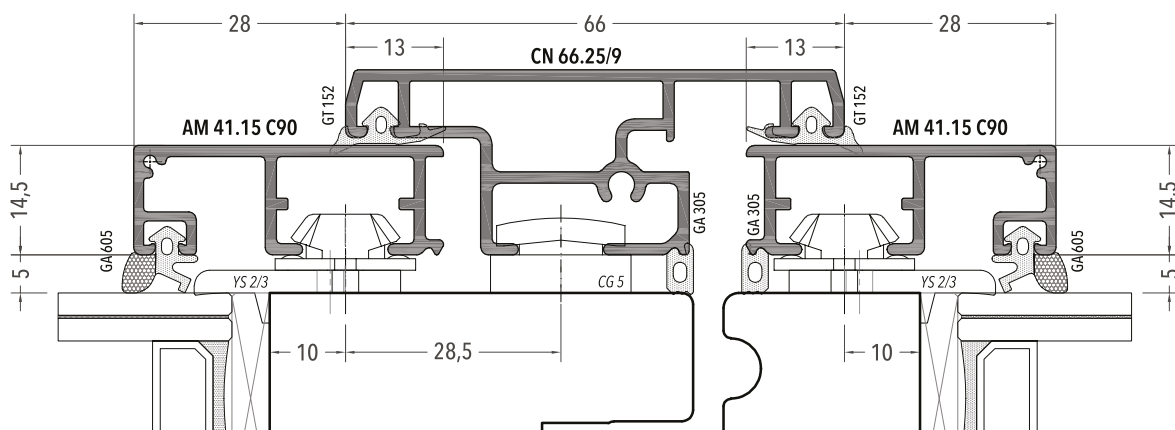

Per il disegno del nodo con montantino aggiunto, consulta la pagina del montantino Sistema 21 Standard.

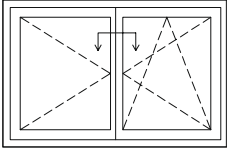

**FINESTRA**

SEZIONE ORIZZONTALE  
NODO CENTRALE CON MONTANTINO AGGIUNTO  
SCALA 1:1

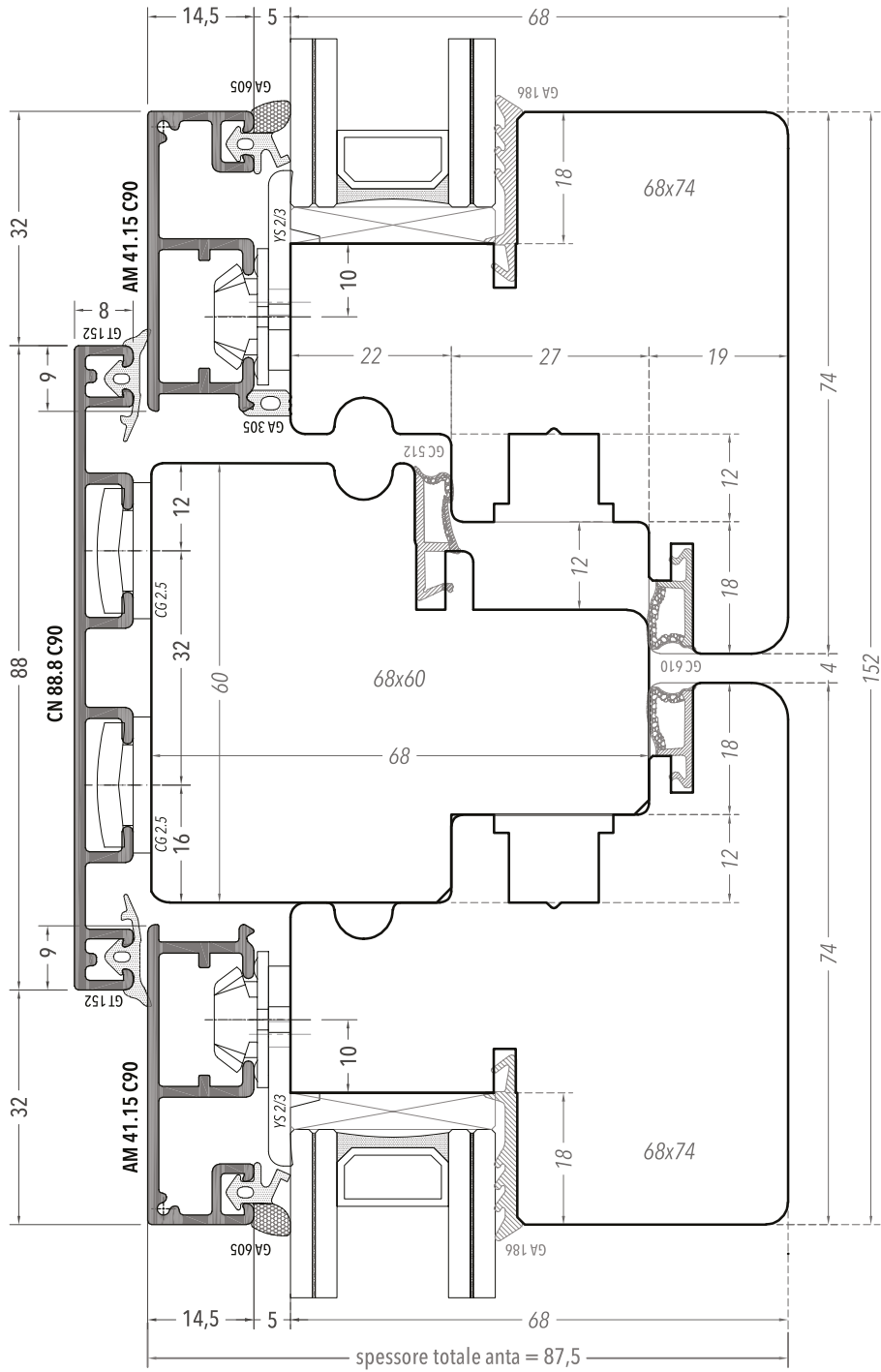

**PORTAFINESTRA**

SEZIONE VERTICALE  
NODO INFERIORE  
SCALA 1:1

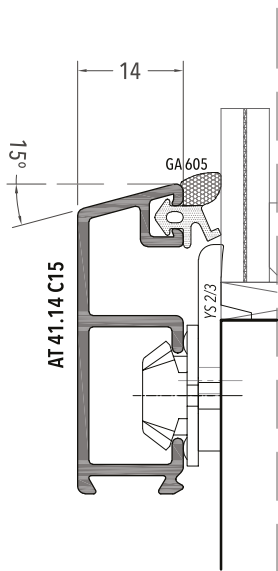
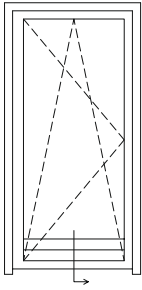

Variante con traverso Slide  
inclinato a 15° su traverso  
inferiore anta

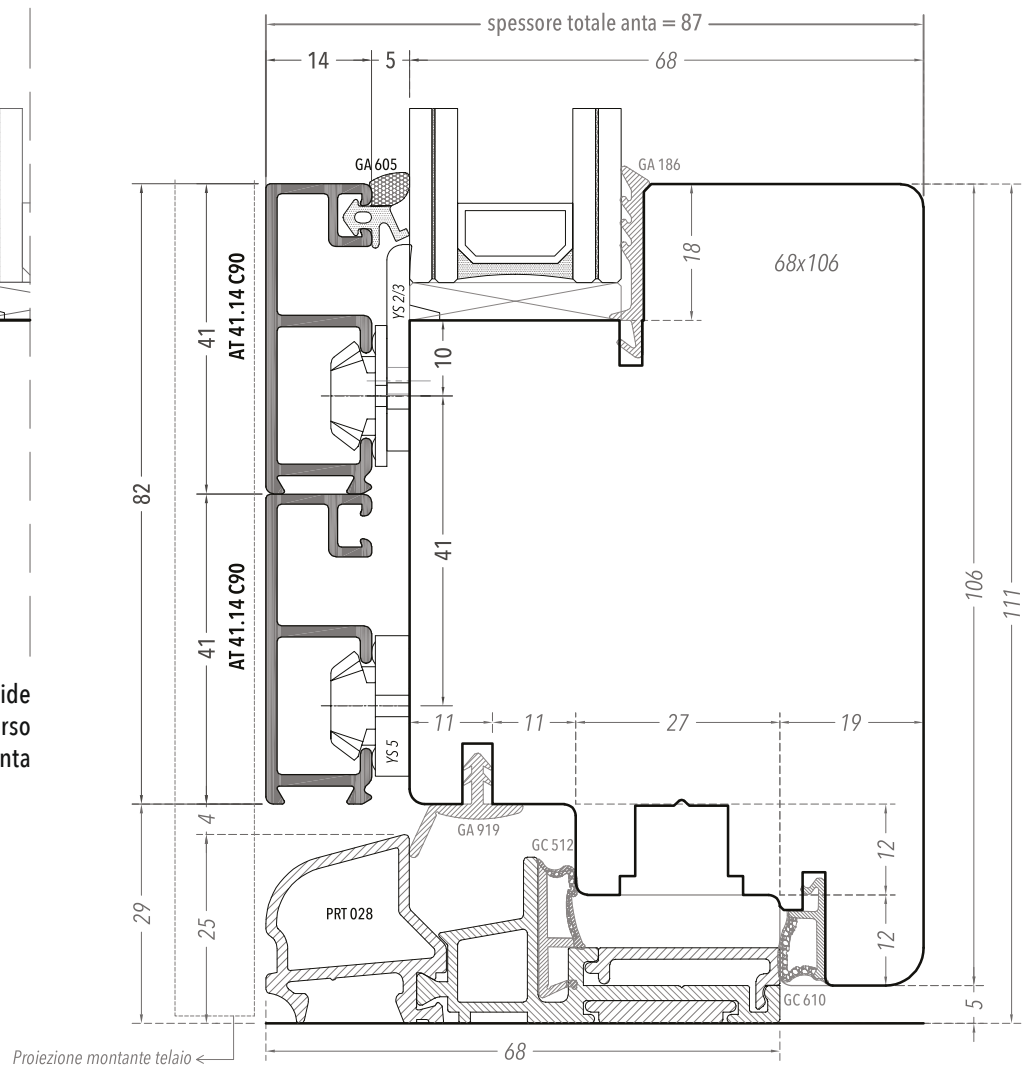

Per tutte le altre combinazioni di profili per gli zoccoli della portafinestra, consulta le pagine introduttive del catalogo.

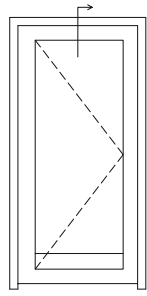

**PORTAFINESTRA CON SERRATURA PASSANTE**

SEZIONE VERTICALE  
 NODO SUPERIORE  
 SCALA 1:1

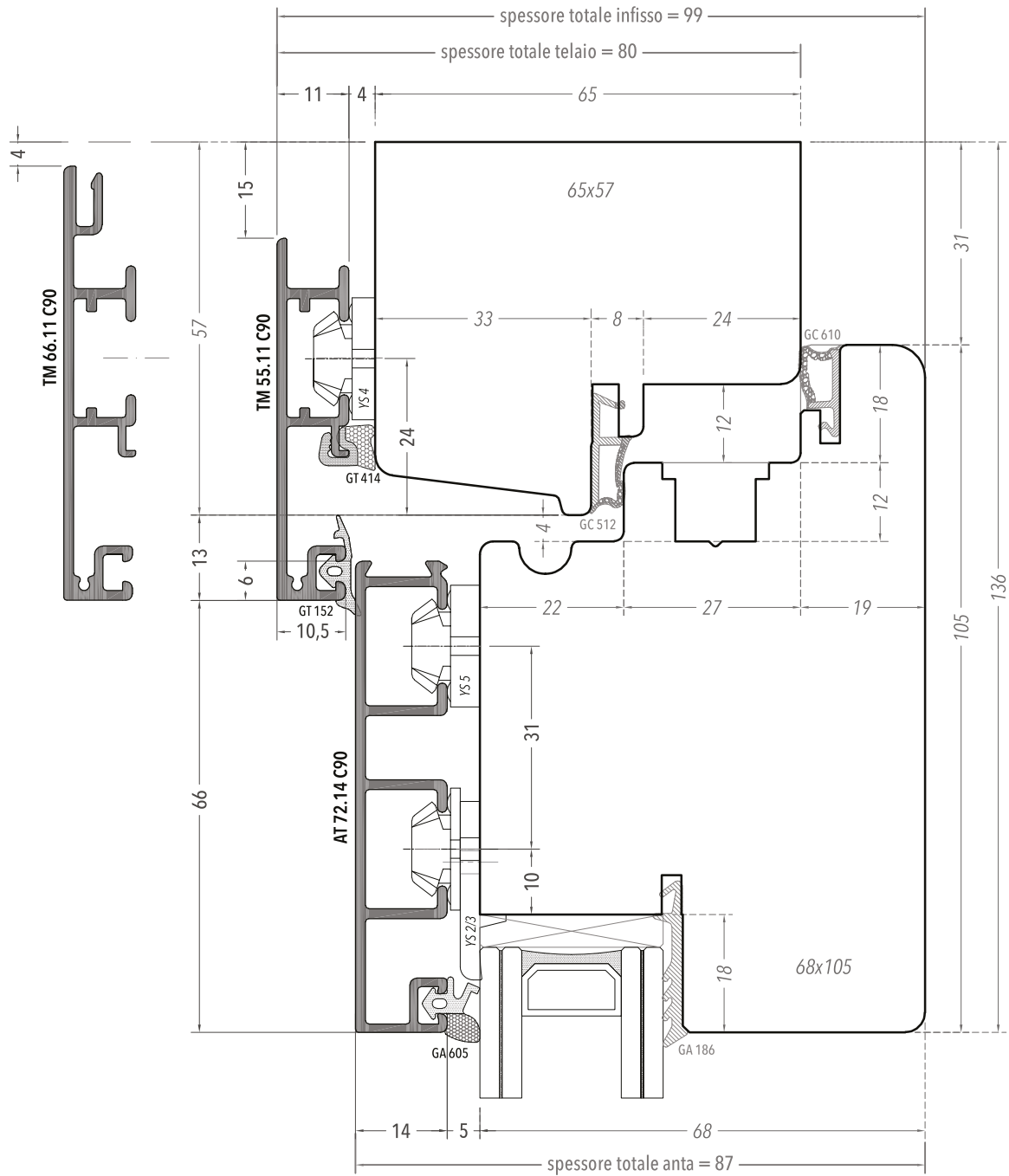

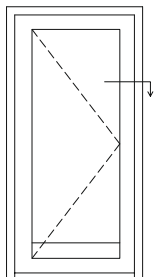

**PORTAFINESTRA CON SERRATURA PASSANTE**

SEZIONE ORIZZONTALE  
 NODO LATERALE  
 SCALA 1:1

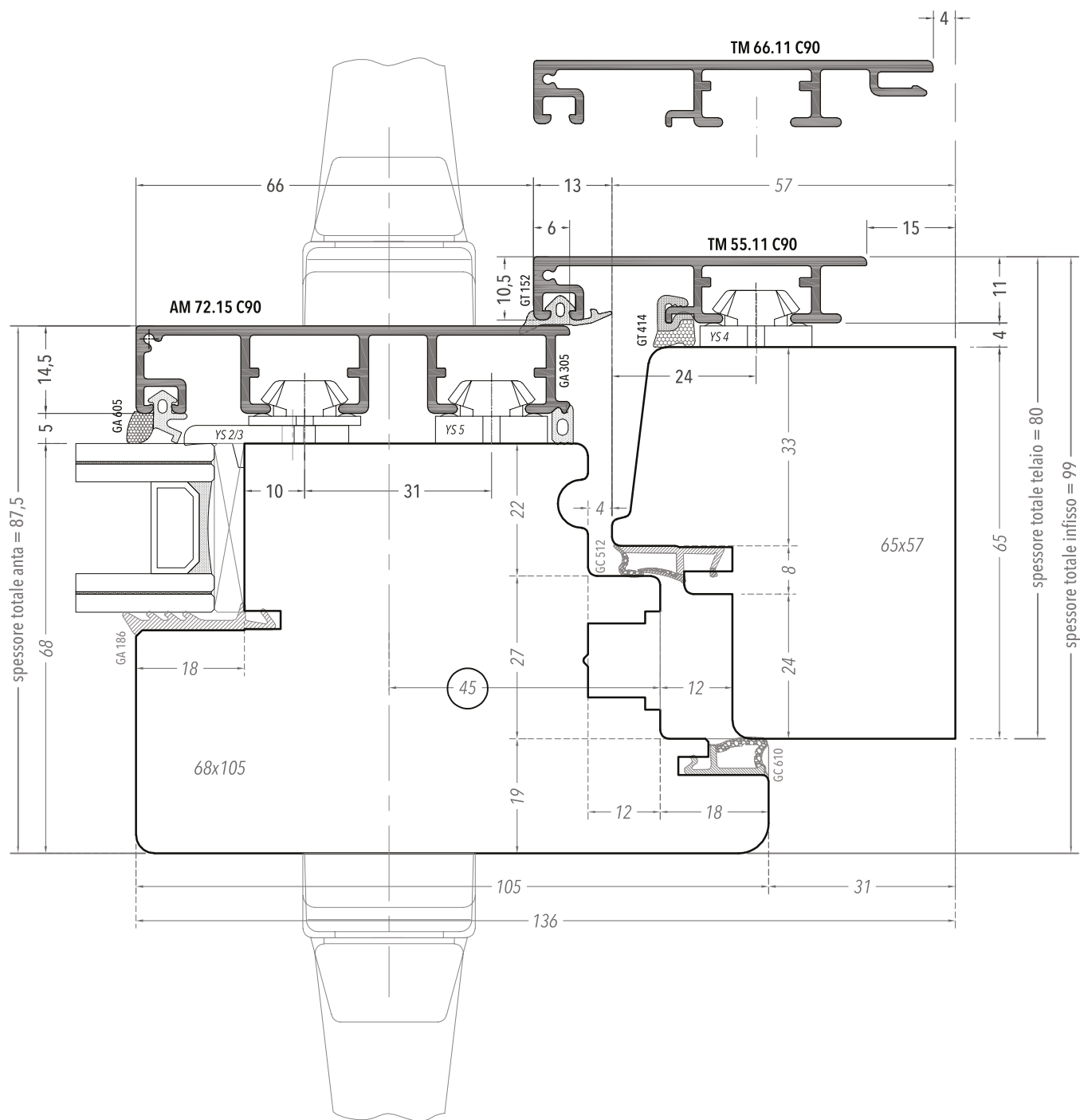

In caso di serratura passante, è possibile maggiorare solo il montante con la maniglia e lasciare invariata la sezione anta sugli altri lati.  
 Entrata consigliata per la serratura: 45 mm.



Spessore telaio 65  
Spessore anta 68

# Alumfast Easy

---

SLIDE

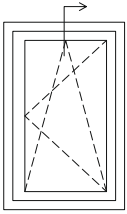

**FINESTRA**

SEZIONE VERTICALE  
NODO SUPERIORE  
SCALA 1:1

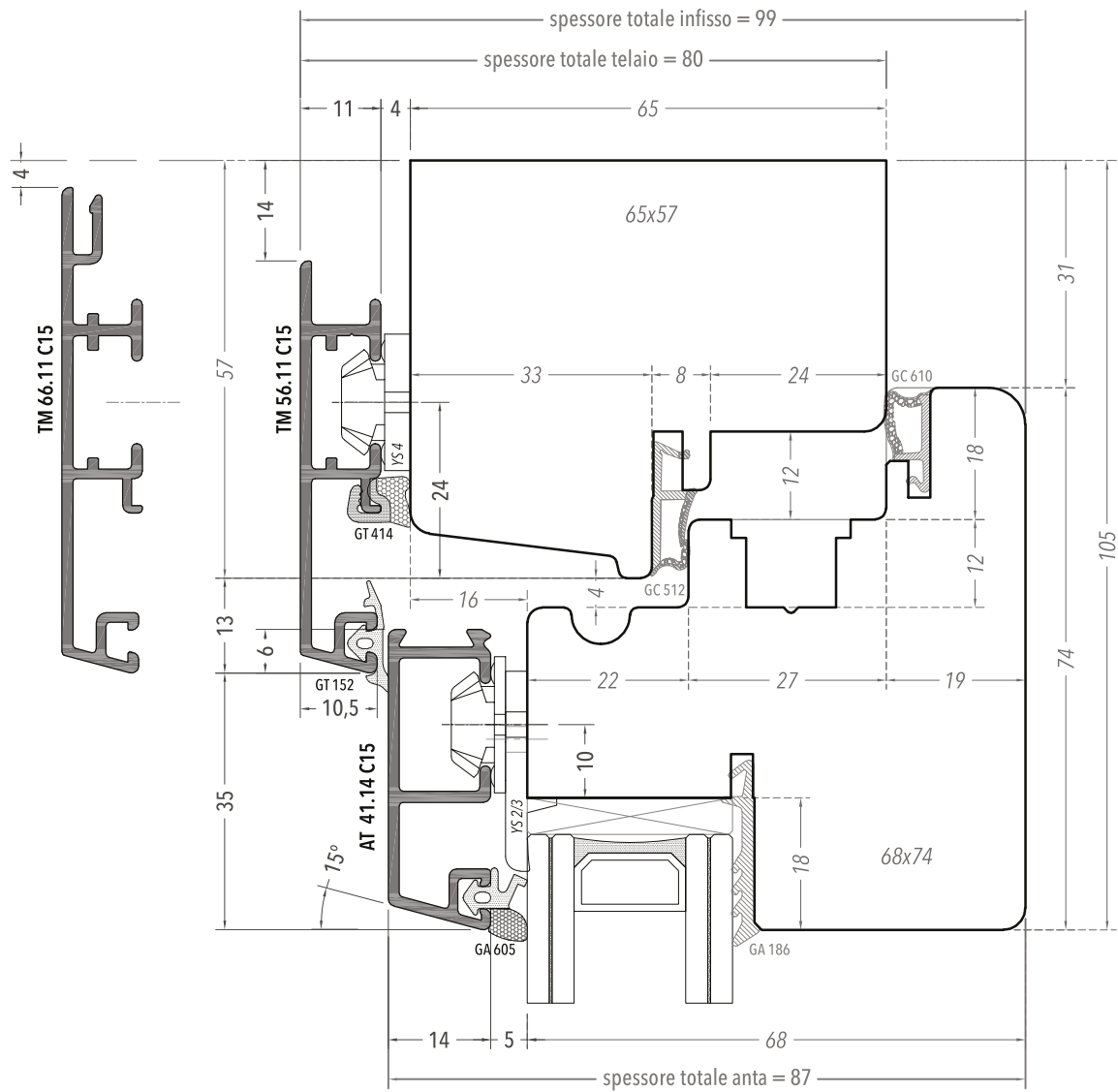



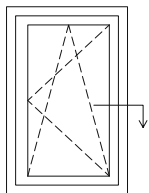

**FINESTRA**

SEZIONE ORIZZONTALE  
 NODO LATERALE  
 SCALA 1:1

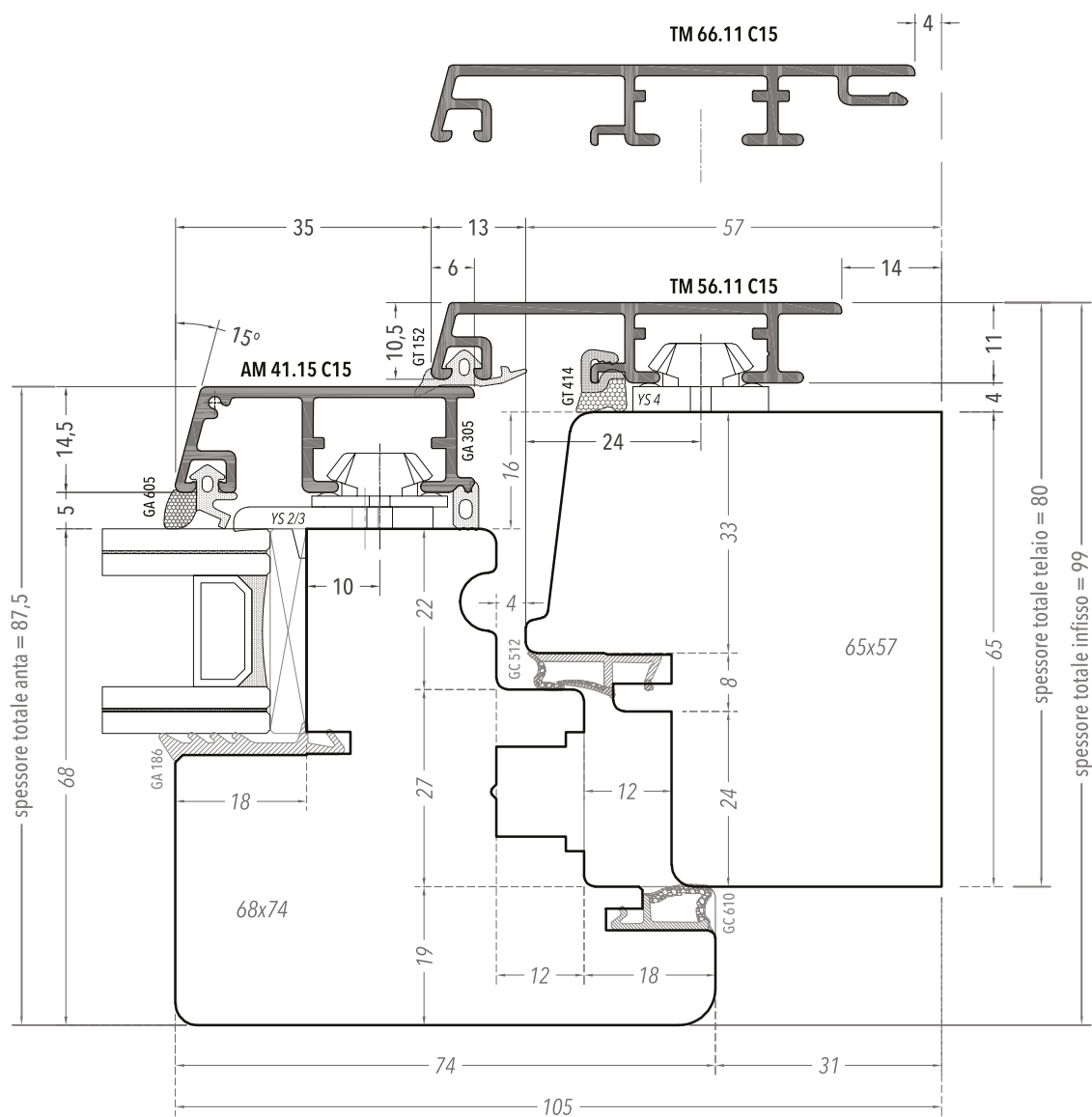

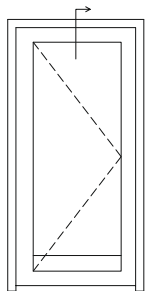

**PORTAFINESTRA CON SERRATURA PASSANTE**

SEZIONE VERTICALE  
 NODO SUPERIORE  
 SCALA 1:1

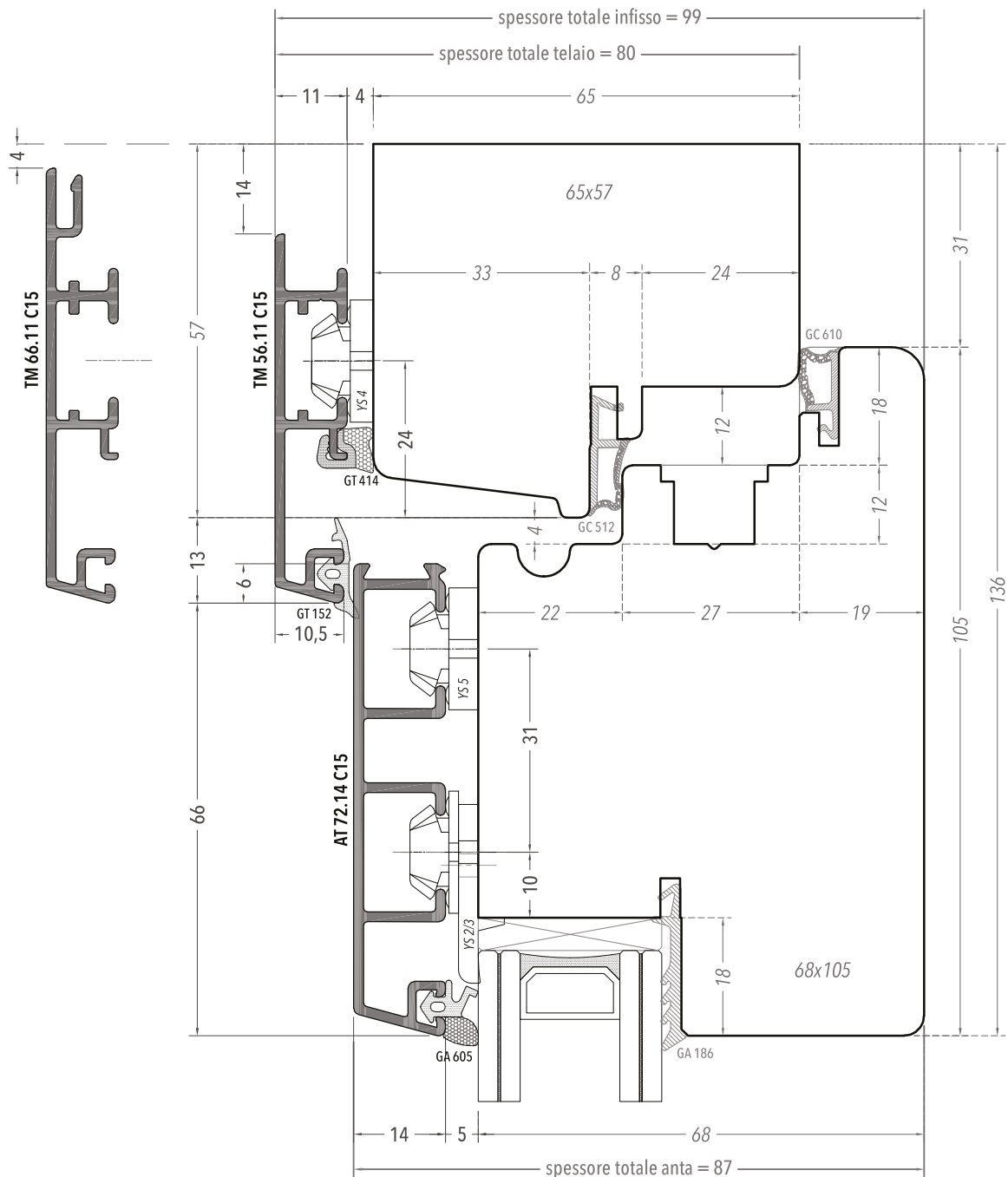

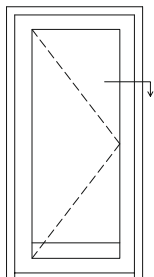

**PORTAFINESTRA CON SERRATURA PASSANTE**

SEZIONE ORIZZONTALE  
 NODO LATERALE  
 SCALA 1:1

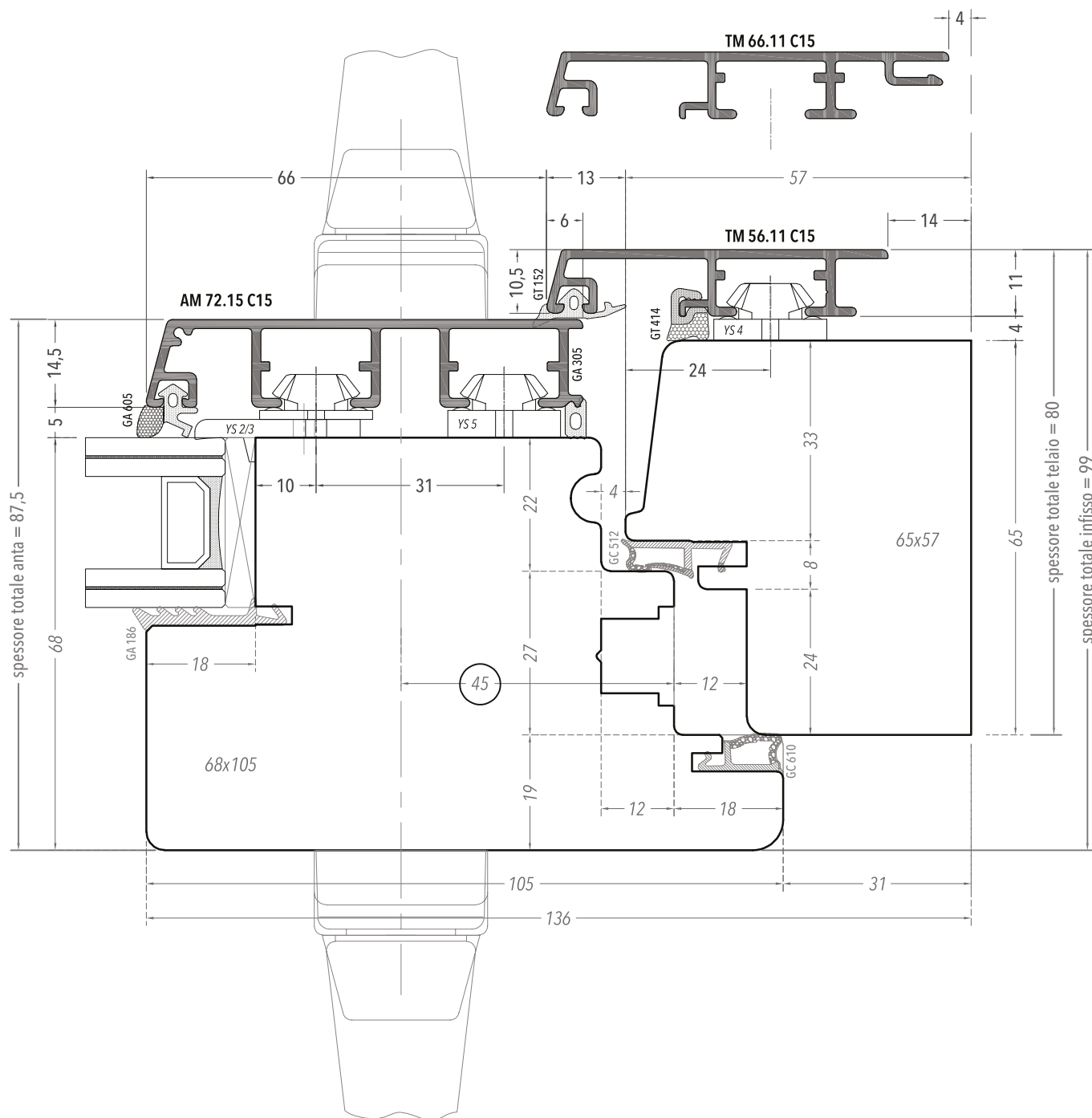

In caso di serratura passante, è possibile maggiorare solo il montante con la maniglia e lasciare invariata la sezione anta sugli altri lati.  
 Entrata consigliata per la serratura: 45 mm.



Spessore telaio 65  
Spessore anta 68

# Alumfast Easy

---

ABBINAMENTI

**APRIBILE CON SOPRA-LUCE**

SEZIONE VERTICALE  
NODO ABBINAMENTO  
SCALA 1:1

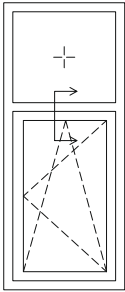

Siliconatura dei listelli in legno

Alternare alla clip a scatto una basetta fermavetro auto-posizionante FV 2.2

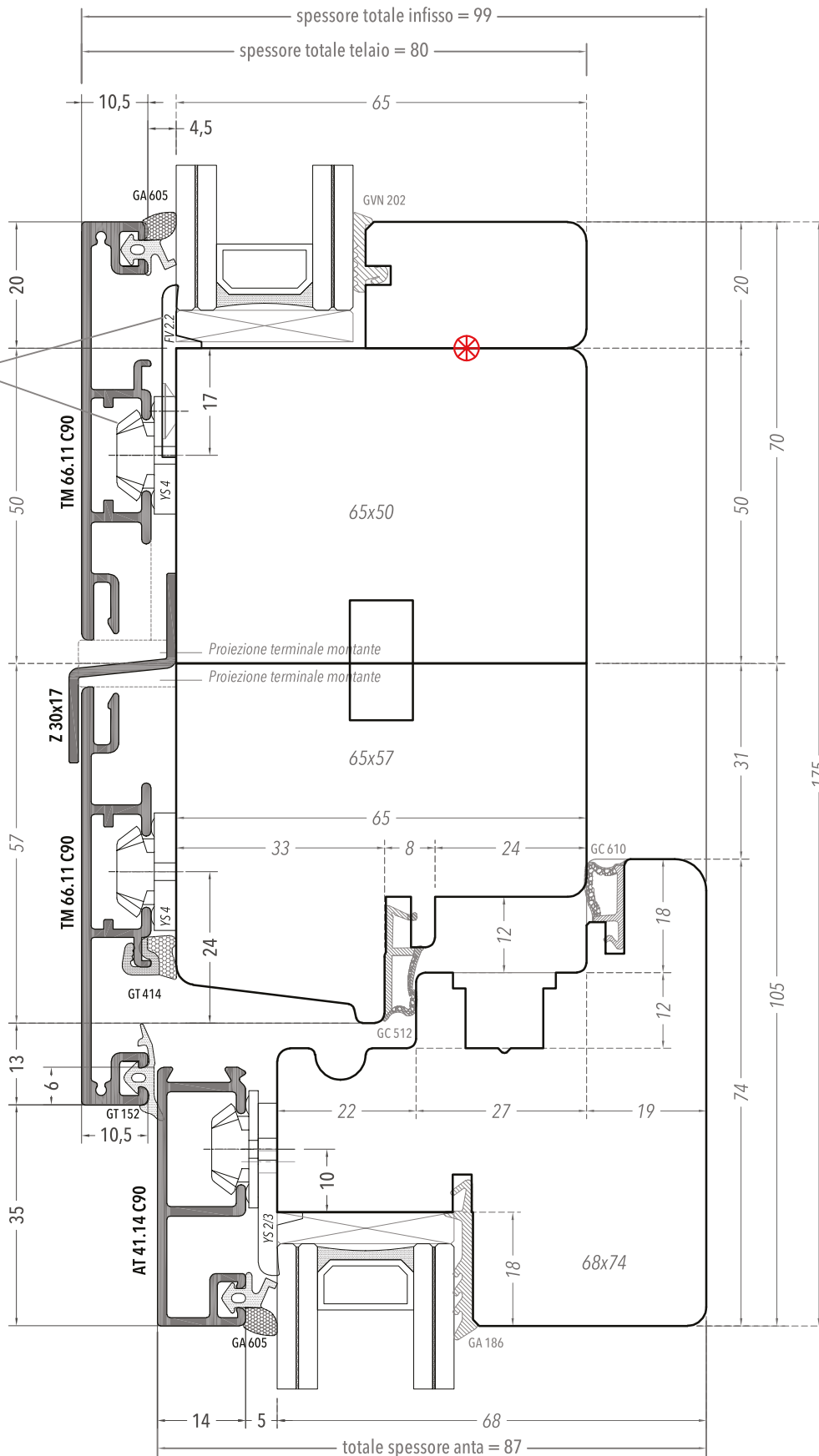

Il lamierino Z30x17 verrà fornito con una lunghezza pari all'esterno telaio. Dovrà essere tagliato a misura luce interna montanti telaio in alluminio.

Soluzione consigliata per abbinamenti di grandi dimensioni.

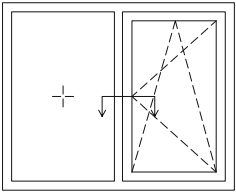

## FINESTRA CON FIANCO-LUCE

SEZIONE ORIZZONTALE  
NODO ABBINAMENTO  
SCALA 1:1

 Siliconatura dei listelli in legno

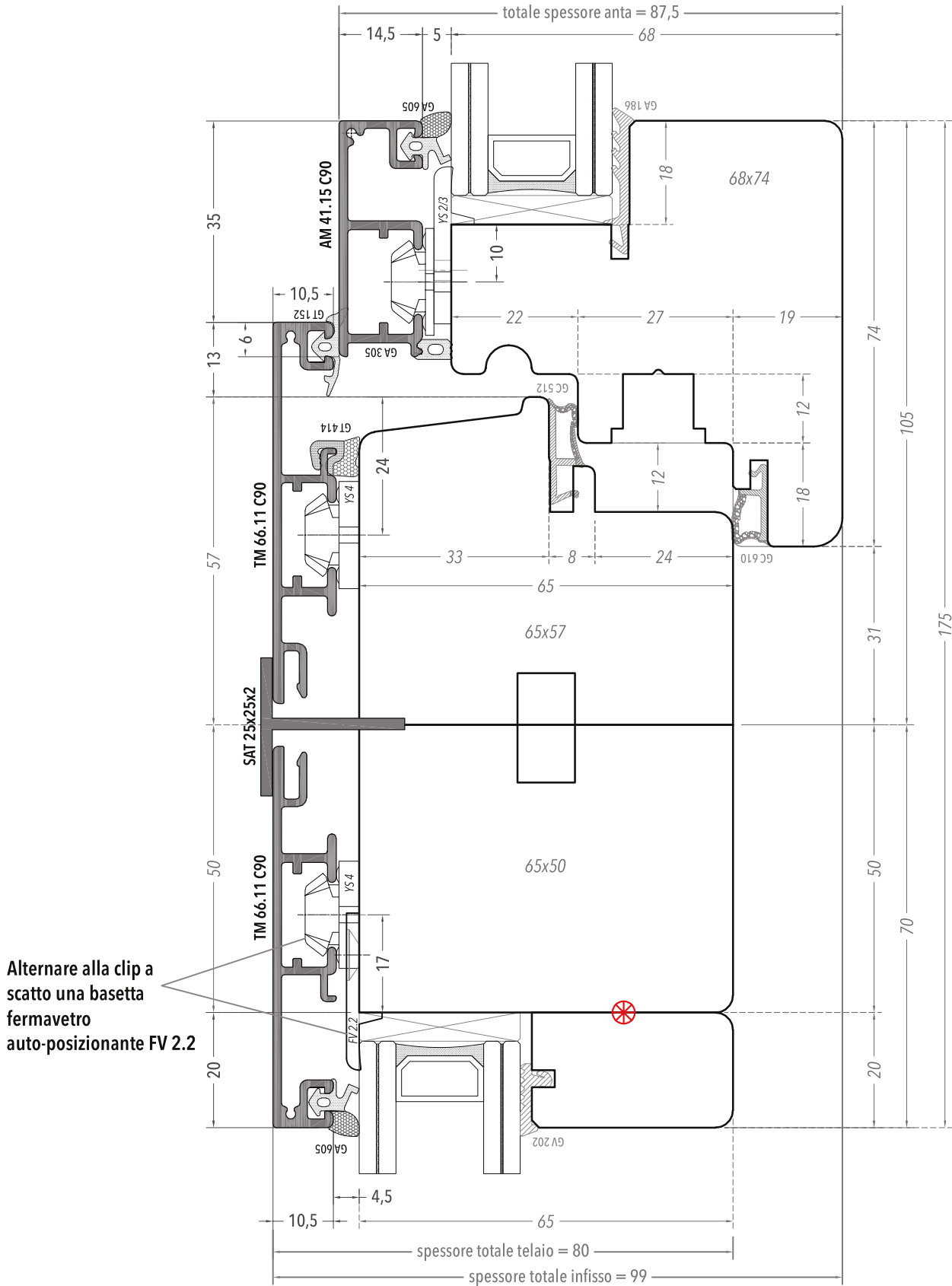

Soluzione consigliata per abbinamenti di grandi dimensioni.



Spessore telaio 58  
Spessore anta 68



# Alumfast Easy

---

SLIM

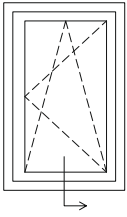

**FINESTRA**

SEZIONE VERTICALE  
 NODO INFERIORE  
 SCALA 1:1

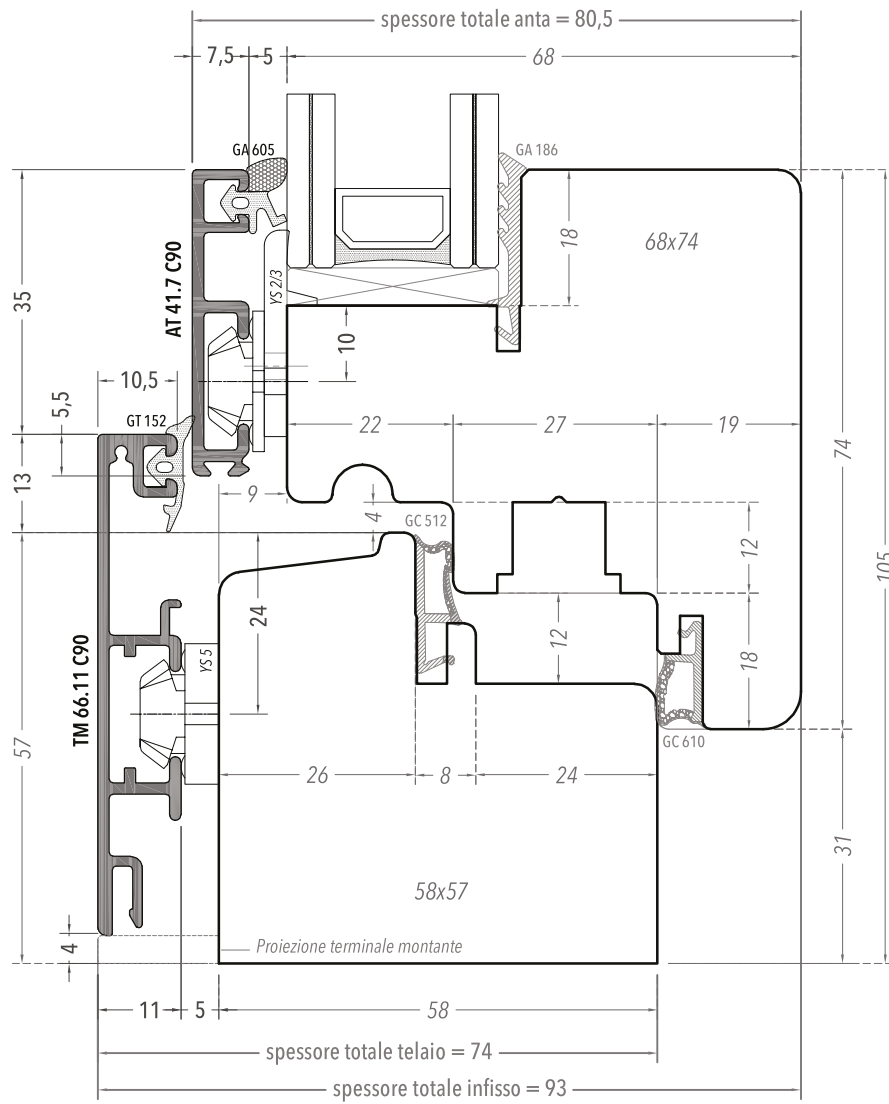

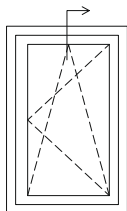

**FINESTRA**

SEZIONE VERTICALE  
NODO SUPERIORE  
SCALA 1:1

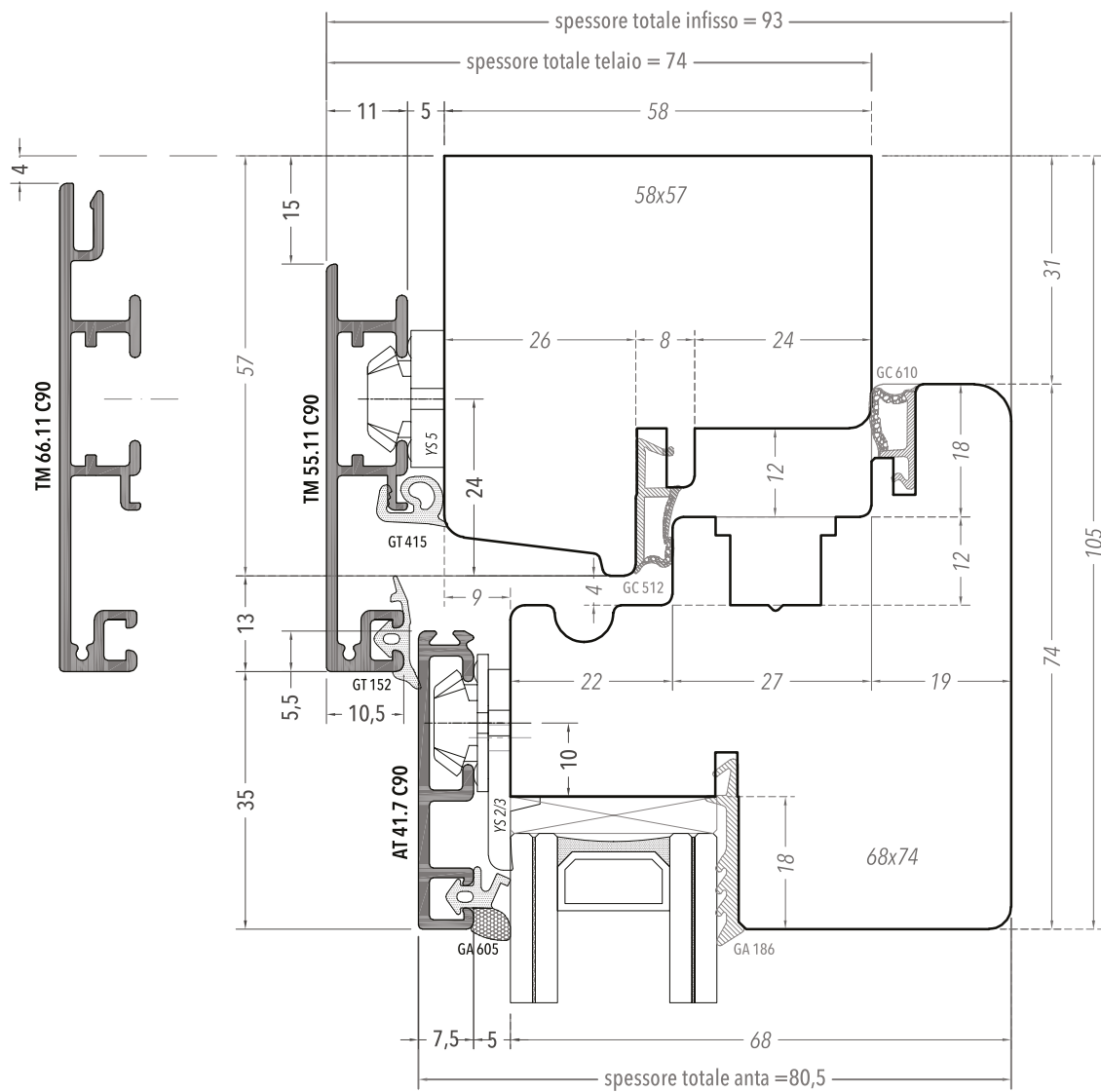

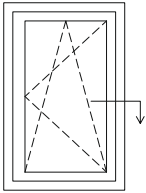

**FINESTRA**

SEZIONE ORIZZONTALE  
NODO LATERALE  
SCALA 1:1

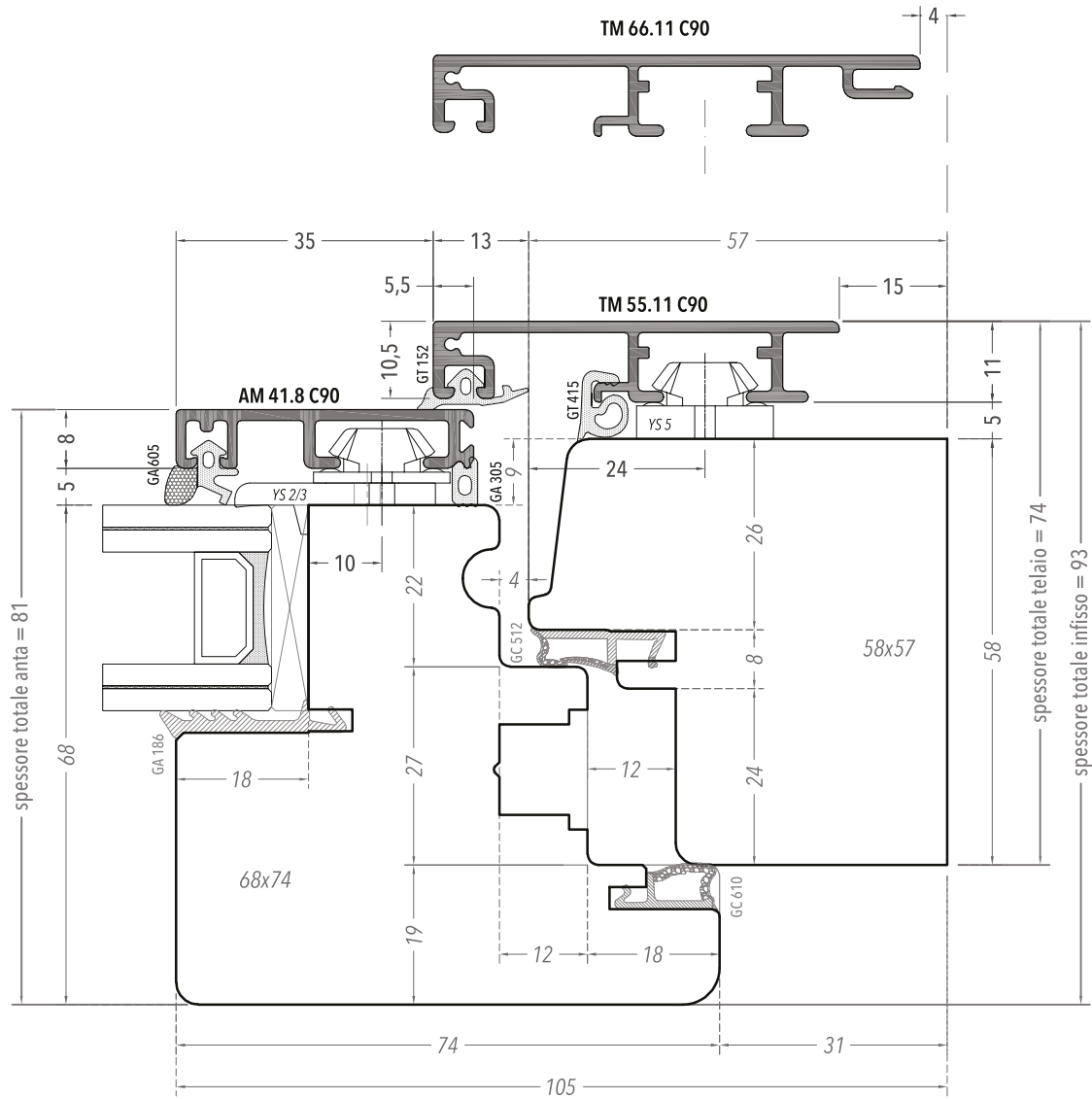

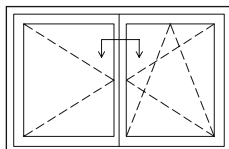

**FINESTRA**

SEZIONE ORIZZONTALE  
 NODO CENTRALE  
 SCALA 1:1

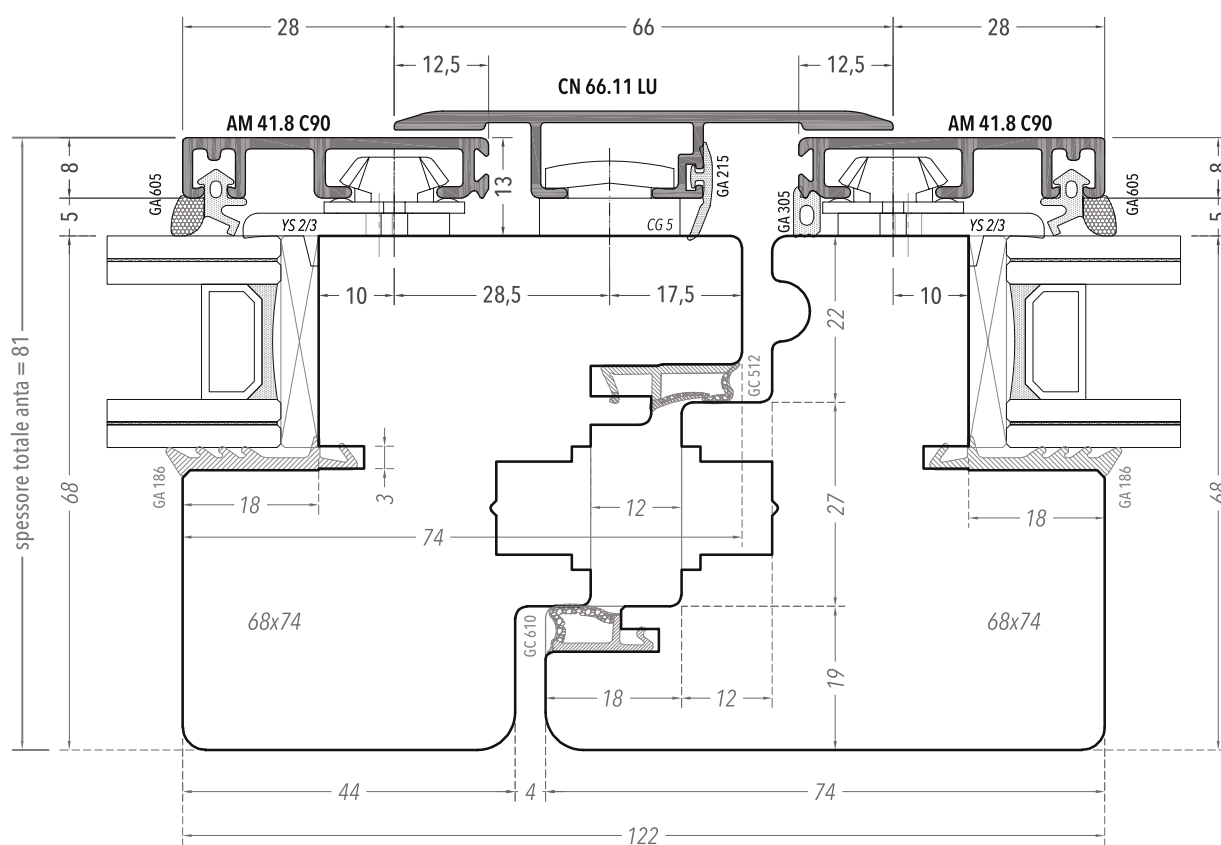

Per il disegno del nodo con montantino aggiunto consulta la pagina successiva.

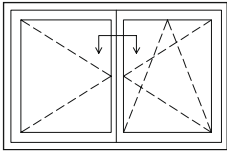

**FINESTRA**

SEZIONE ORIZZONTALE  
 NODO CENTRALE CON MONTANTINO AGGIUNTO  
 SCALA 1:1

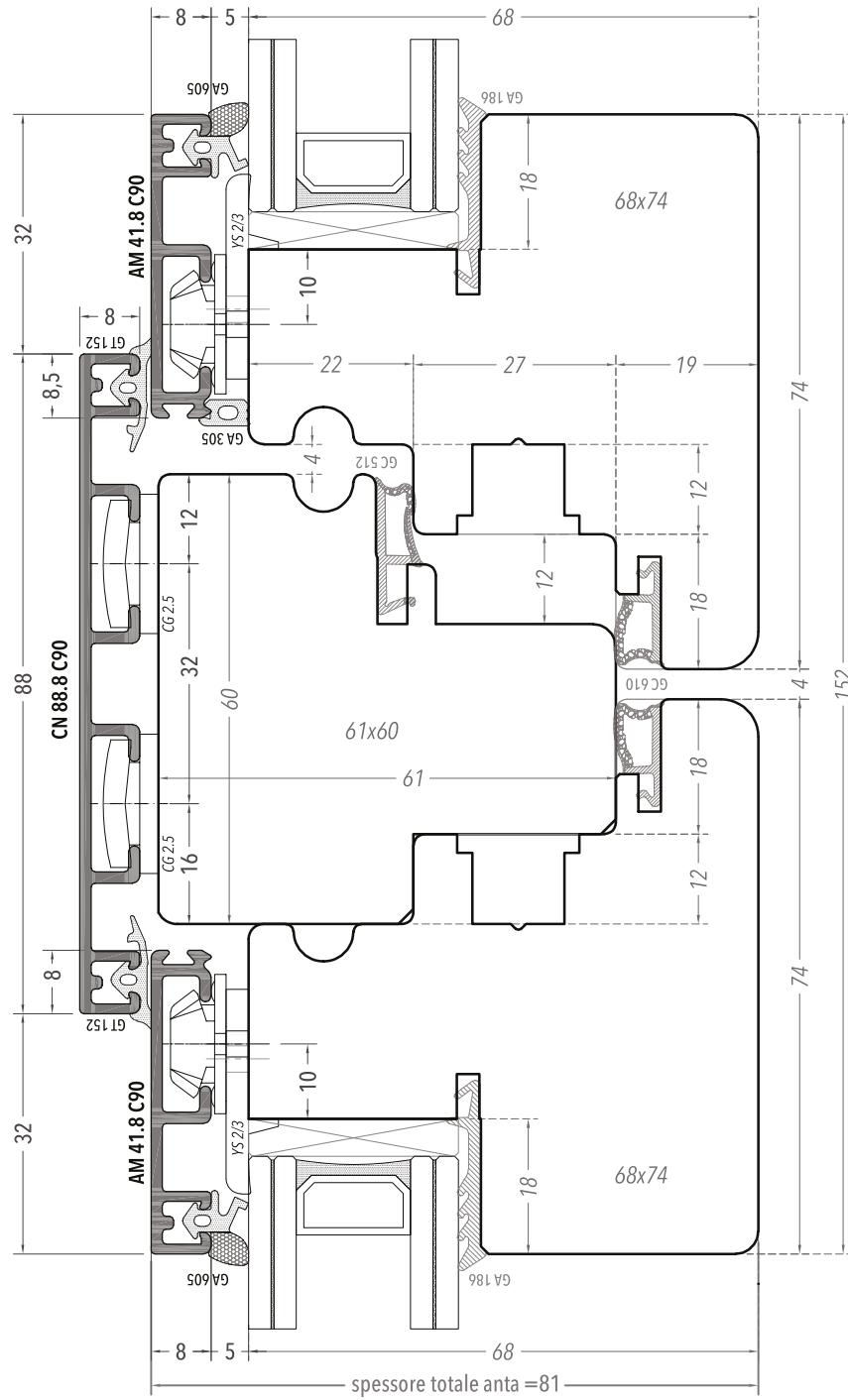

**PORTAFINESTRA**

SEZIONE VERTICALE  
NODO INFERIORE  
SCALA 1:1

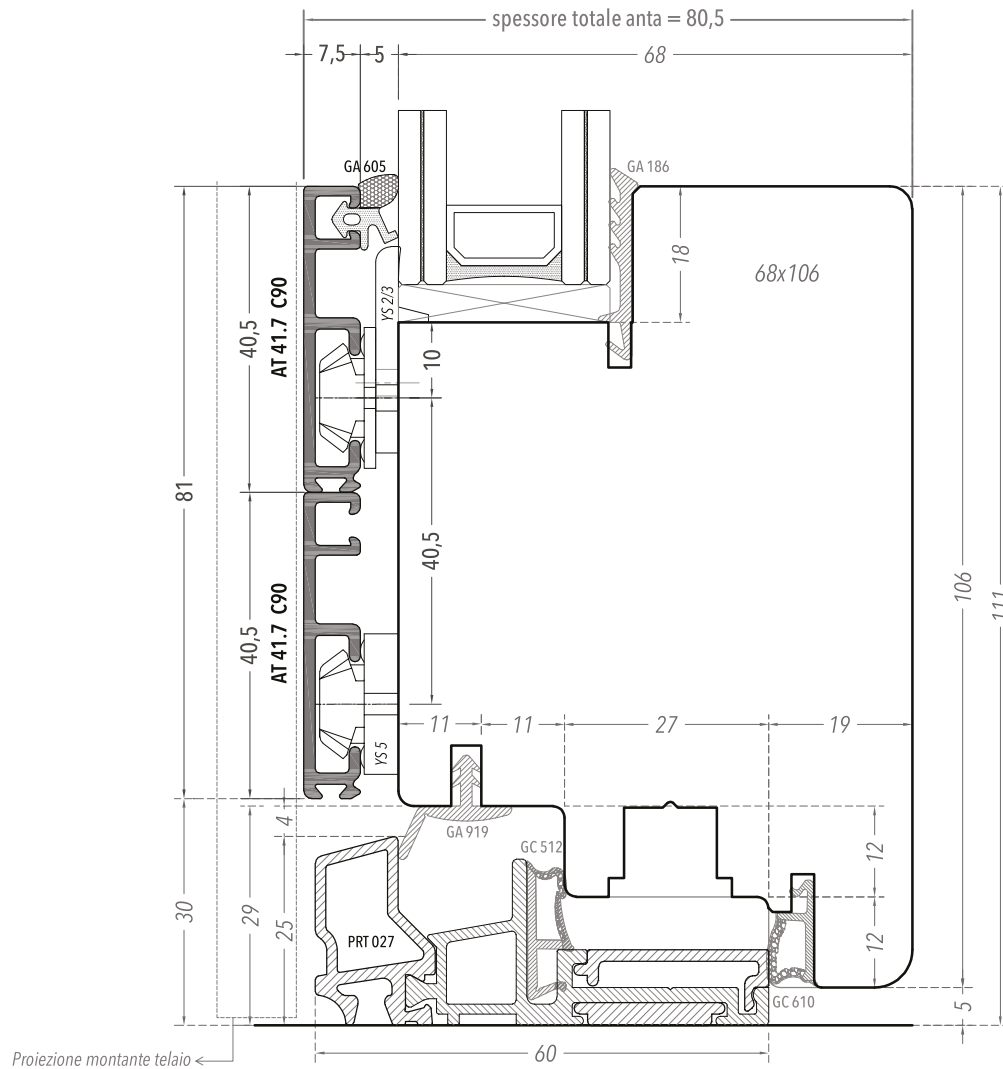
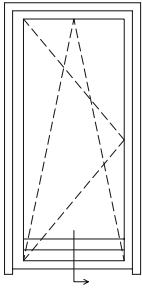

Per tutte le altre combinazioni di profili per gli zoccoli della portafinestra, consulta le pagine introduttive del catalogo.

**PORTAFINESTRA CON SERRATURA PASSANTE**

SEZIONE ORIZZONTALE  
 NODO LATERALE  
 SCALA 1:1

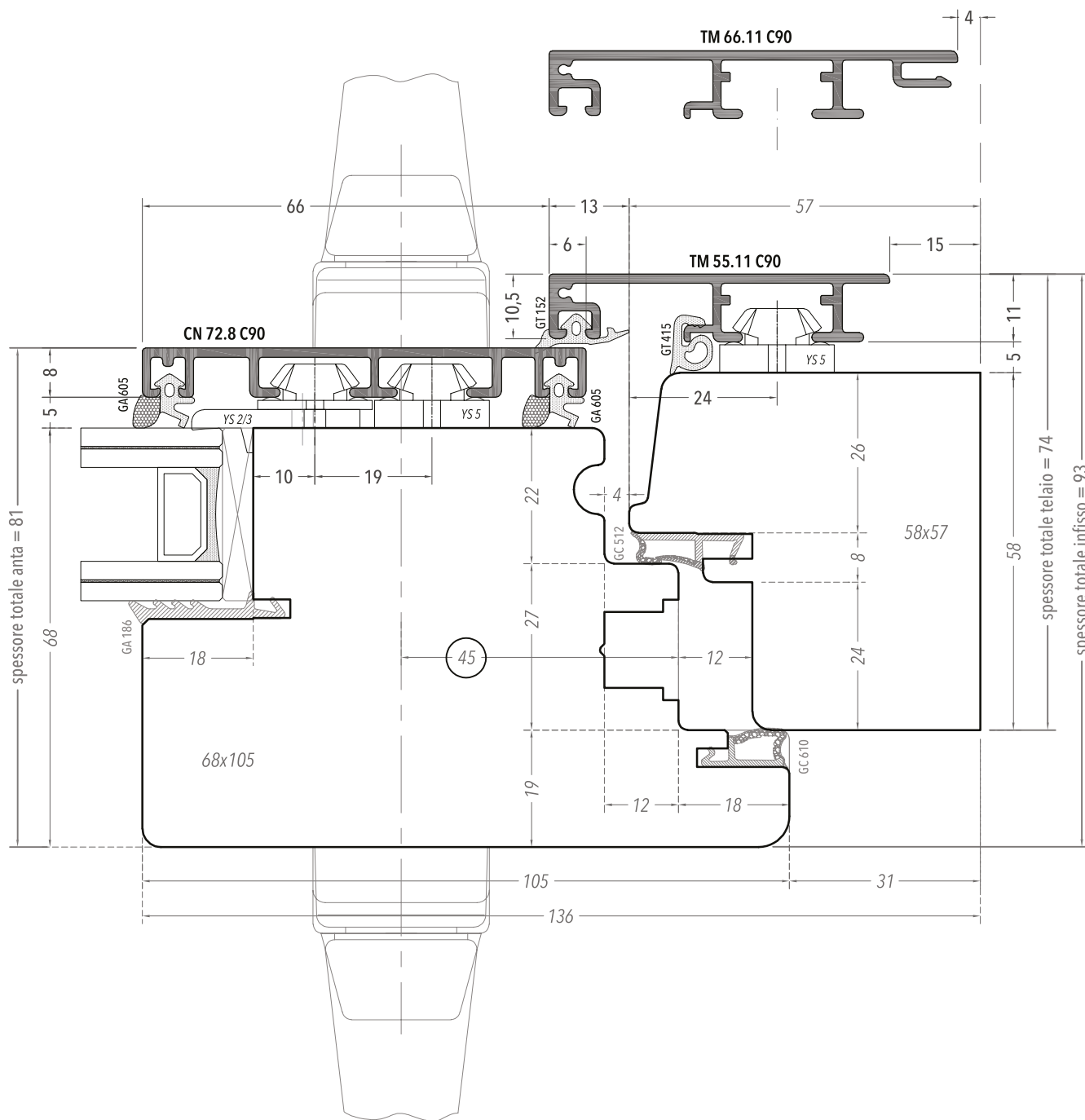
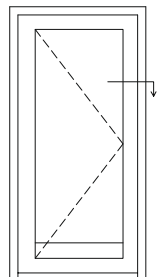

In caso di serratura passante, è possibile maggiorare solo il montante con la maniglia e lasciare invariata la sezione anta sugli altri lati.  
 Entrata consigliata per la serratura: 45 mm.





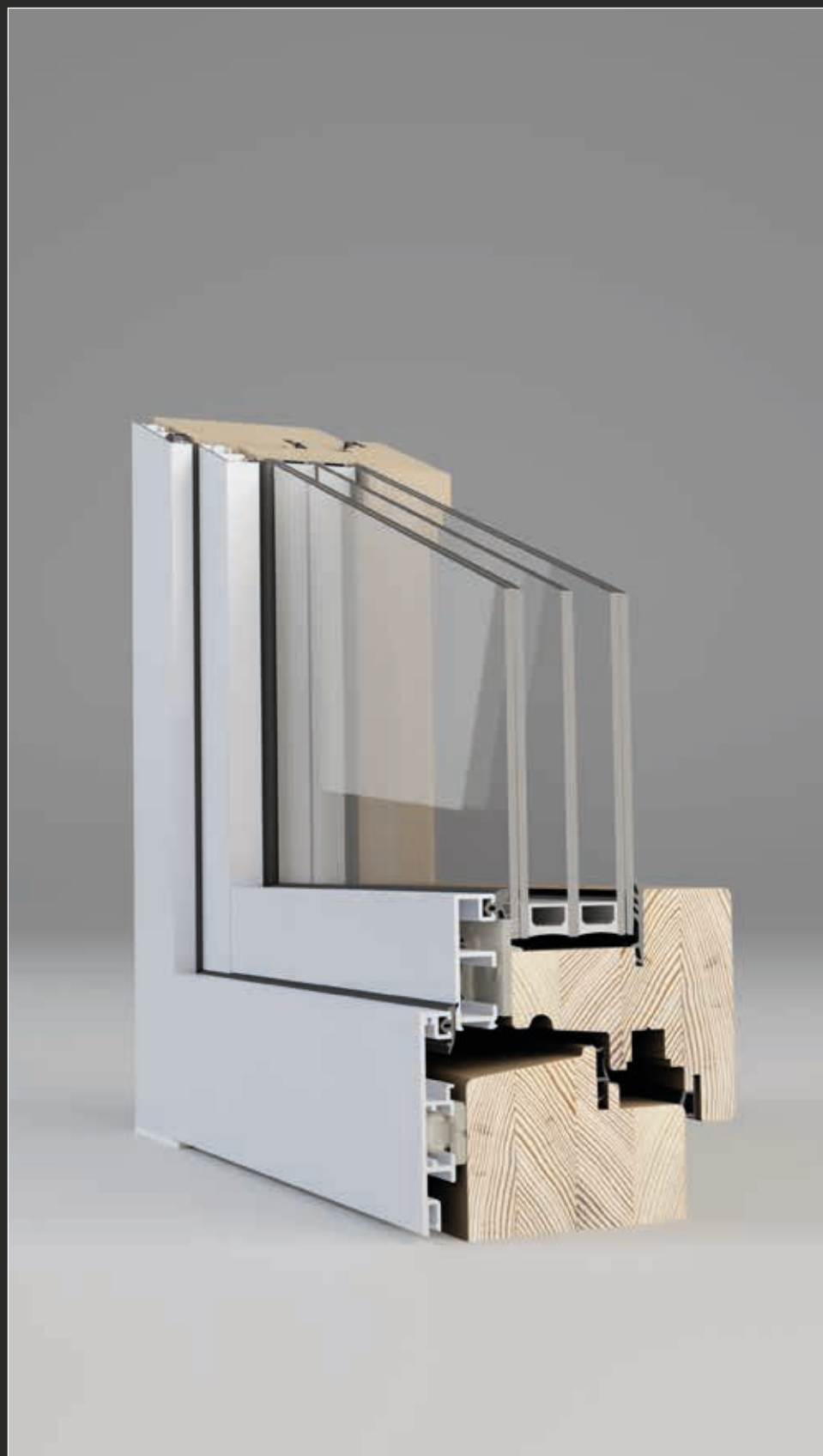

Spessore telaio 77  
Spessore anta 80

# Alumfast Easy

---

HP80

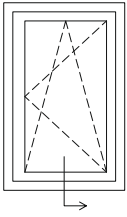

**FINESTRA**

SEZIONE VERTICALE  
NODO INFERIORE  
SCALA 1:1

Variante traverso  
inferiore con profilo  
Slide inclinato 15°

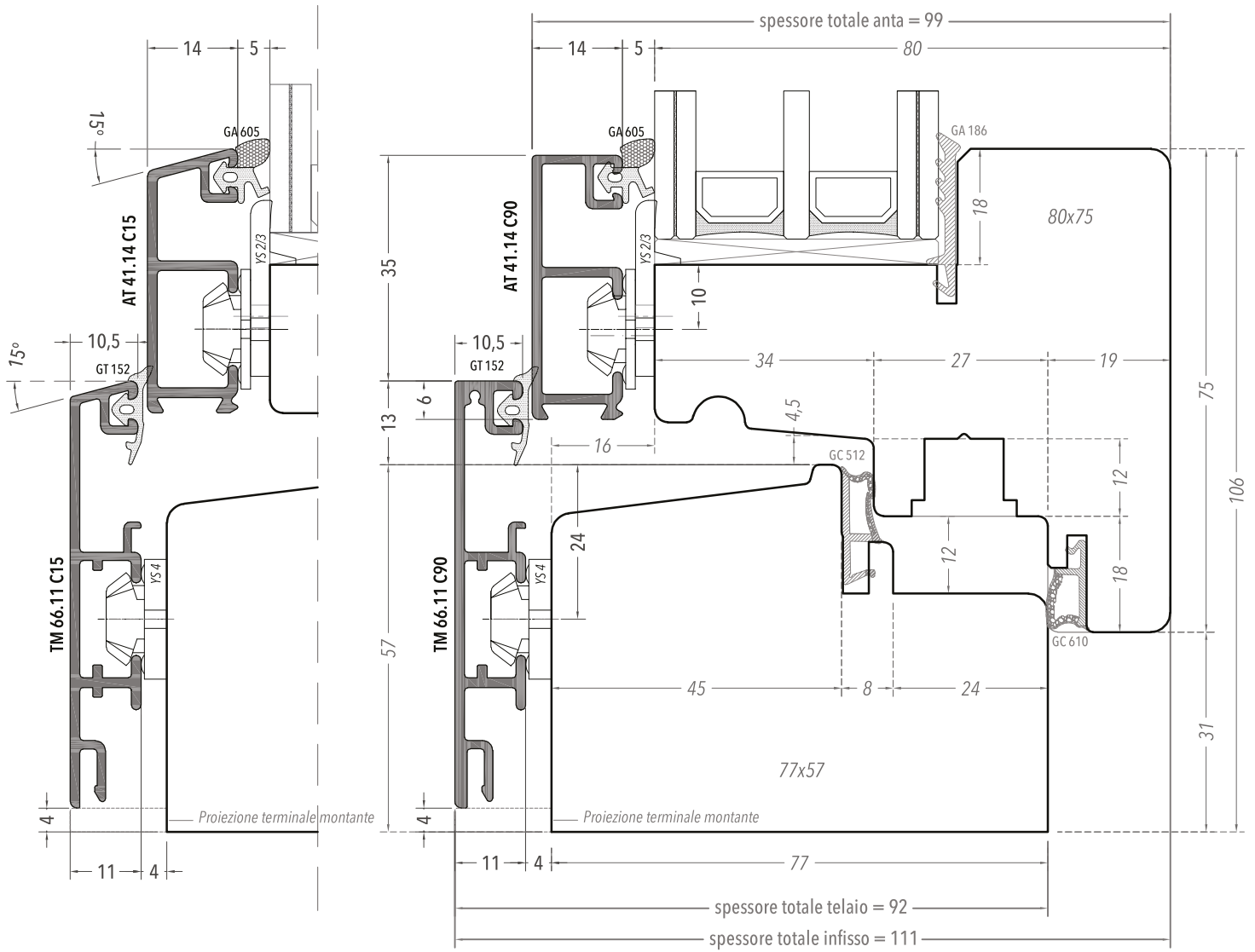

# FINESTRA

SEZIONE ORIZZONTALE  
NODO LATERALE  
SCALA 1:1

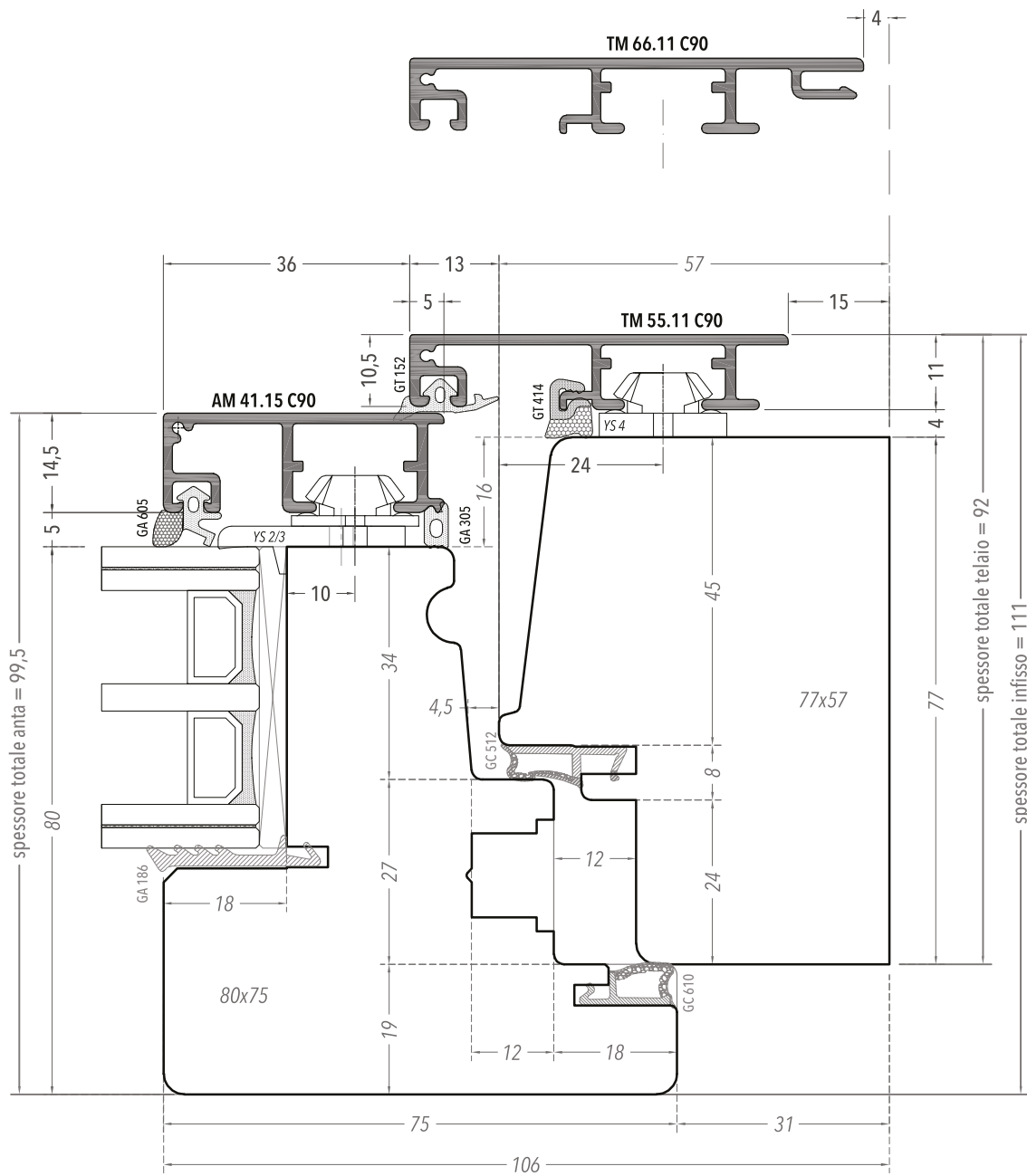
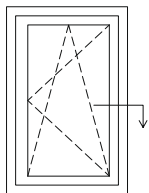

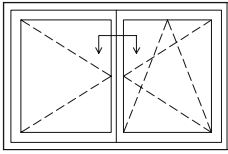

**FINESTRA**

SEZIONE ORIZZONTALE  
 NODO CENTRALE  
 SCALA 1:1

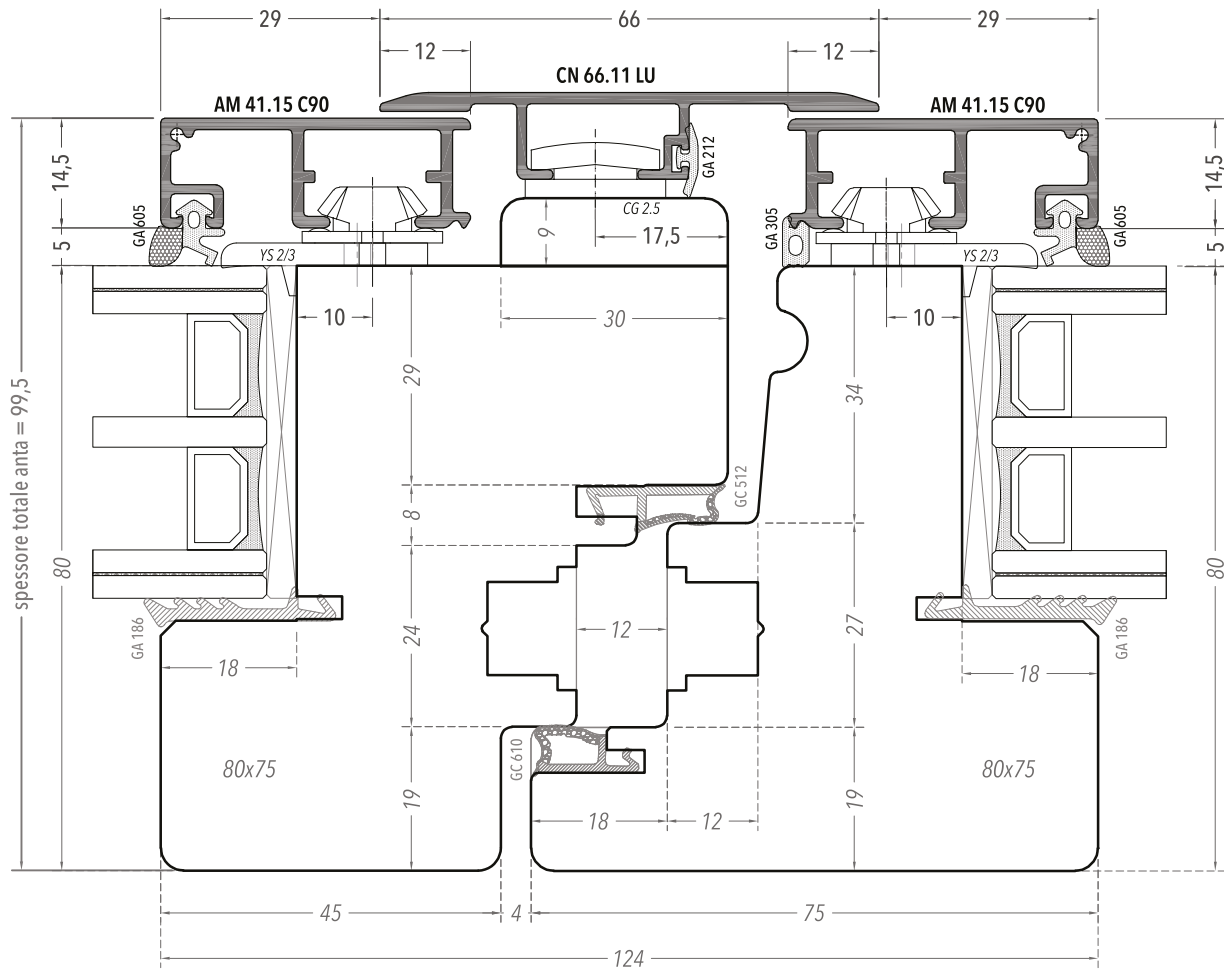

**PORTAFINESTRA**

SEZIONE VERTICALE  
NODO INFERIORE  
SCALA 1:1

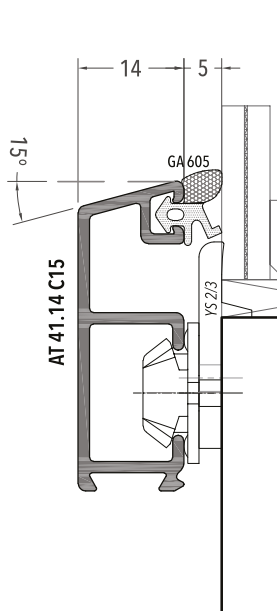
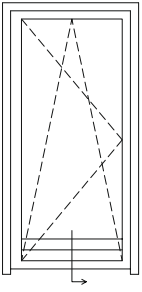

Variante con profilo  
Slide inclinato a 15° su  
traverso inferiore anta

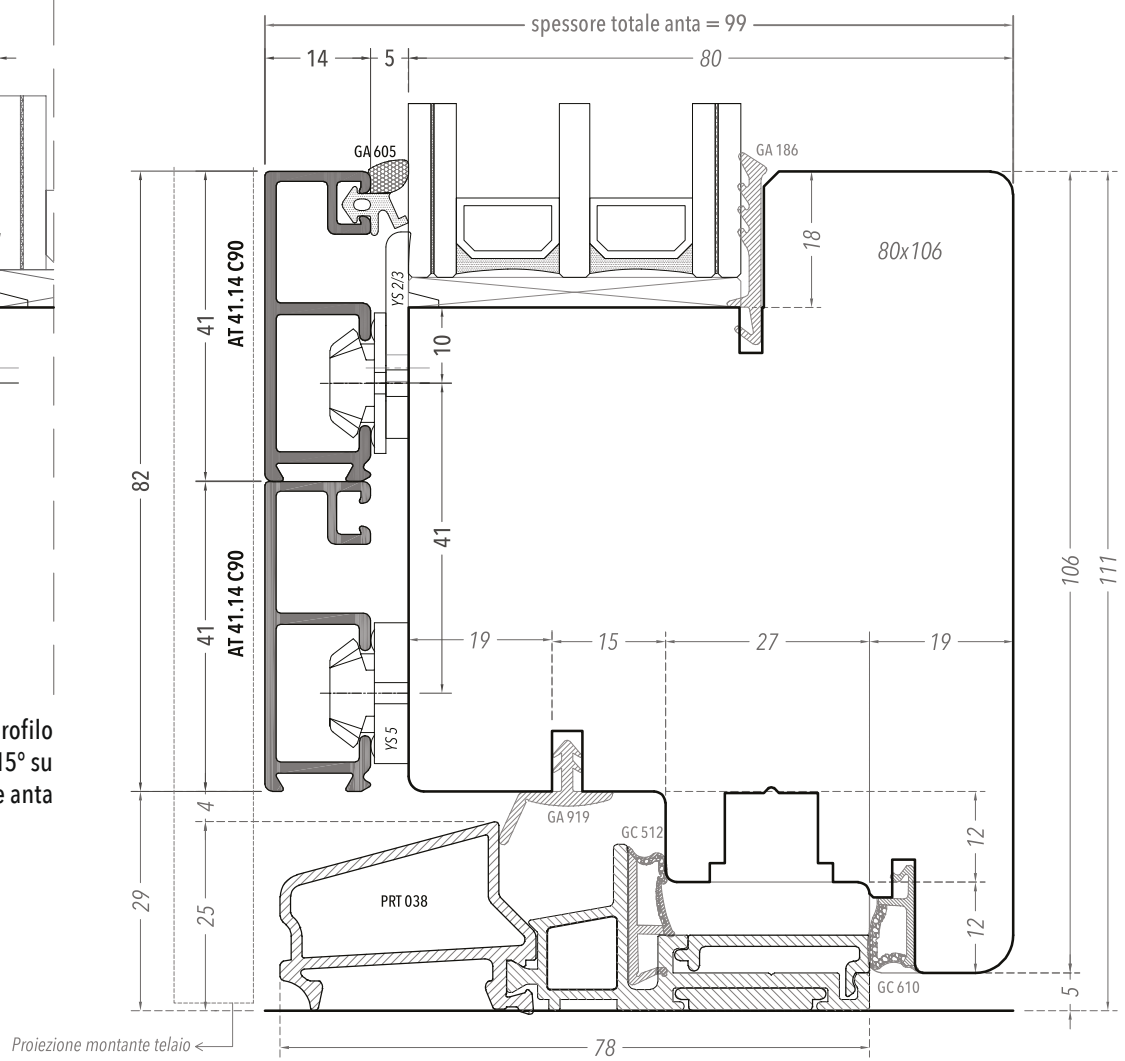

Per tutte le altre combinazioni di profili per gli zoccoli della portafinestra, consulta le pagine introduttive del catalogo.



Spessore telaio 58  
Spessore anta 68



# Alumfast Grace

---

STANDARD

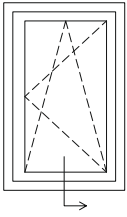

**FINESTRA**

SEZIONE VERTICALE  
 NODO INFERIORE  
 SCALA 1:1

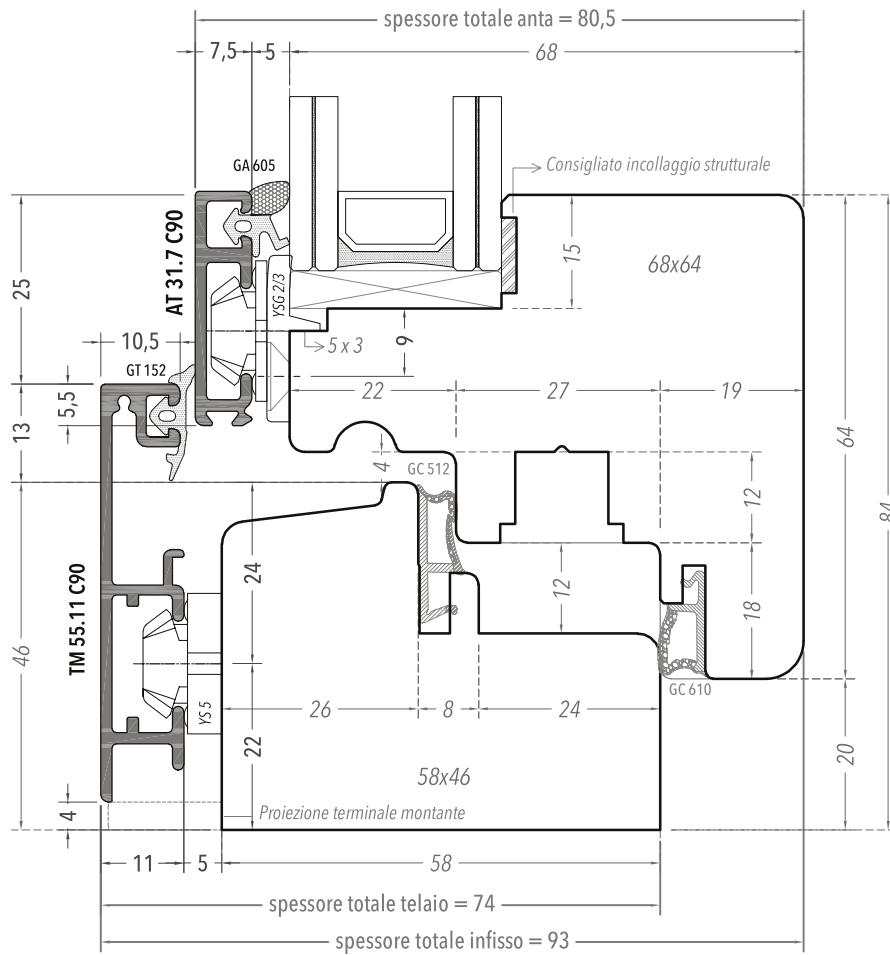

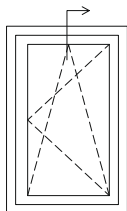

**FINESTRA**

SEZIONE VERTICALE  
 NODO SUPERIORE  
 SCALA 1:1

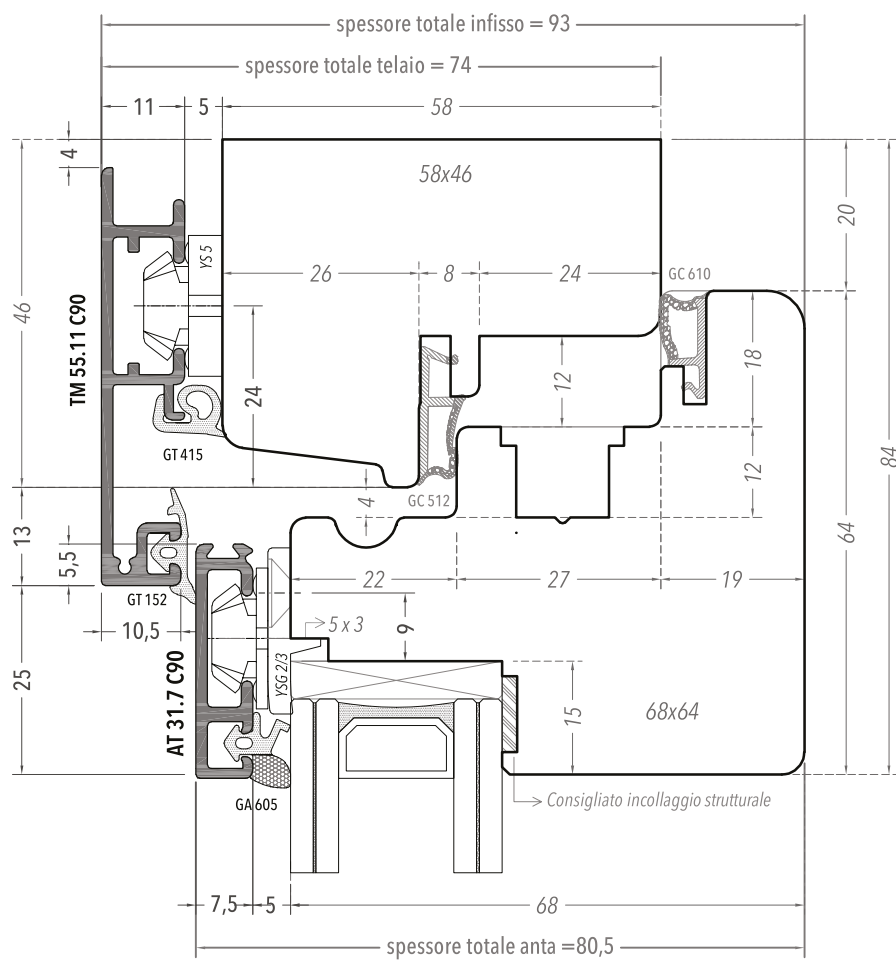

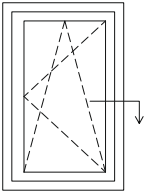

**FINESTRA**

SEZIONE ORIZZONTALE  
 NODO LATERALE  
 SCALA 1:1

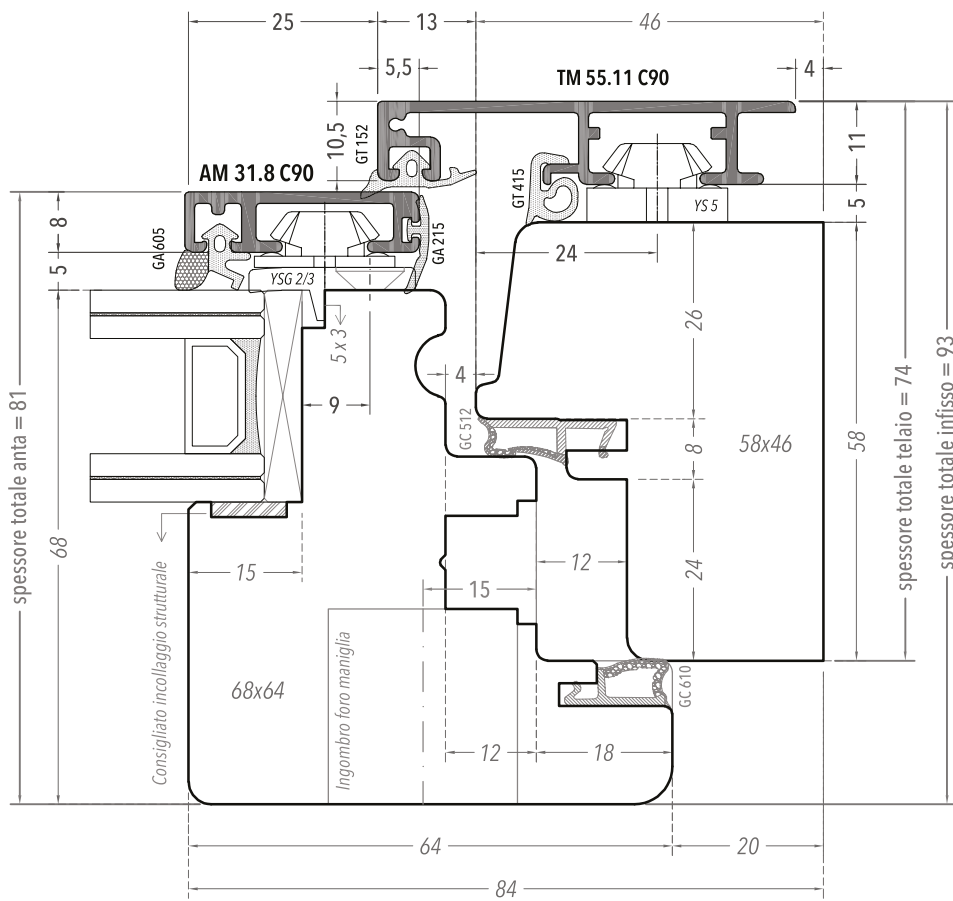

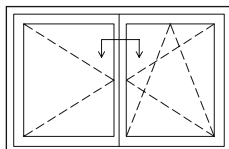

# FINESTRA

SEZIONE ORIZZONTALE  
NODO CENTRALE  
SCALA 1:1

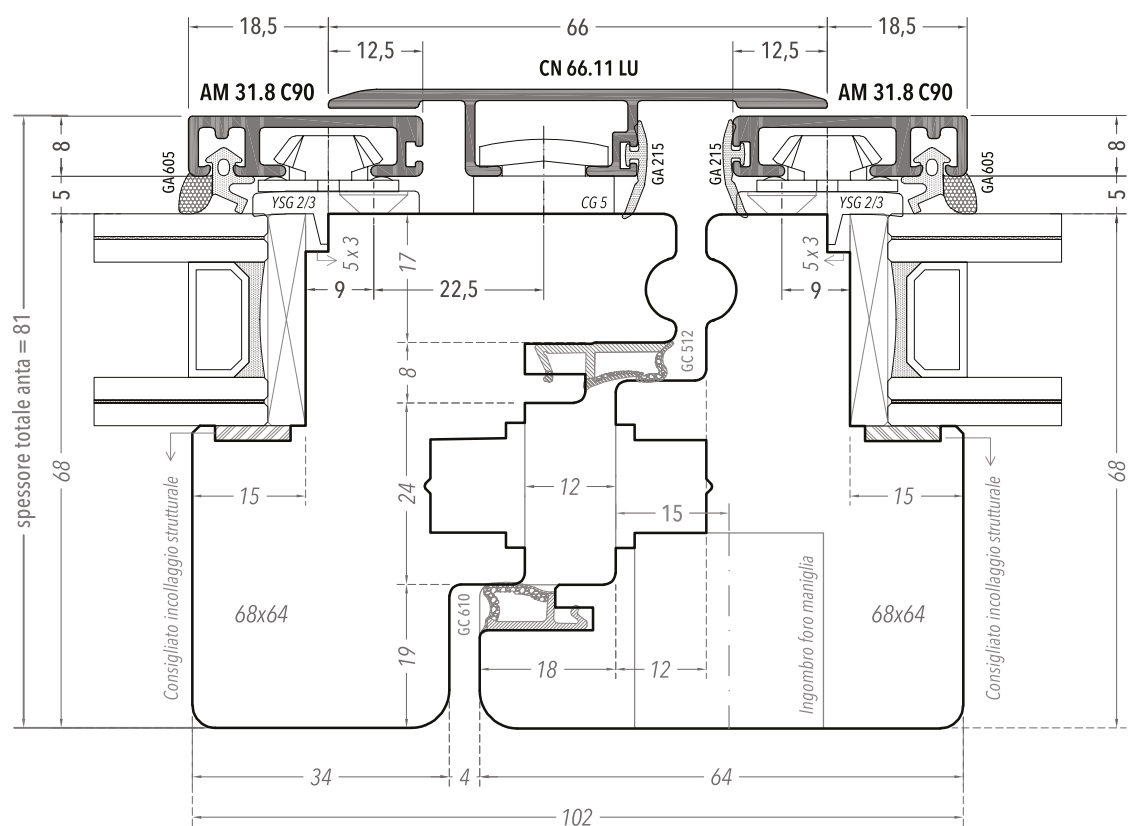

Per il disegno del nodo con montantino aggiunto consulta la pagina successiva.

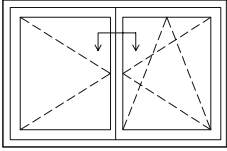

**FINESTRA**

SEZIONE ORIZZONTALE  
 NODO CENTRALE CON MONTANTINO AGGIUNTO  
 SCALA 1:1

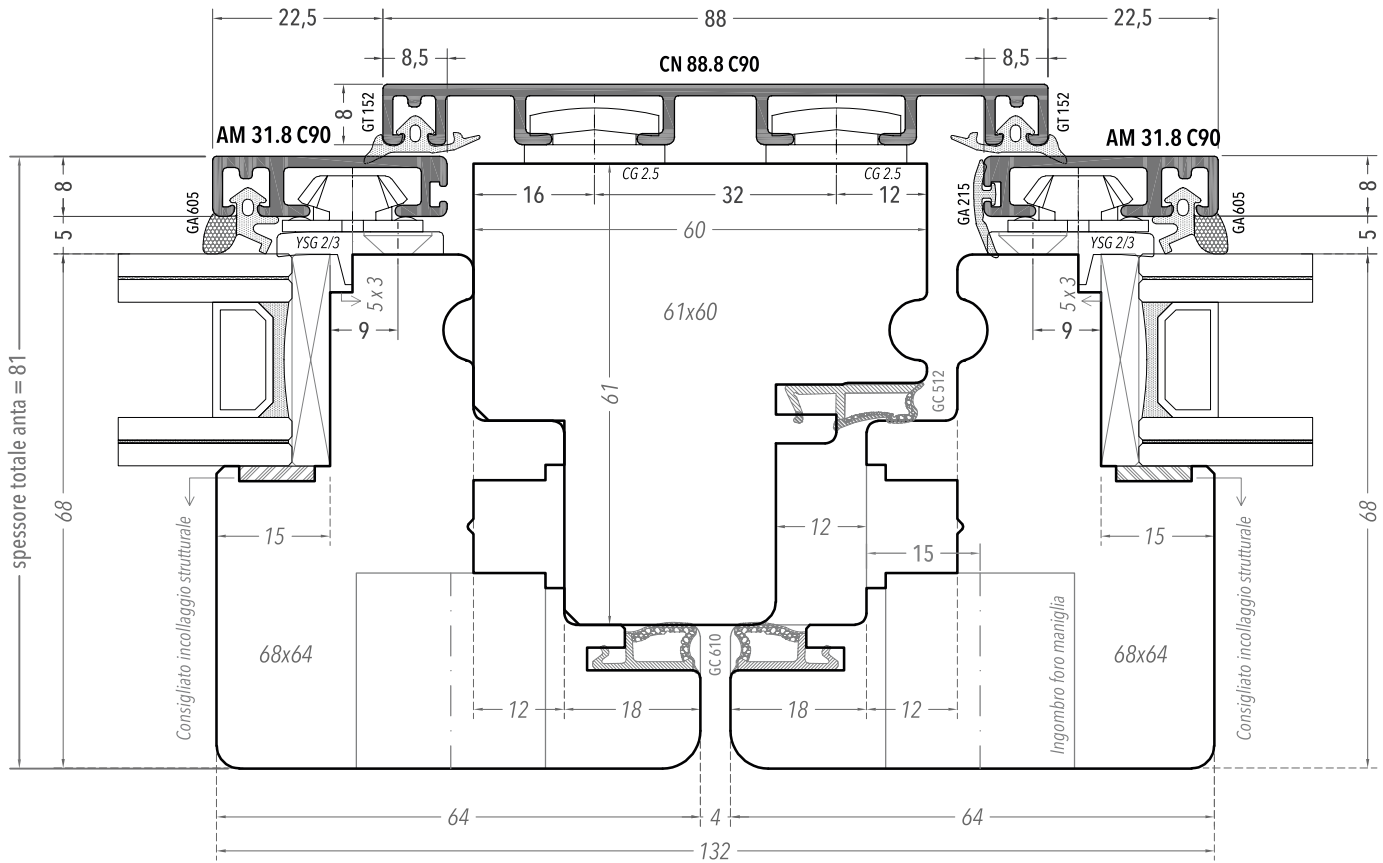

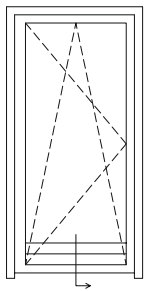

**PORTAFINESTRA**  
 SEZIONE VERTICALE  
 NODO INFERIORE  
 SCALA 1:1

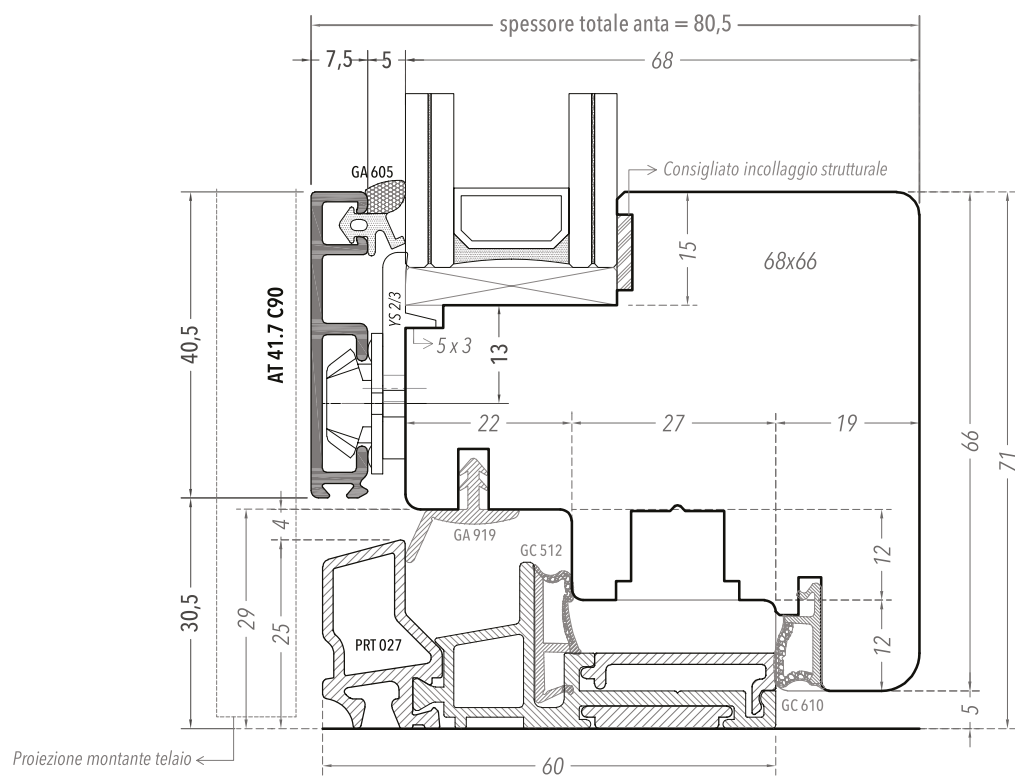



Spessore telaio 68  
Spessore anta 80



# Alumfast Grace

---

HP80

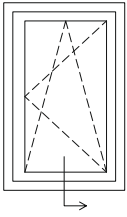

**FINESTRA**

SEZIONE VERTICALE  
 NODO INFERIORE  
 SCALA 1:1

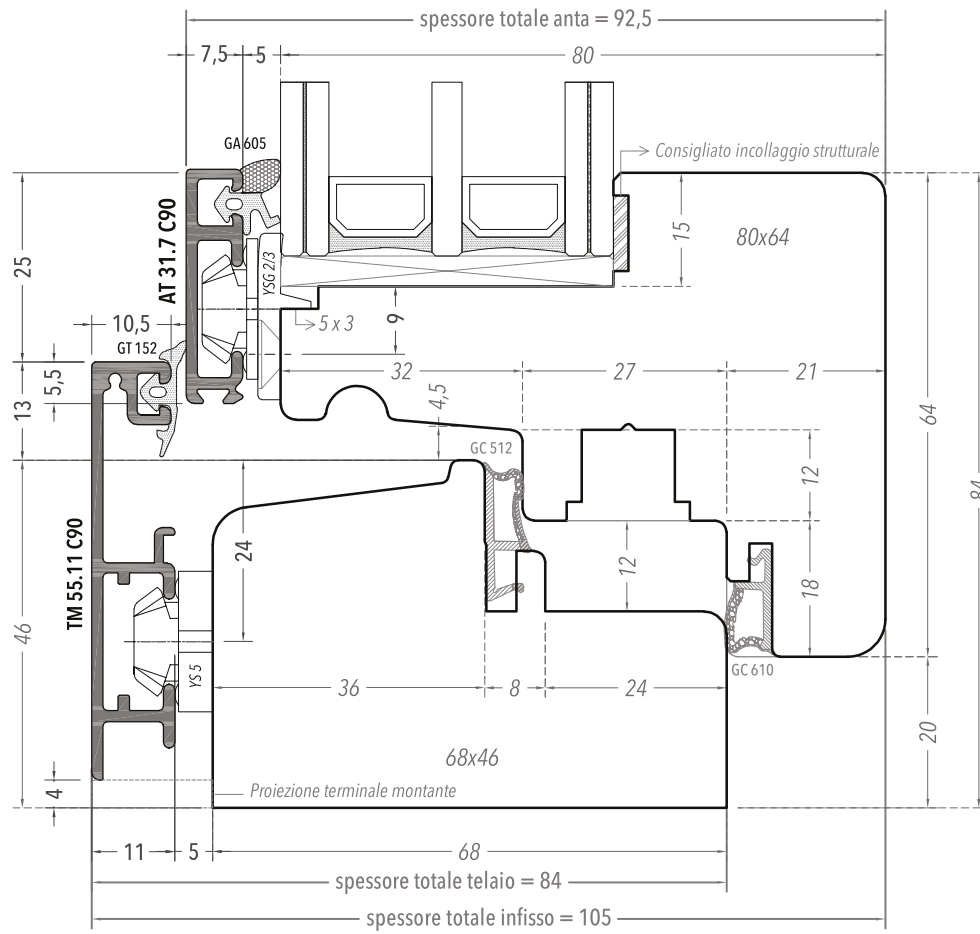

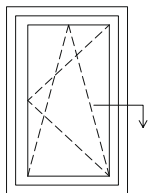

**FINESTRA**  
 SEZIONE ORIZZONTALE  
 NODO LATERALE  
 SCALA 1:1

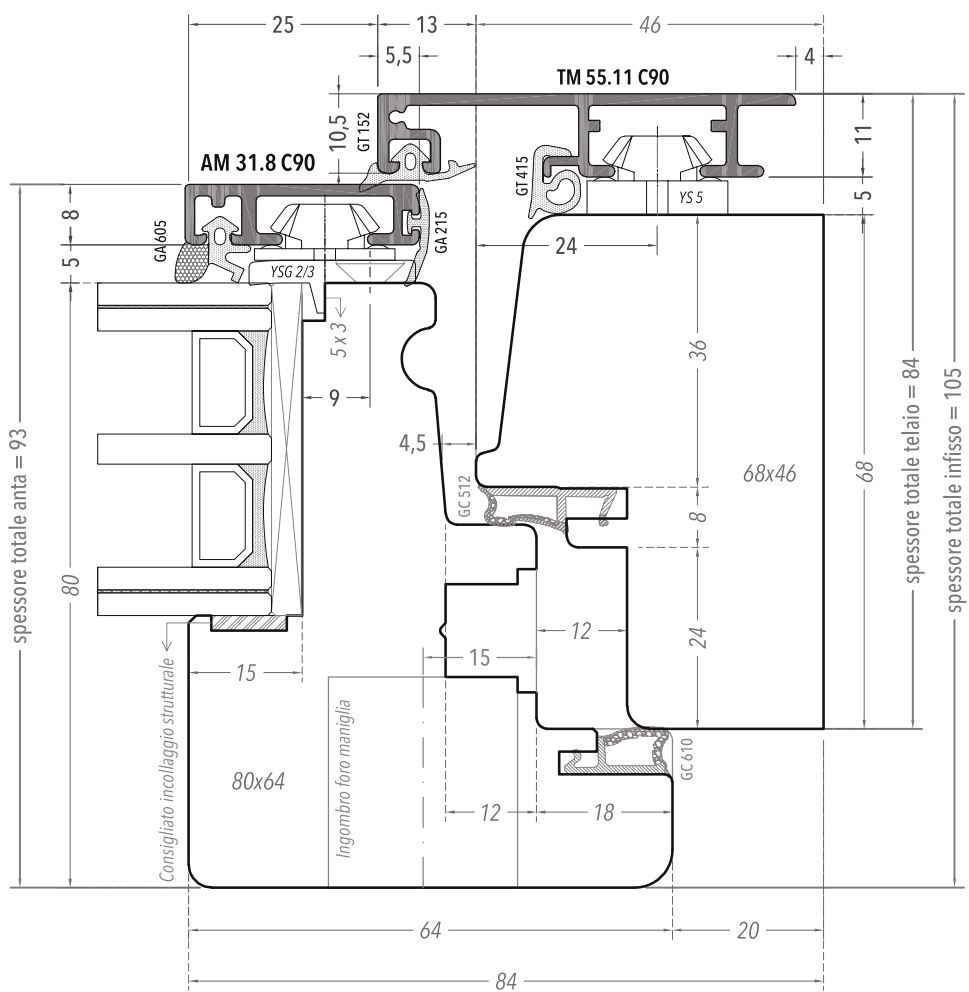

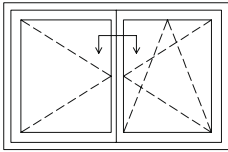

**FINESTRA**

SEZIONE ORIZZONTALE  
NODO CENTRALE  
SCALA 1:1

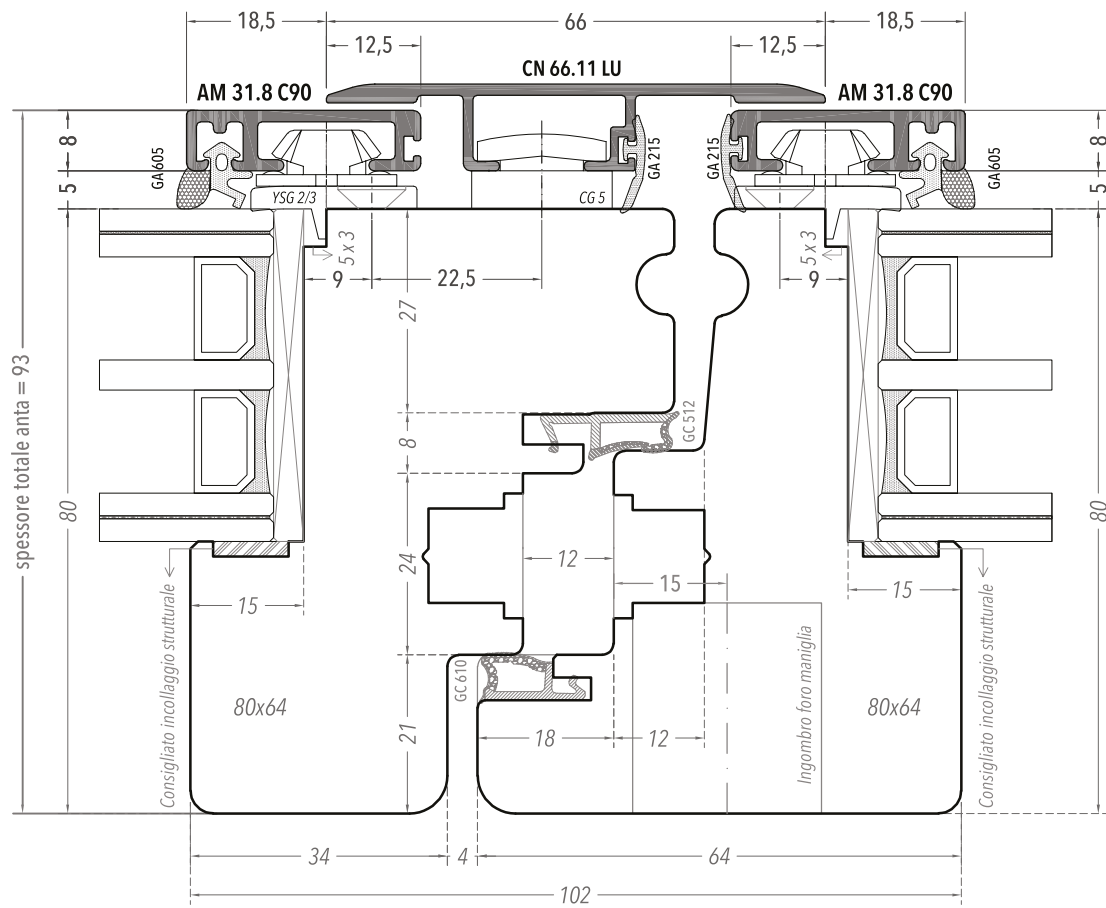

Per il disegno del nodo con montantino aggiunto, consulta la pagina del montantino Easy Slim.

**PORTAFINESTRA**

SEZIONE VERTICALE  
NODO INFERIORE  
SCALA 1:1

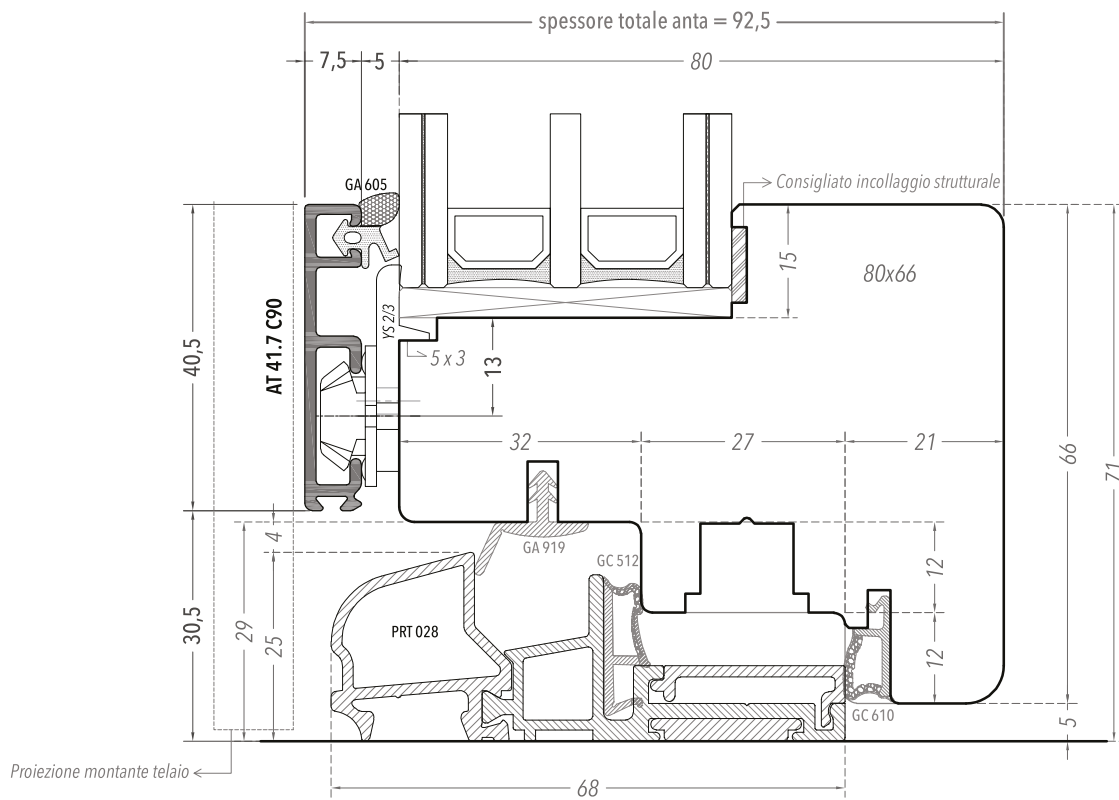
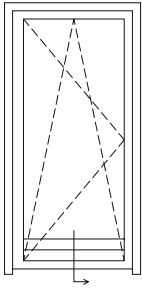

Per tutte le altre combinazioni di profili per gli zoccoli della portafinestra, consulta le pagine introduttive del catalogo.



Spessore telaio 102  
Spessore anta 92

# Alumfast Canvas

---

STANDARD

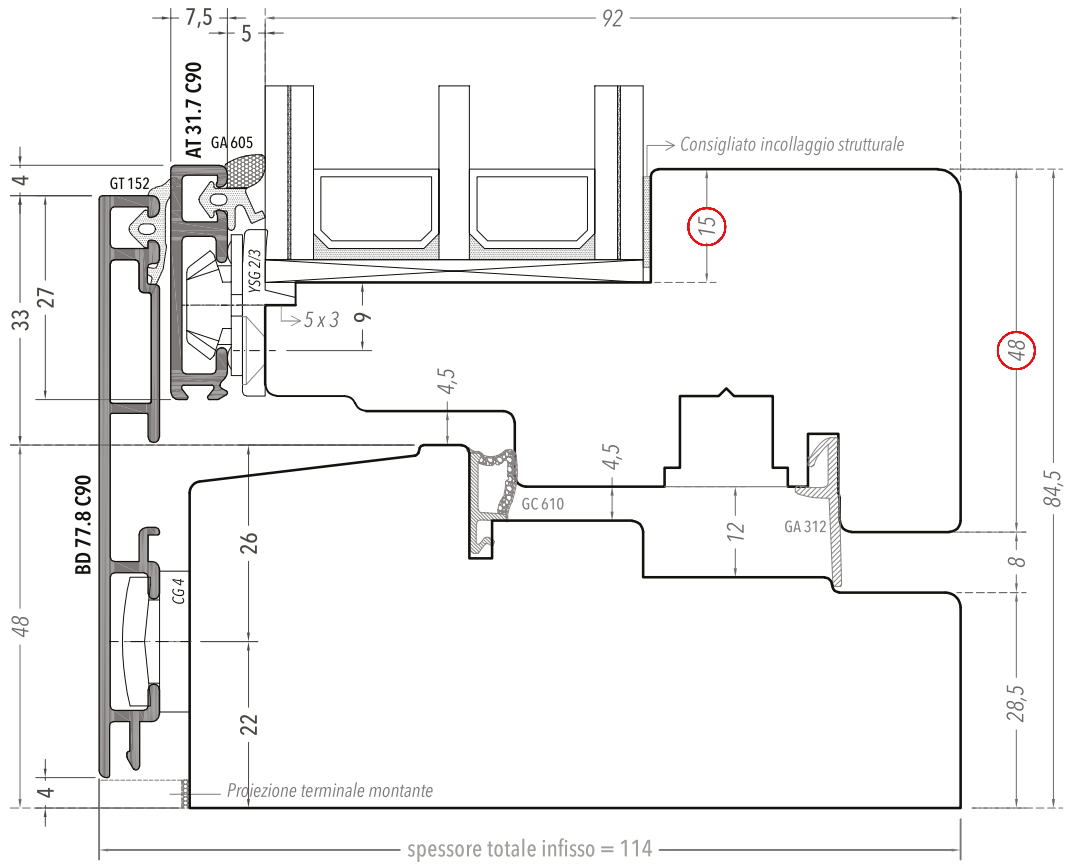

Soluzione alternativa con battuta interna vetro da 18

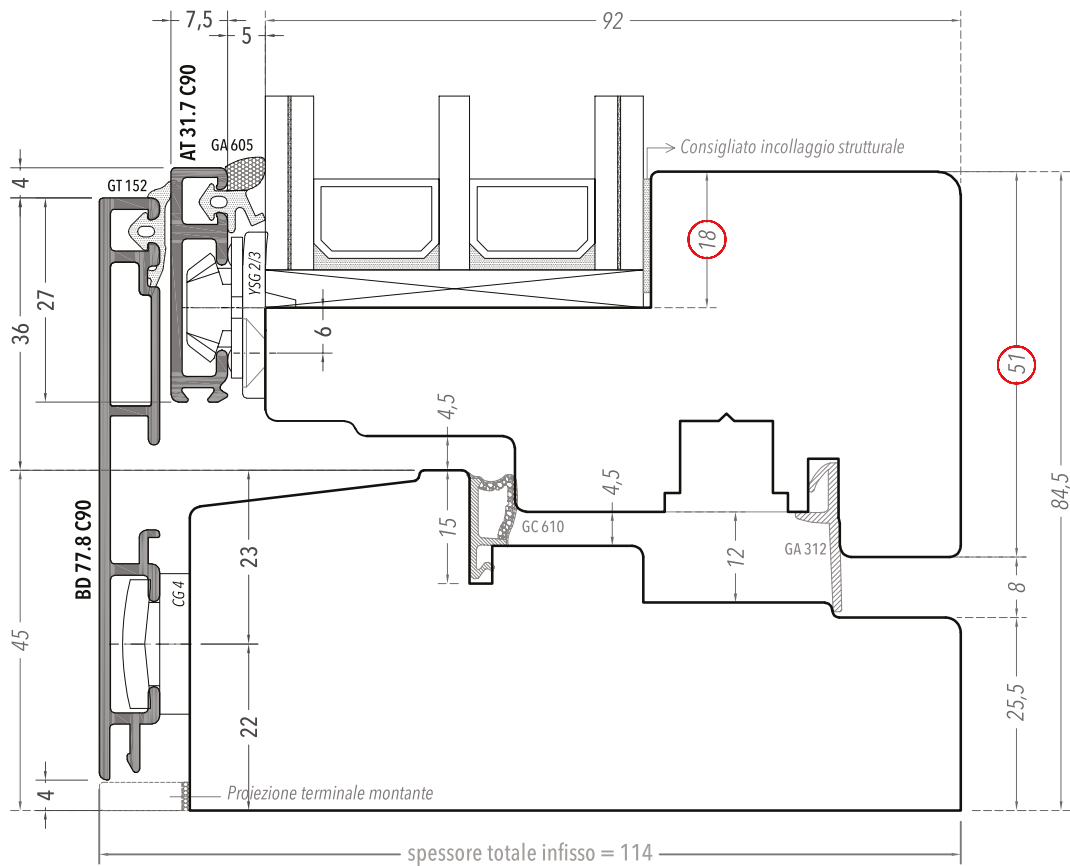

Varianti fermavetro valido per tutti i sistemi Canvas.



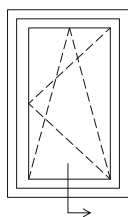

**SOLUZIONE  
SPESSORE  
ANTA 80**

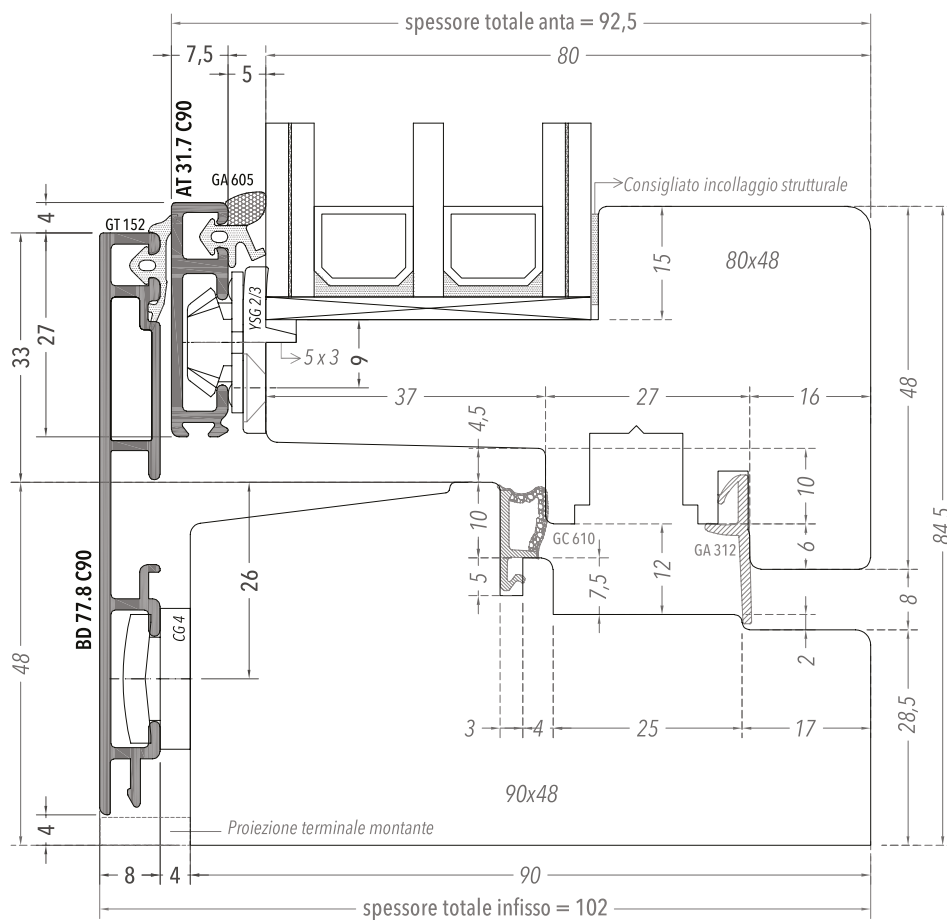

**SOLUZIONE  
SPESSORE  
ANTA 80/92**

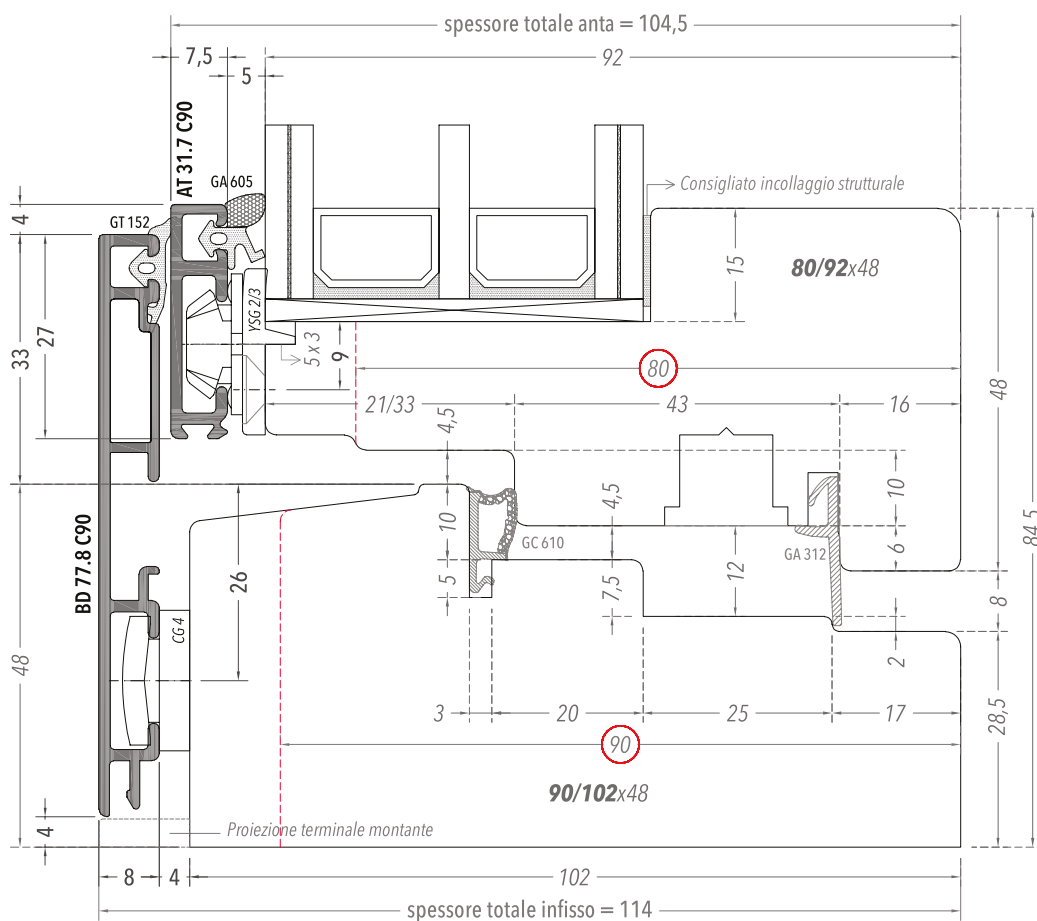

Varianti: telaio 90x48 e anta 80x48; telaio 102x48 e anta 92x48.

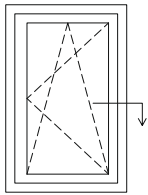

**SOLUZIONE  
SPESSORE  
ANTA 80**

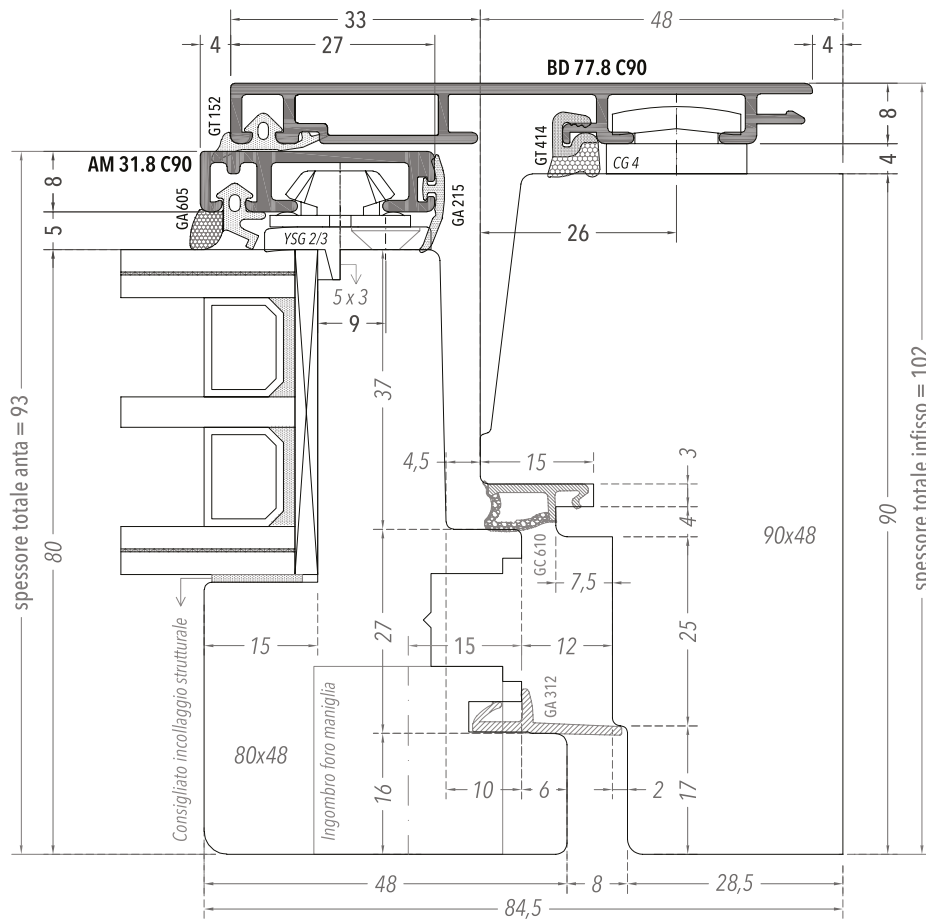

**FINESTRA**  
SEZIONE ORIZZONTALE  
NODO LATERALE  
SCALA 1:1

**SOLUZIONE  
SPESSORE  
ANTA 80/92**

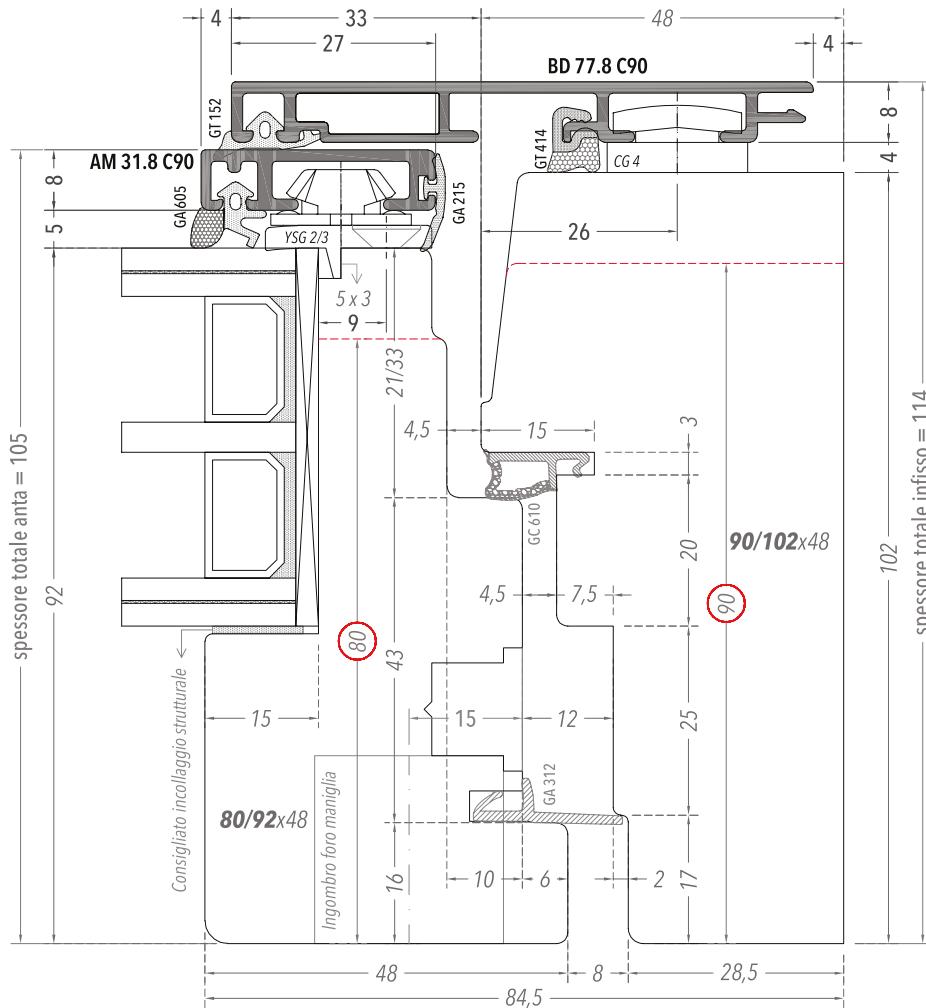

Varianti: telaio 90x48 e anta 80x48; telaio 102x48 e anta 92x48.

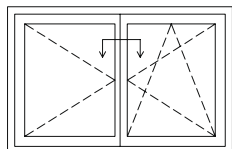

**SOLUZIONE  
SPESSORE  
ANTA 80**

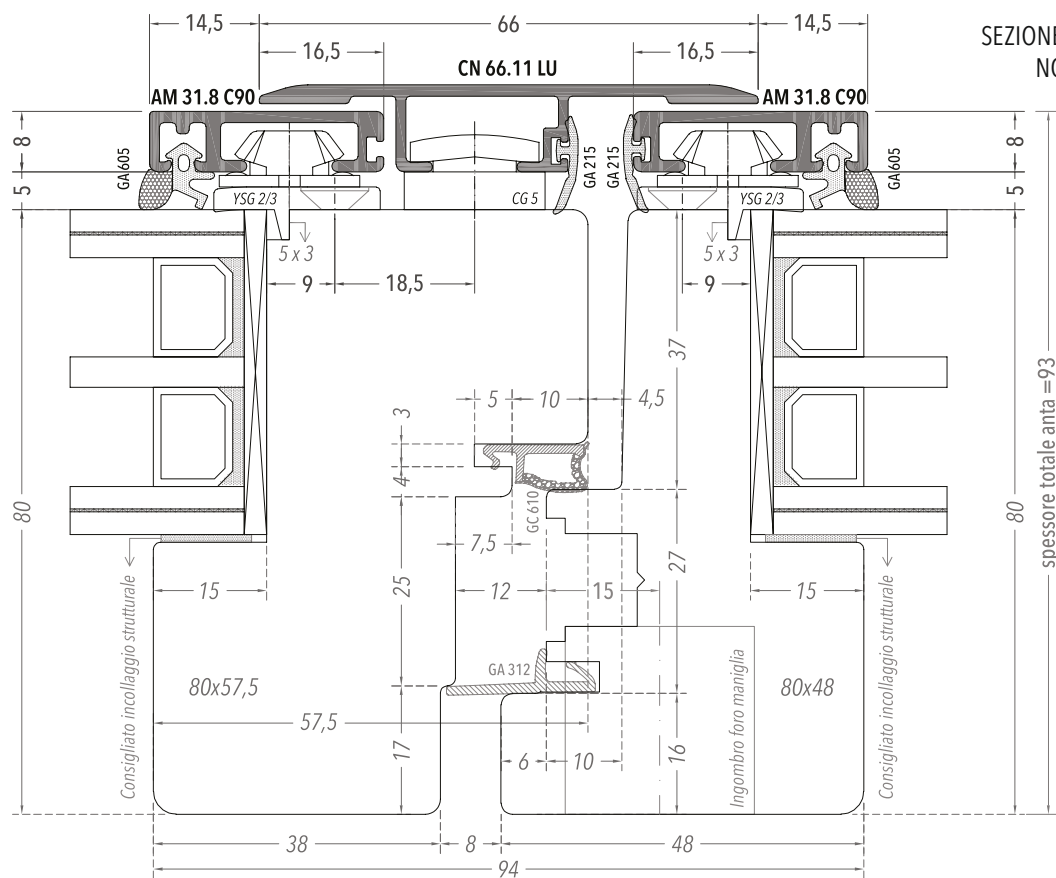

**SOLUZIONE  
SPESSORE  
ANTA 80/92**

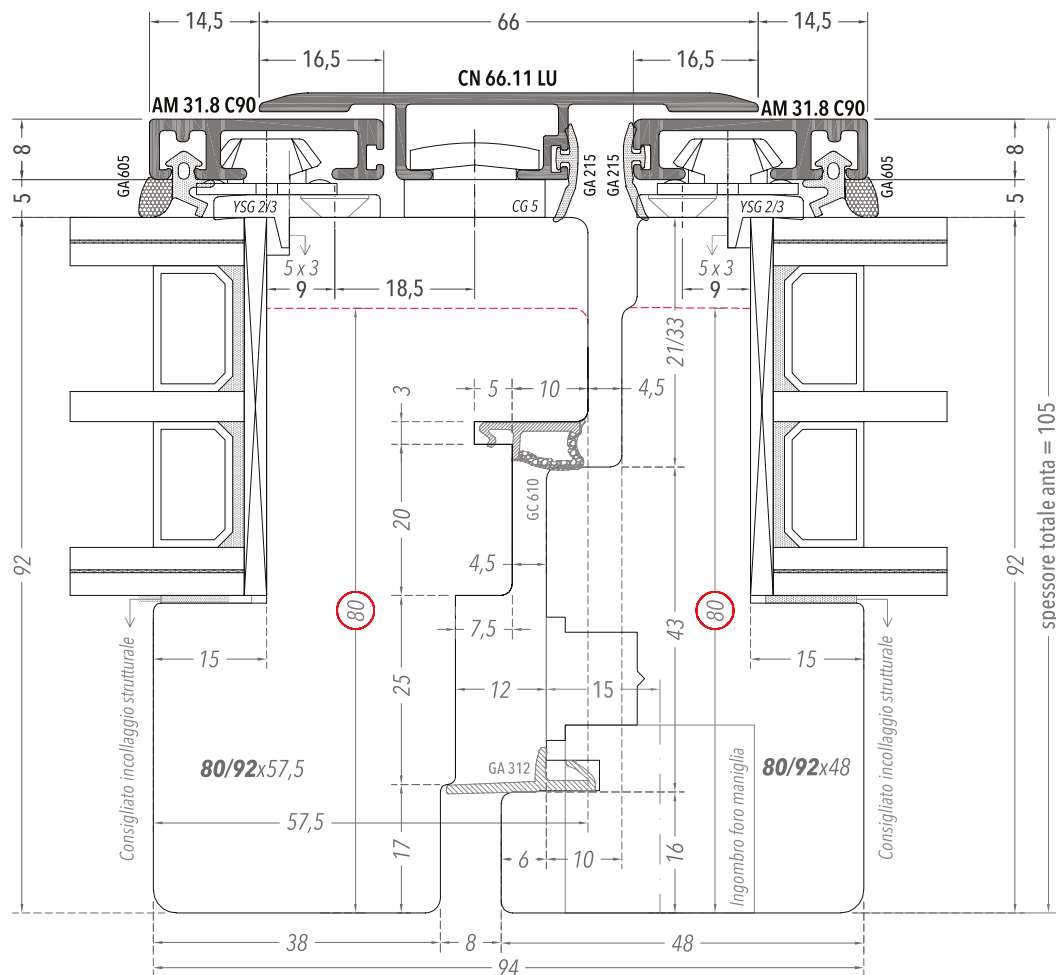

**PORTAFINESTRA**

SEZIONE VERTICALE  
NODO INFERIORE  
SCALA 1:1

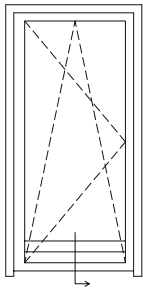

**SOLUZIONE  
SPESSORE  
ANTA 80**

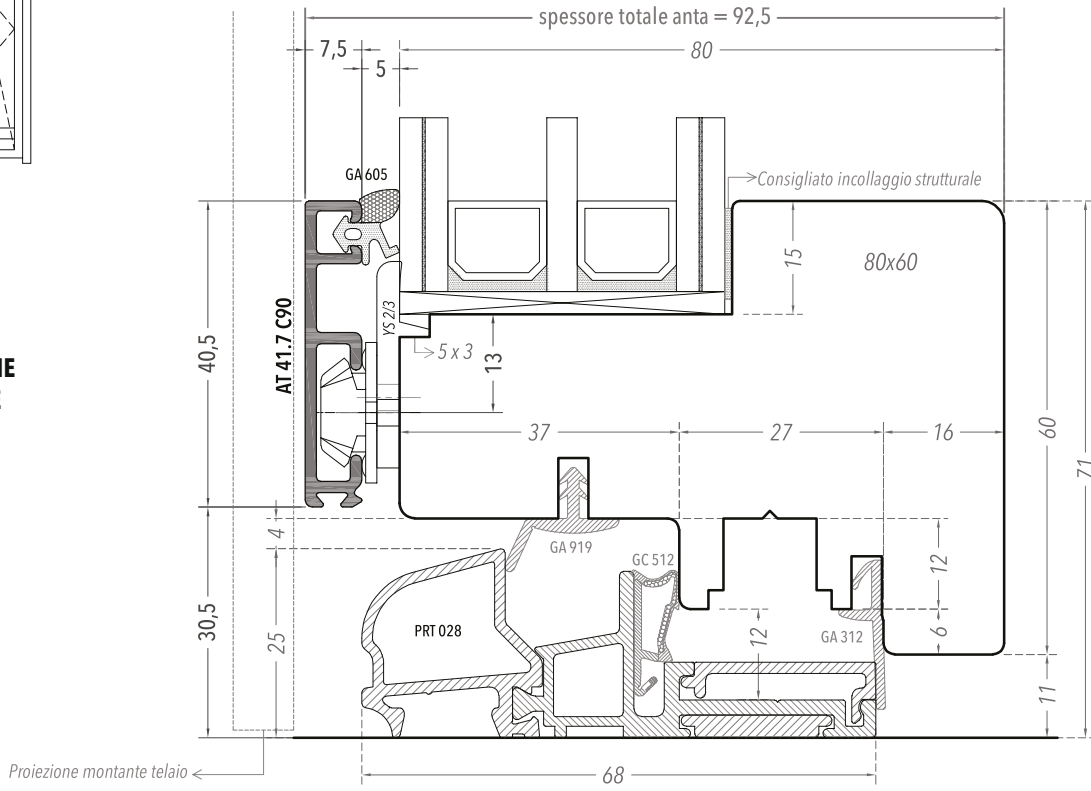

**SOLUZIONE  
SPESSORE  
ANTA 80/92**

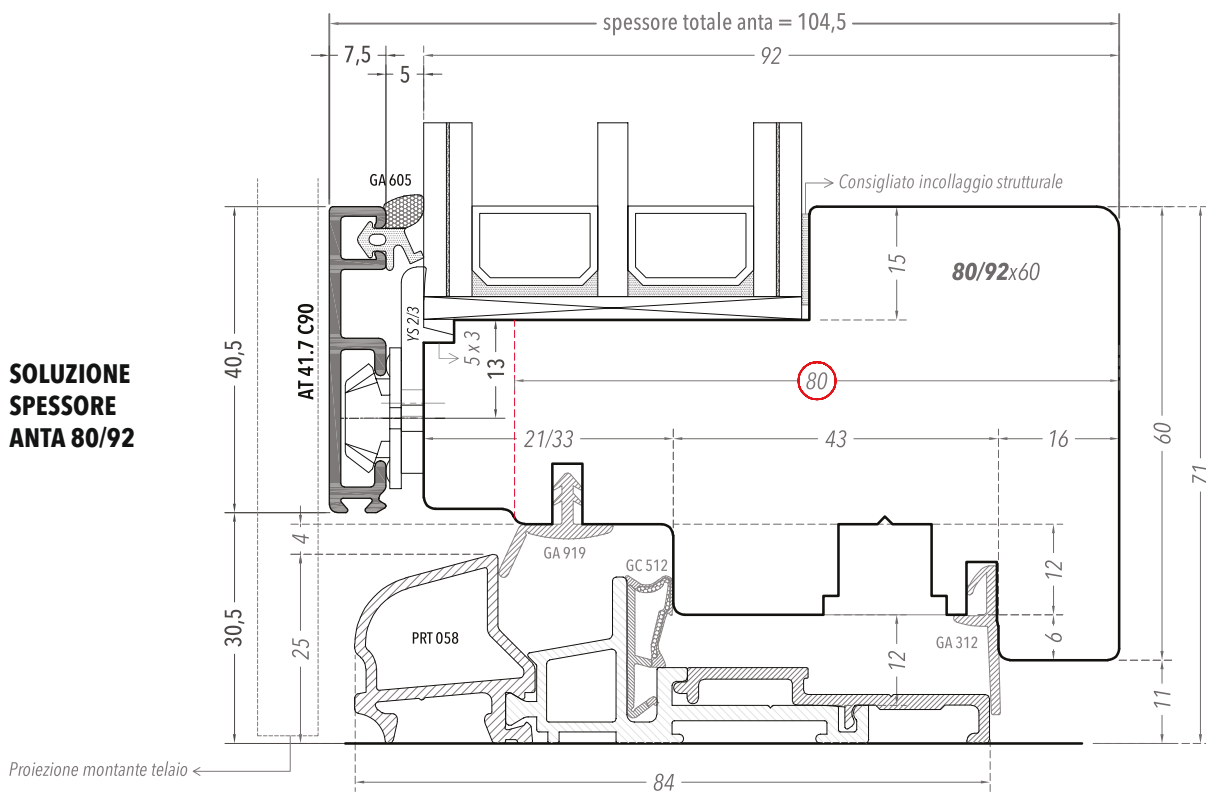





Spessore telaio 92  
Spessore anta 92

# Alumfast Canvas

---

ANTA TELAIO  
DI UGUALE  
SPESSORE

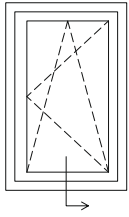

**SOLUZIONE  
SPESSORE  
ANTA 80**

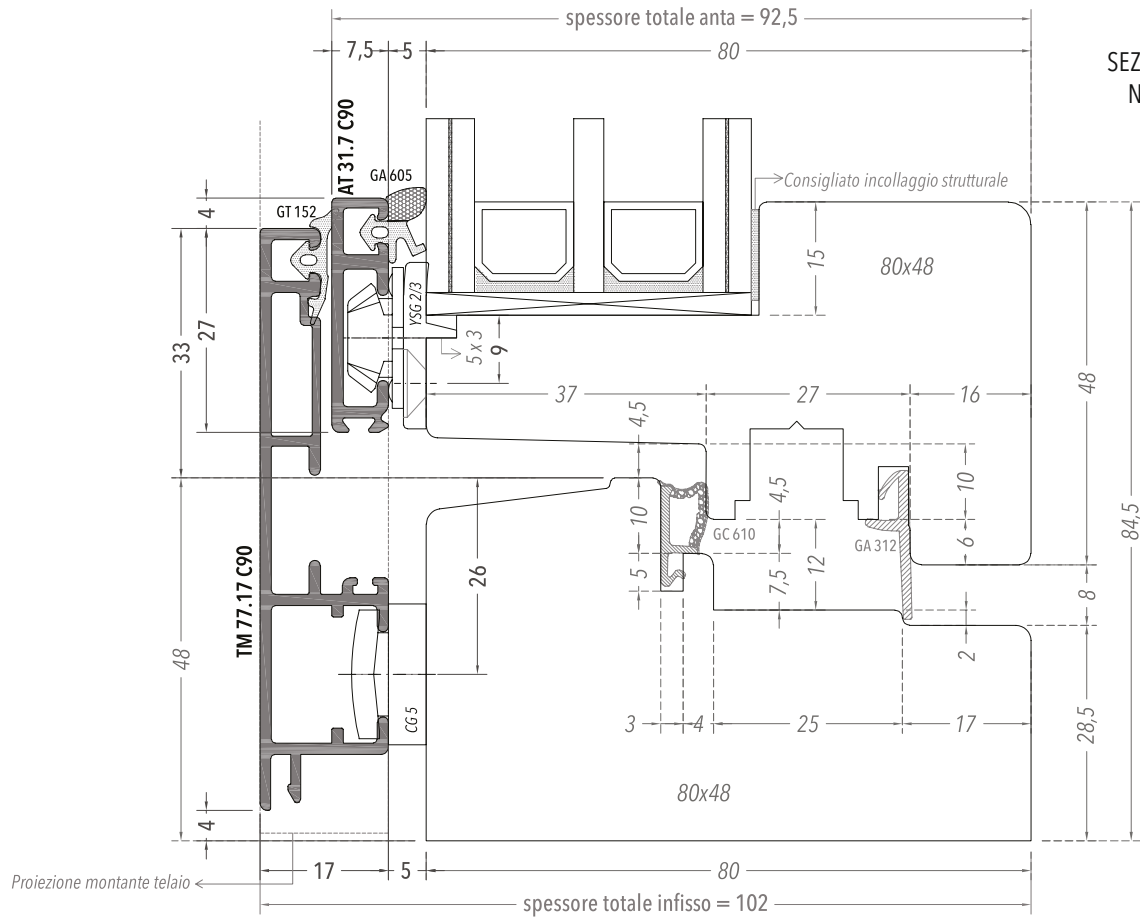

**FINESTRA**  
SEZIONE VERTICALE  
NODO INFERIORE  
SCALA 1:1

**SOLUZIONE  
SPESSORE  
ANTA 80/92**

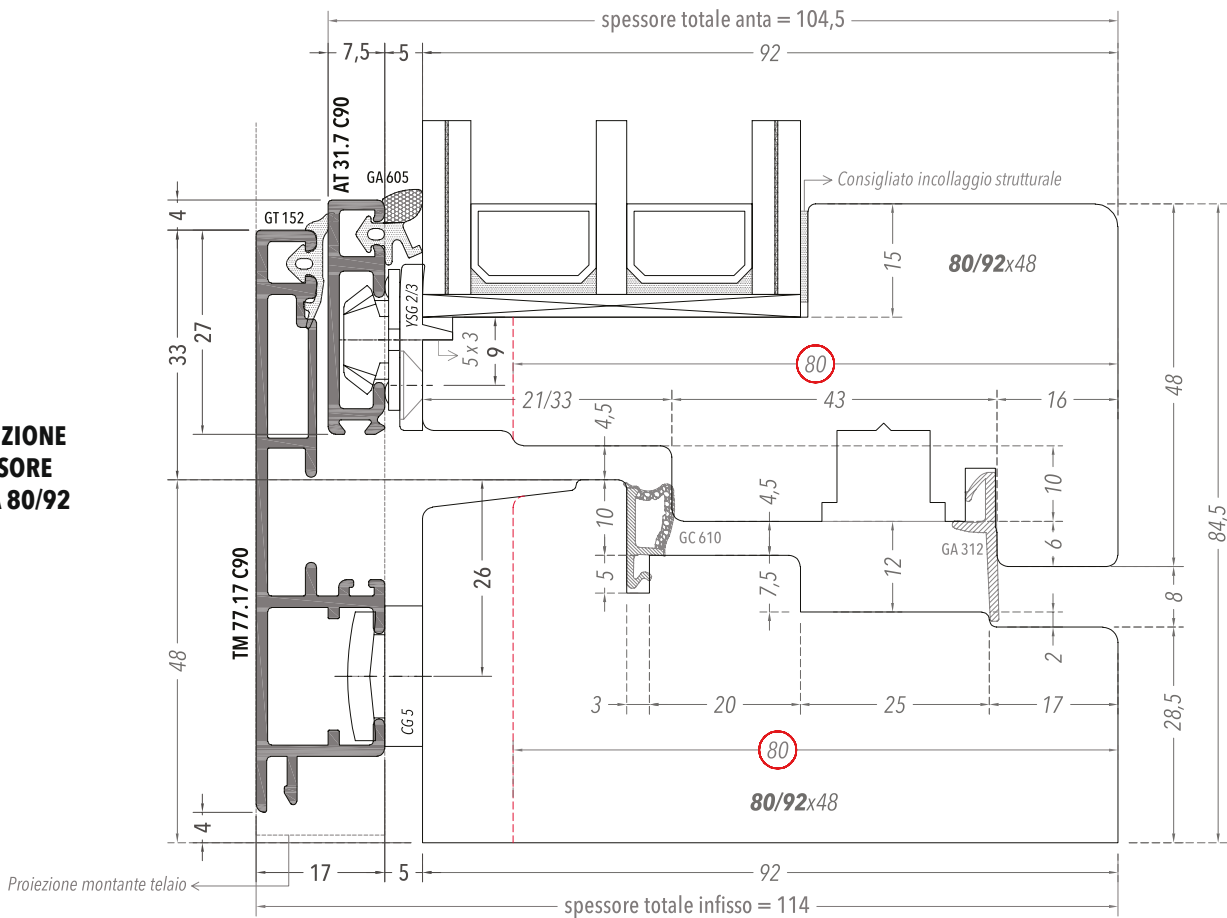

Varianti: telaio 80x48 e anta 80x48; telaio 92x48 e anta 92x48.



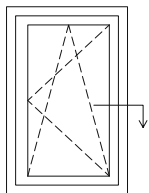

**SOLUZIONE  
SPESSORE  
ANTA 80**

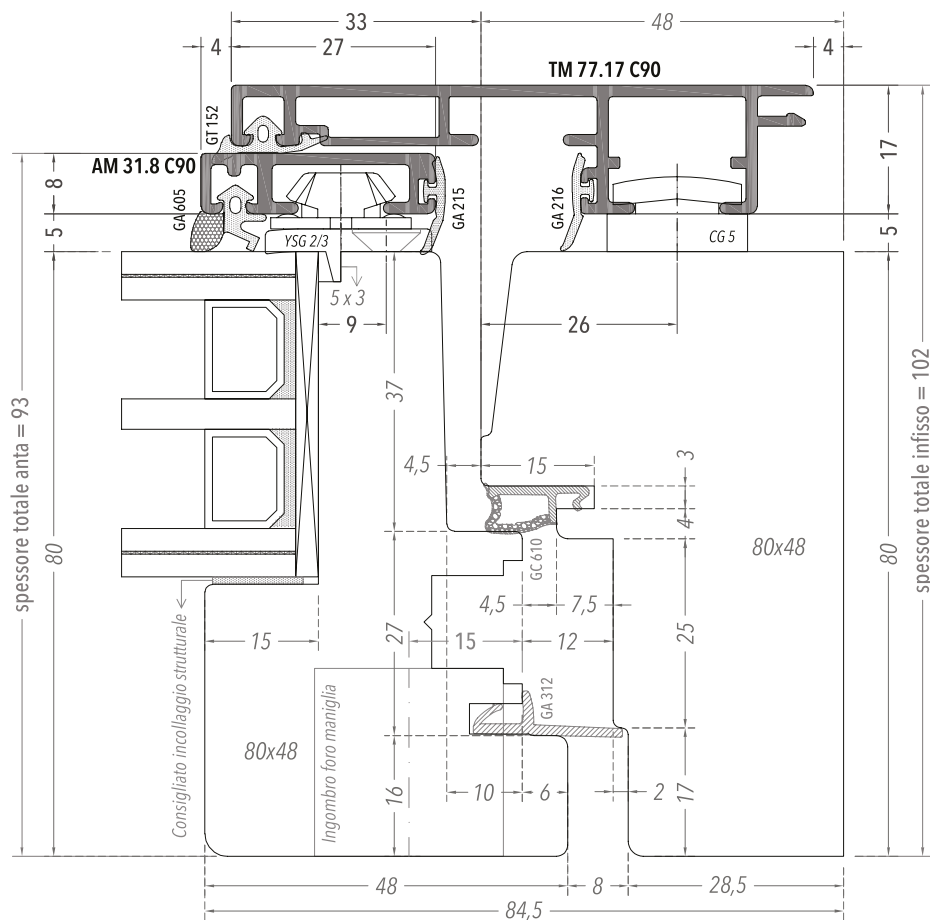

**FINESTRA**  
SEZIONE ORIZZONTALE  
NODO LATERALE  
SCALA 1:1

**SOLUZIONE  
SPESSORE  
ANTA 80/92**

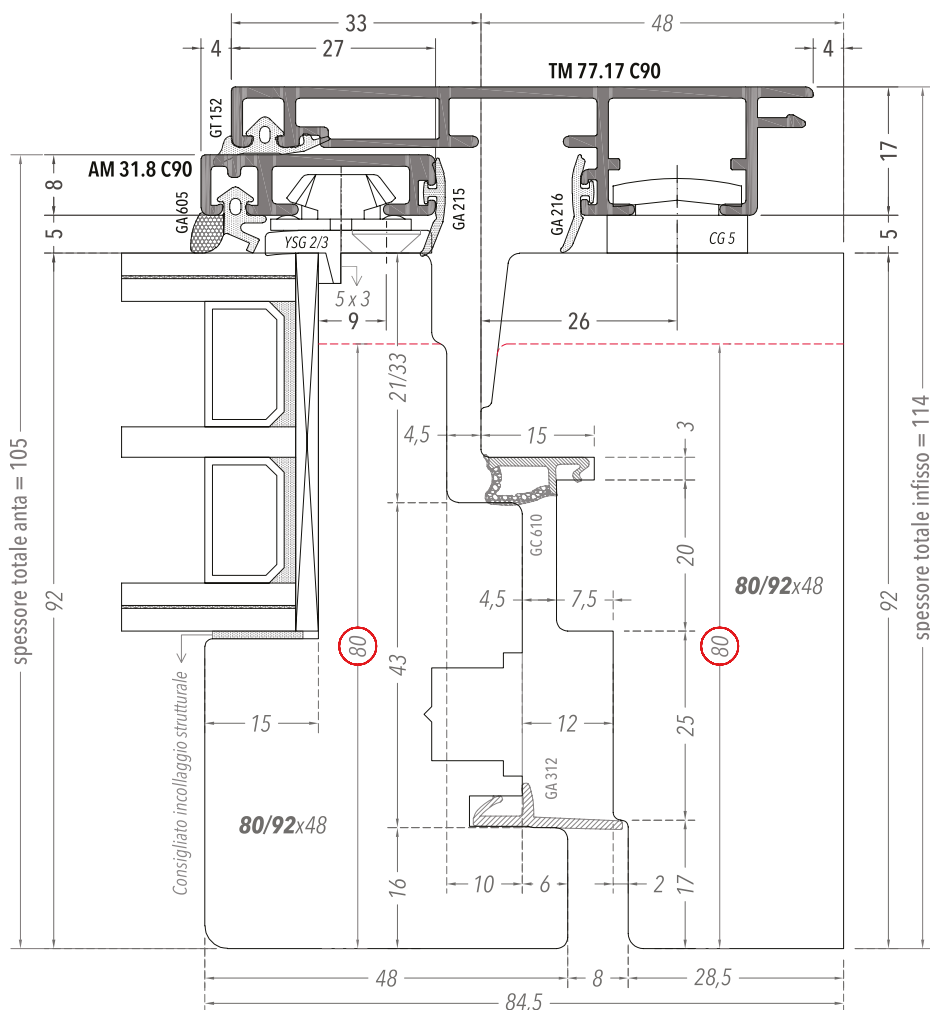

Varianti: telaio 80x48 e anta 80x48; telaio 92x48 e anta 92x48.

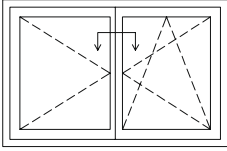

**FINESTRA**

SEZIONE ORIZZONTALE  
NODO CENTRALE  
SCALA 1:1

**SOLUZIONE  
SPESSORE  
ANTA 80**

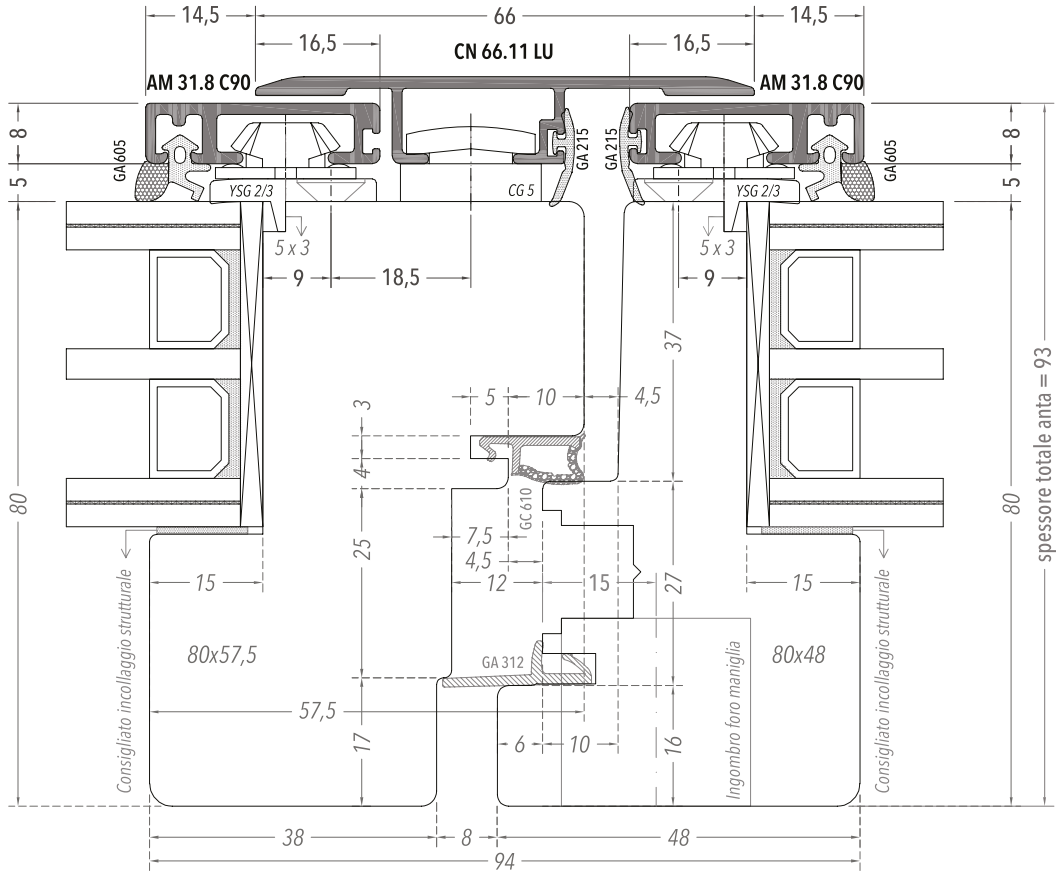

**SOLUZIONE  
SPESSORE  
ANTA 80/92**

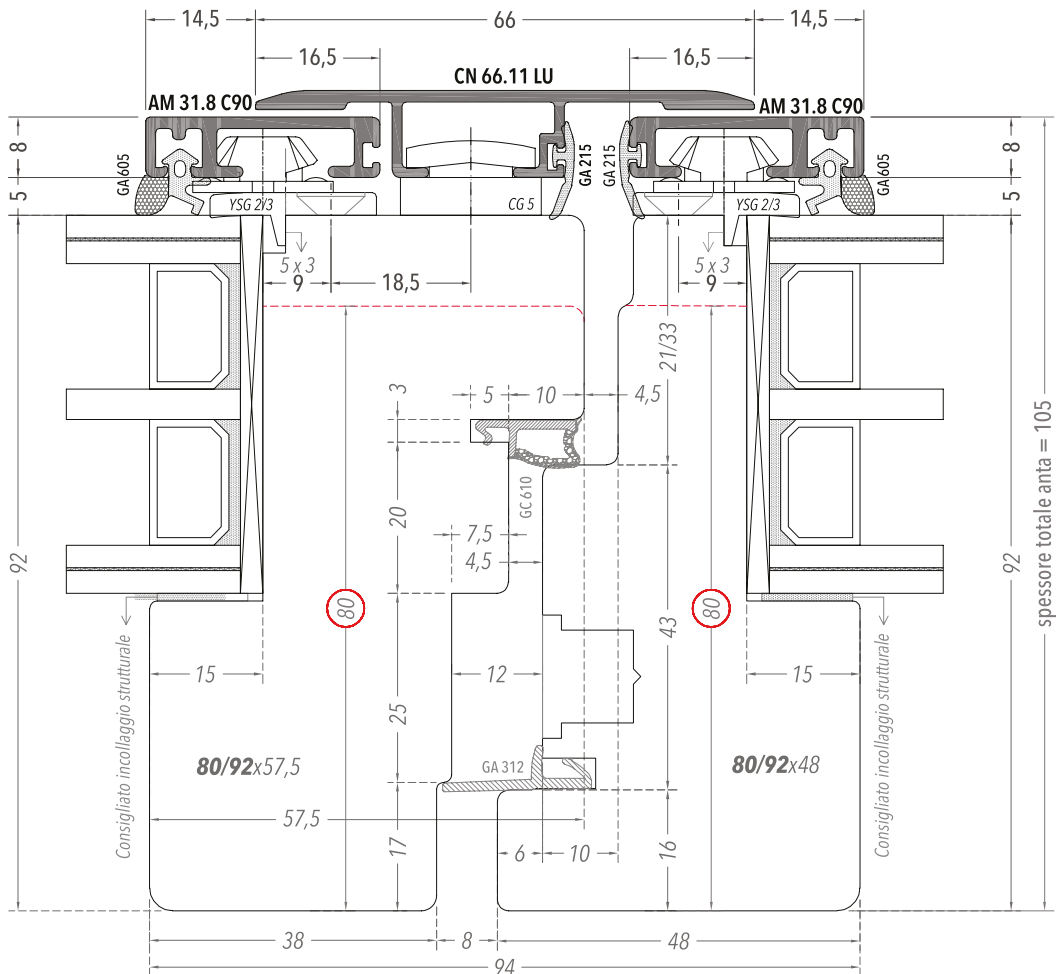

**PORTAFINESTRA**

SEZIONE VERTICALE  
NODO INFERIORE  
SCALA 1:1

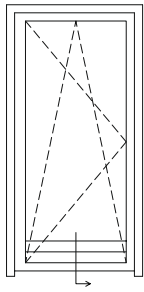

**SOLUZIONE  
SPESSORE  
ANTA 80**

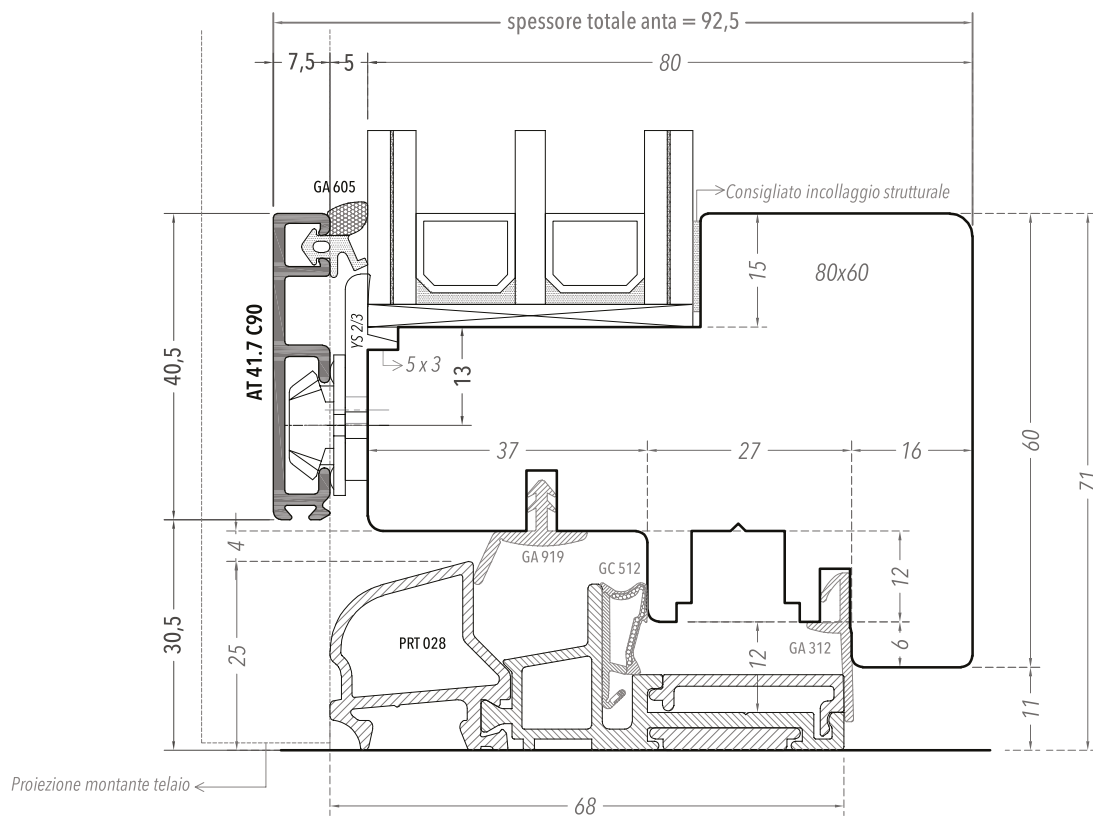

**SOLUZIONE  
SPESSORE  
ANTA 80/92**

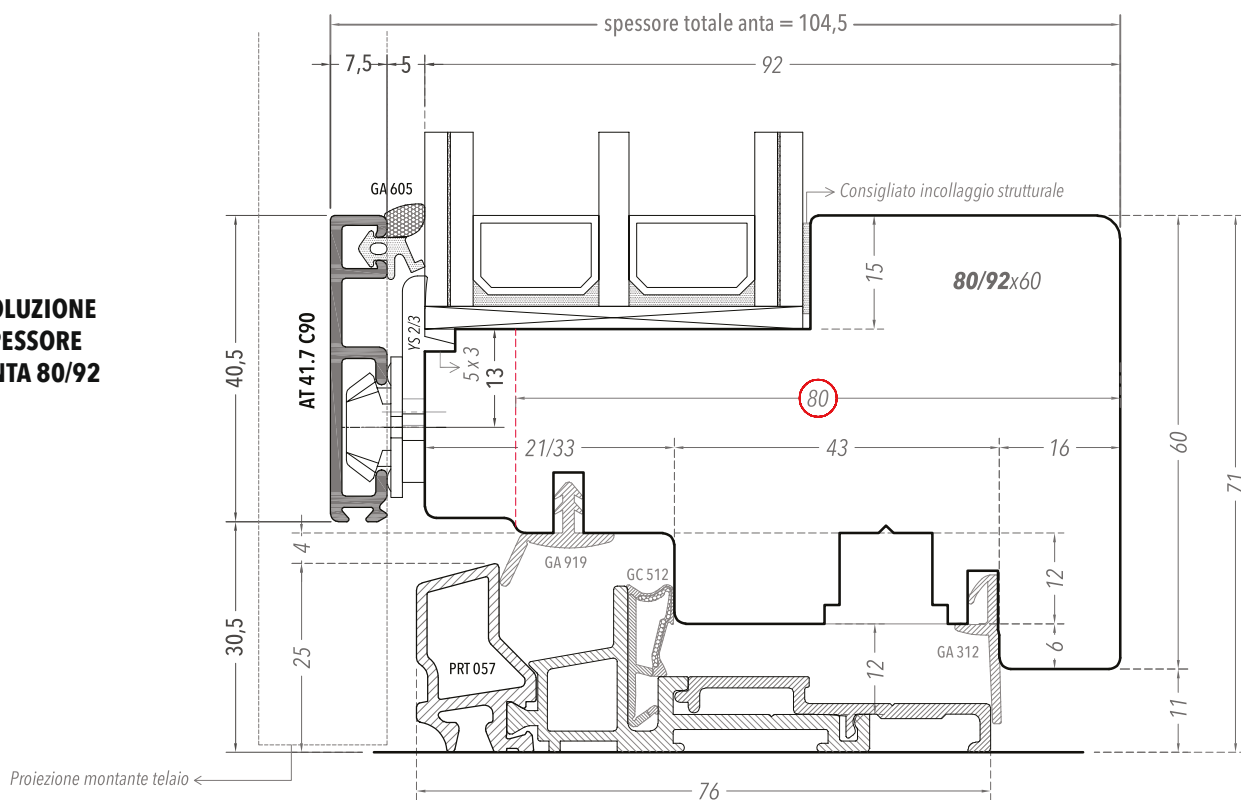



Spessore telaio 102  
Spessore anta 92

# Alumfast Canvas

---

ORIZON  
STANDARD

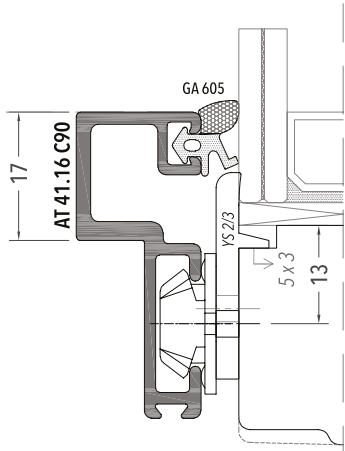

Variante con vetro a filo e profilo squadrato

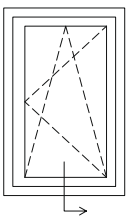

**FINESTRA**  
SEZIONE VERTICALE  
NODO INFERIORE

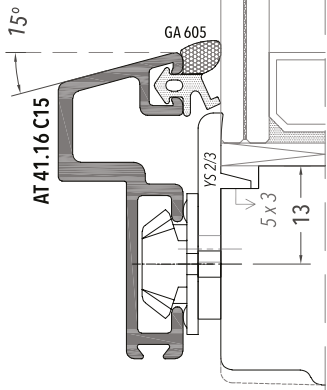

Variante Slide con profilo inclinato a 15°

Varianti:  
telaio 90x48 e anta 80x60;  
telaio 102x48 e anta 92x60.

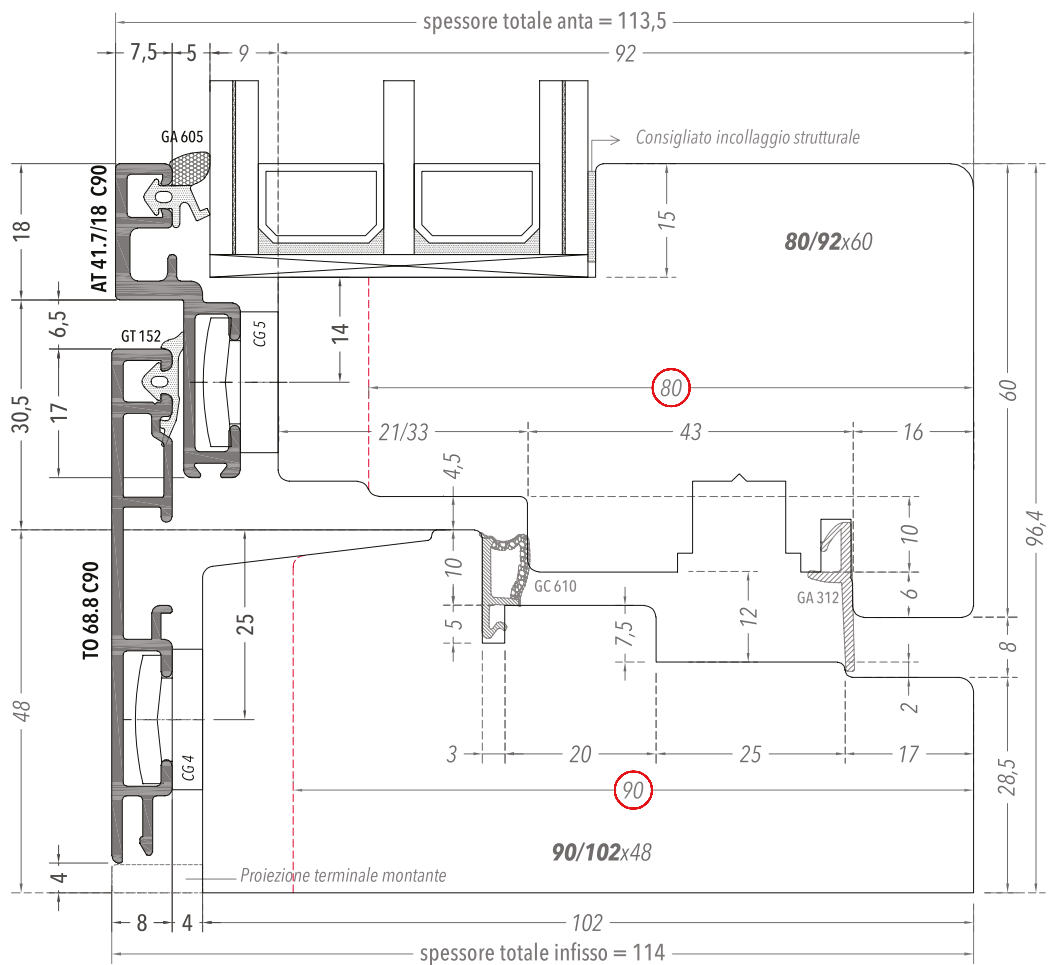
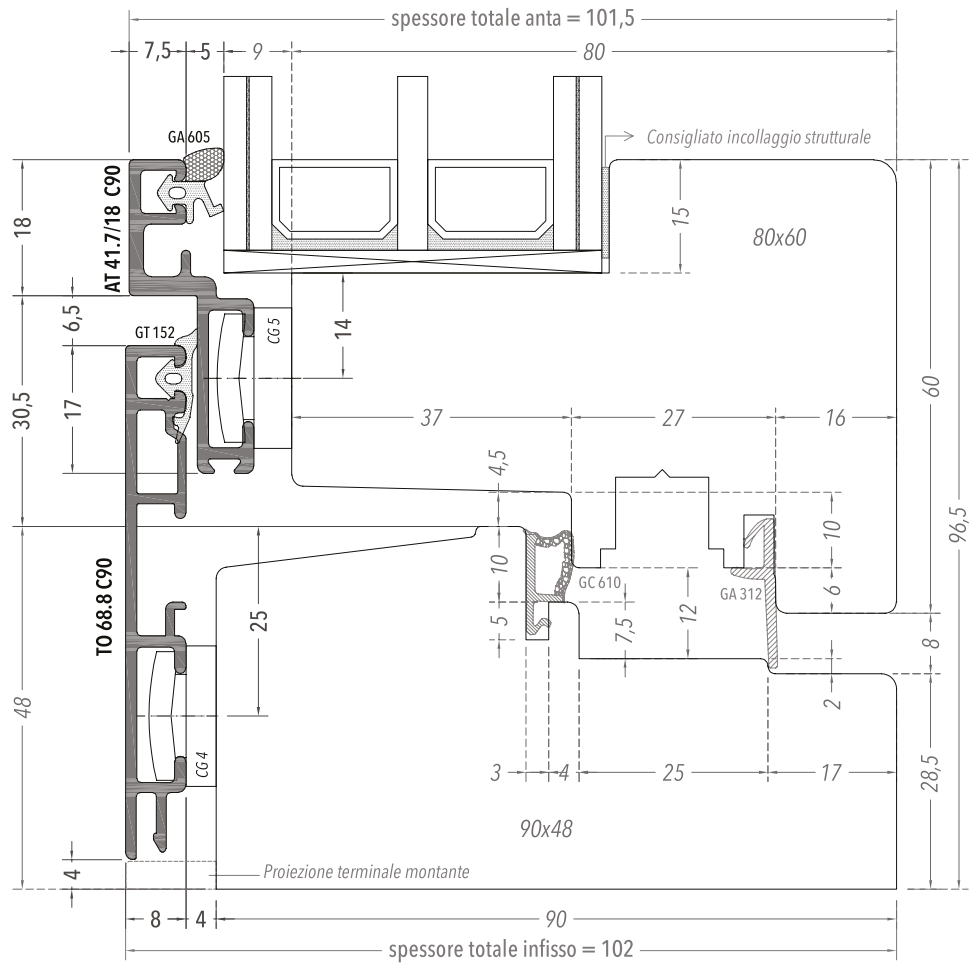

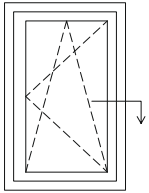

**FINESTRA**

SEZIONE ORIZZONTALE  
NODO LATERALE

**SOLUZIONI VETRO A SBALZO**

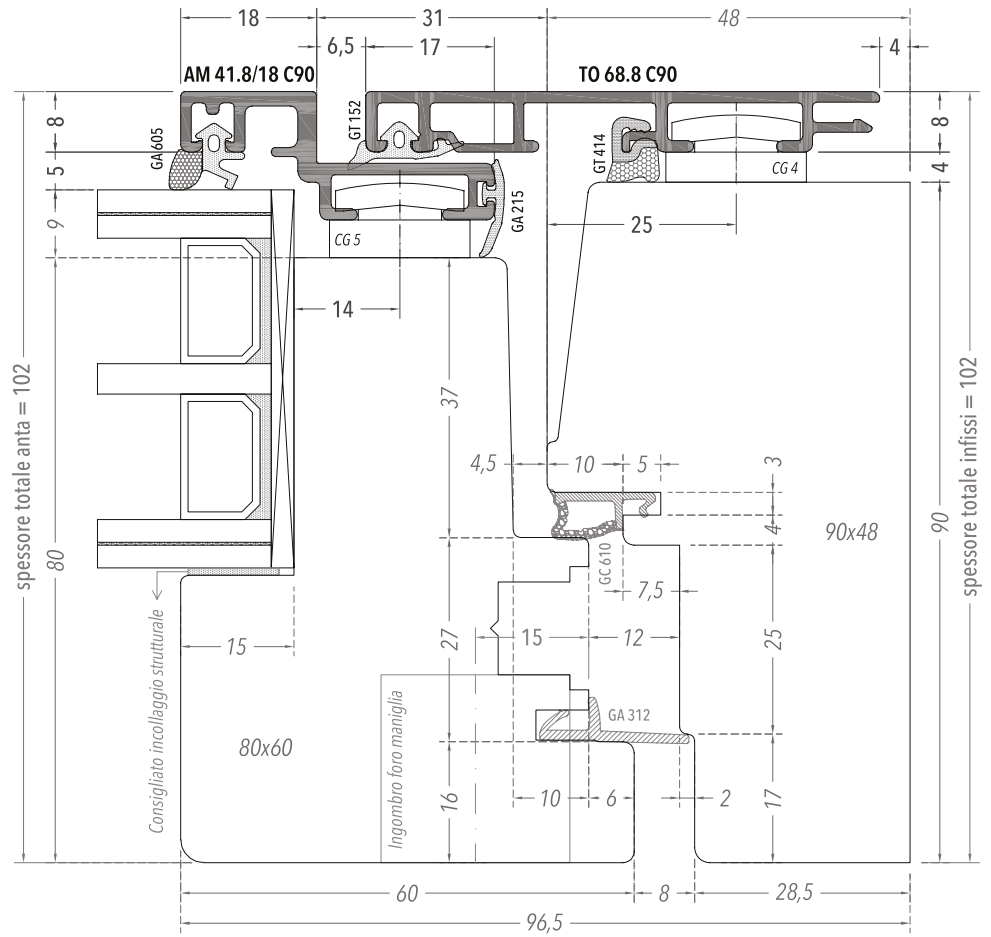

**SOLUZIONI VETRO A FILO**

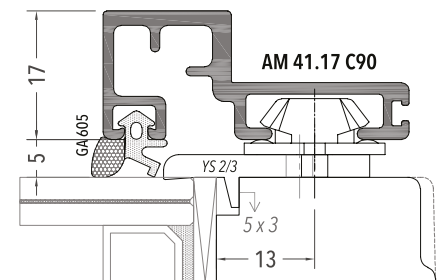

Variante con profilo squadrato

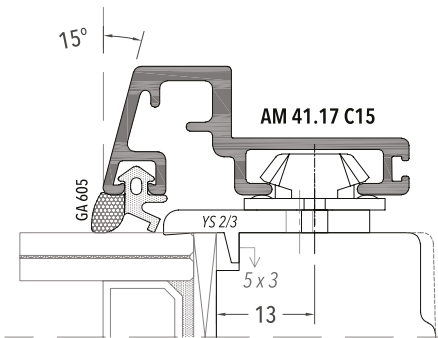

Variante Slide con profilo inclinato a 15°

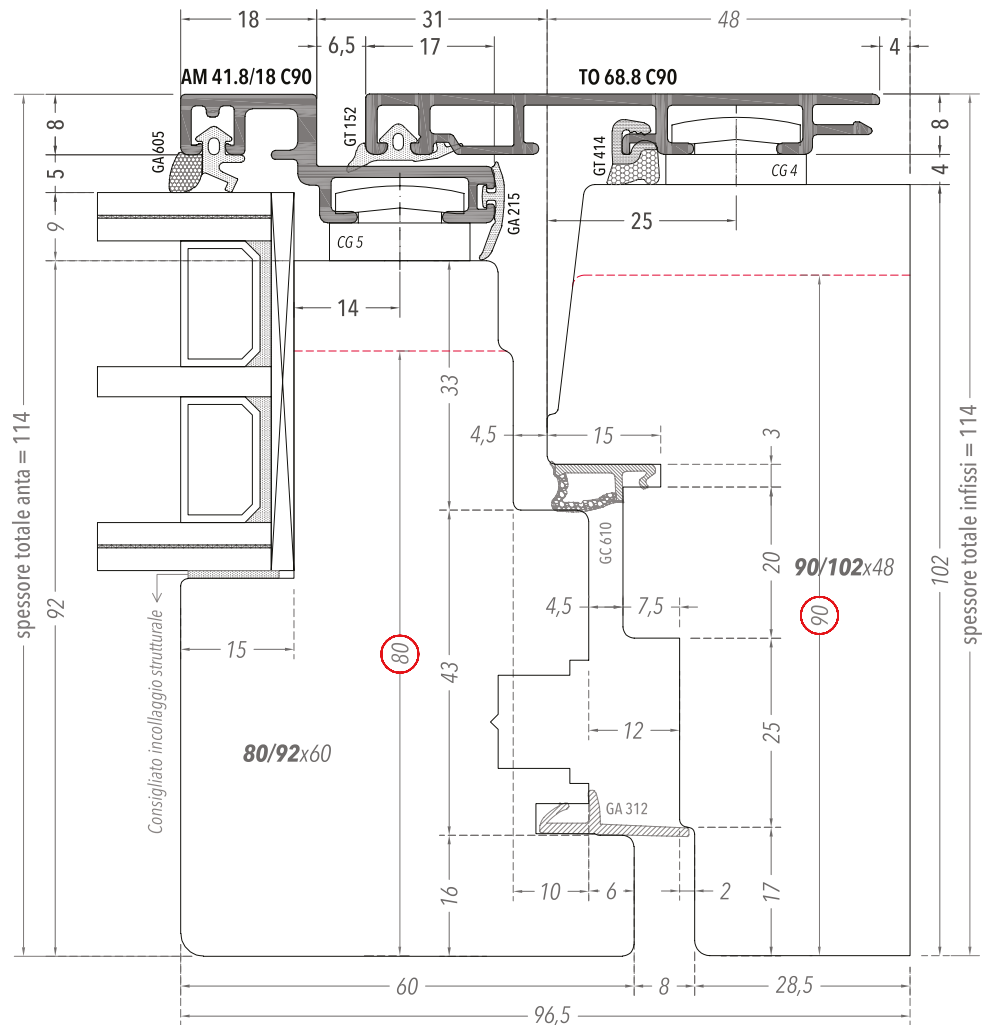

Varianti:  
telaio 90x48 e anta 80x60;  
telaio 102x48 e anta 92x60.

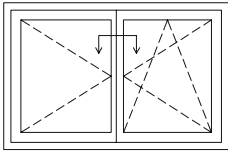

### FINESTRA

SEZIONE ORIZZONTALE  
NODO CENTRALE

SCALA 1:1

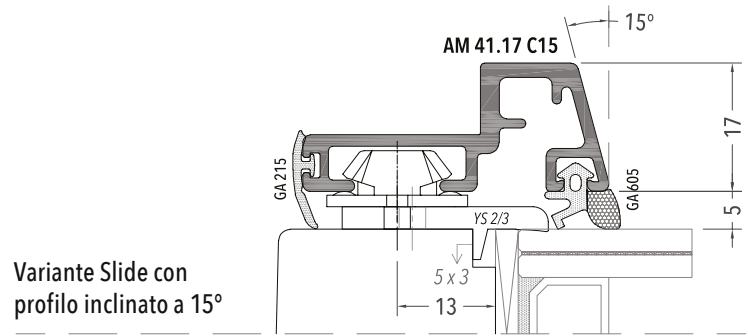

### SOLUZIONI VETRO A FILO

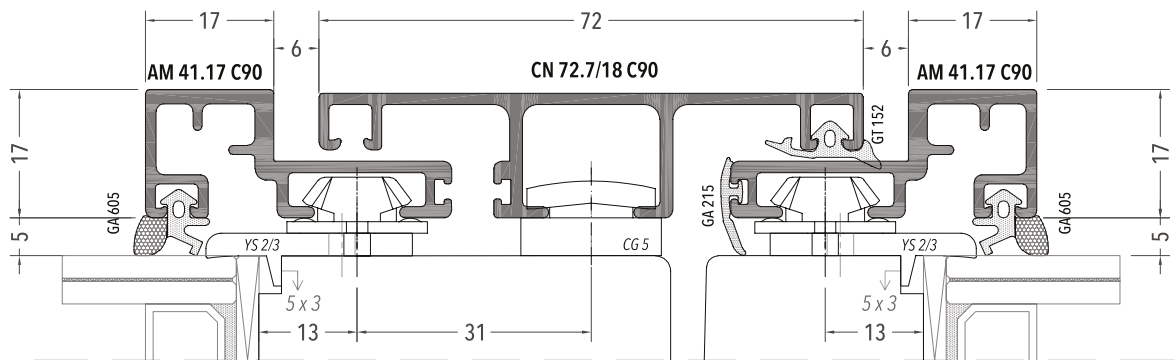

### SOLUZIONI VETRO A SBALZO

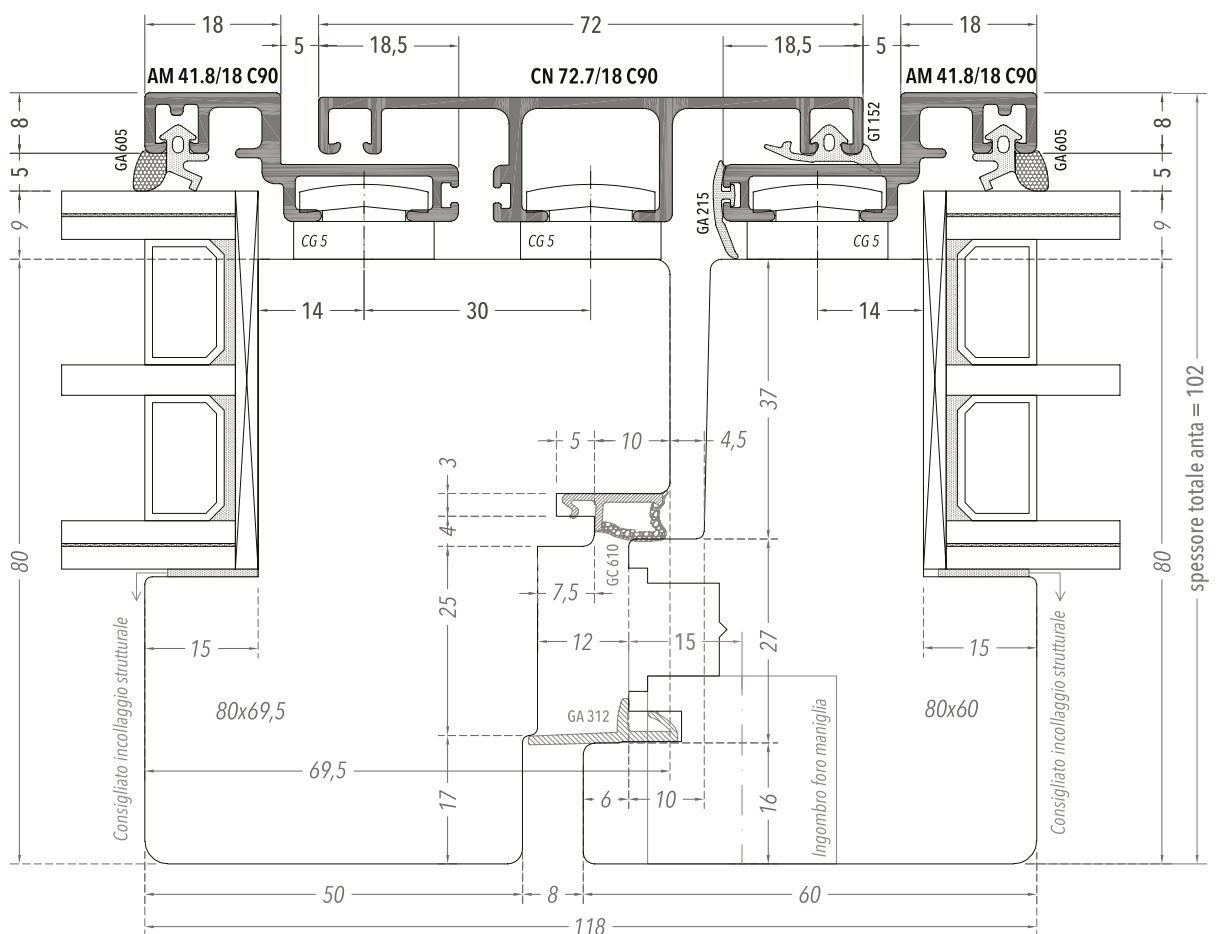



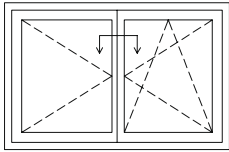

**FINESTRA**

SEZIONE ORIZZONTALE  
NODO CENTRALE

SCALA 1:1

Variante Slide con  
profilo inclinato a 15°

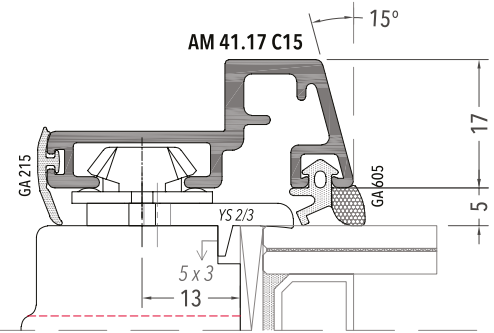

**SOLUZIONI  
VETRO A FILO**

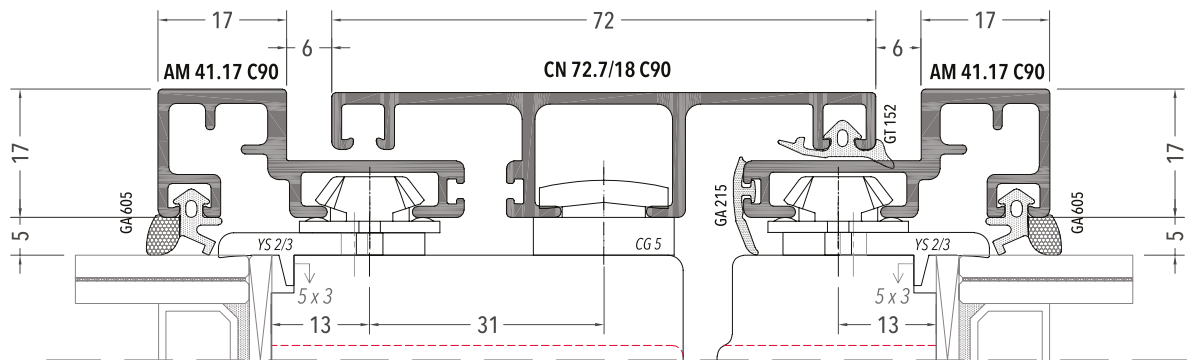

**SOLUZIONI VETRO  
A SBALZO**

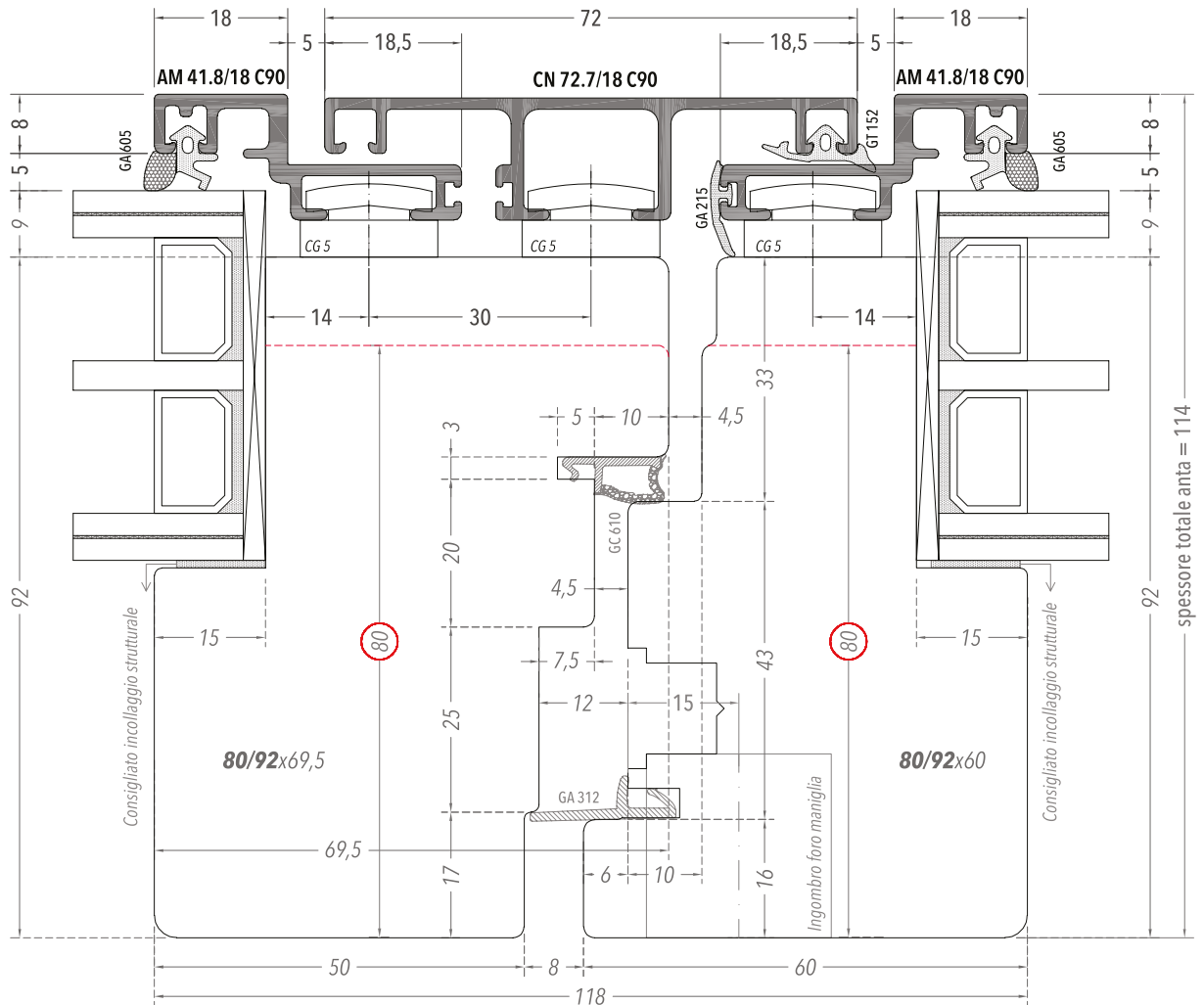

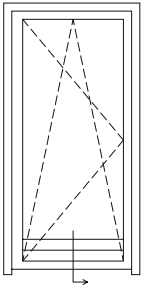

**PORTAFINESTRA**

SEZIONE VERTICALE  
NODO INFERIORE  
SCALA 1:1

**SOLUZIONI VETRO A FILO**

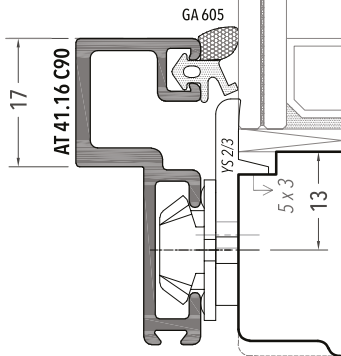

Variante con vetro a filo e profilo squadrato

**SOLUZIONI VETRO A SBALZO SPESSORE ANTA 80**

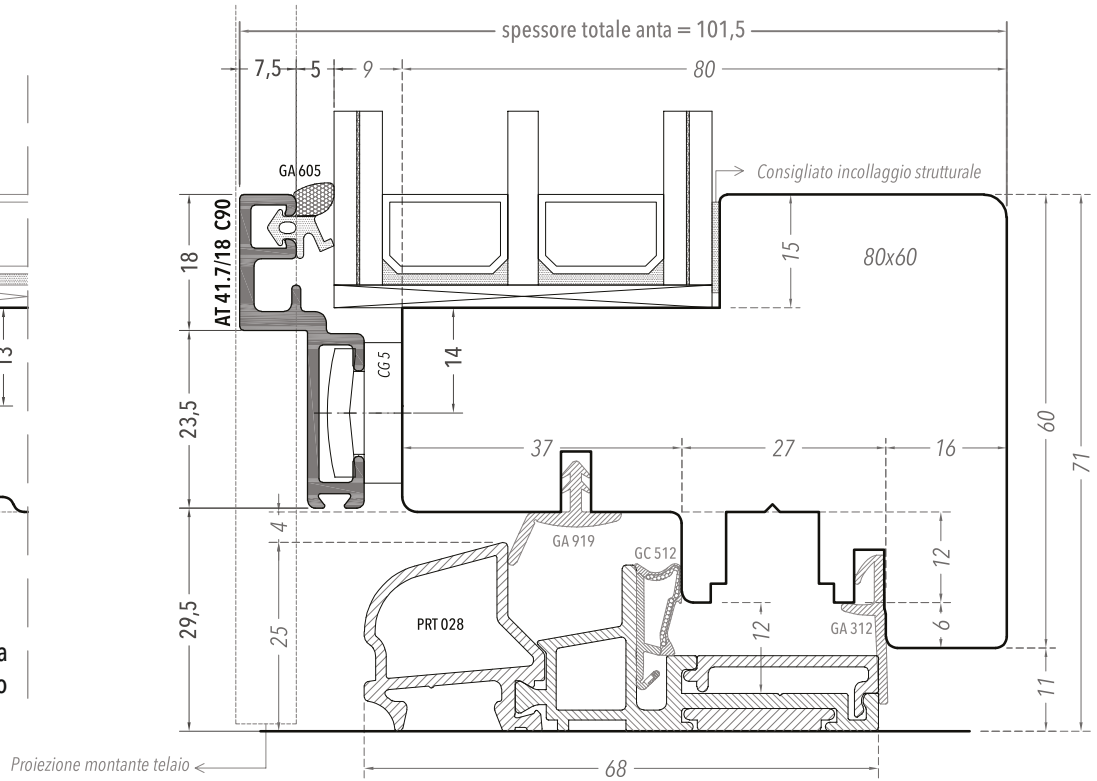

**SOLUZIONI VETRO A FILO**

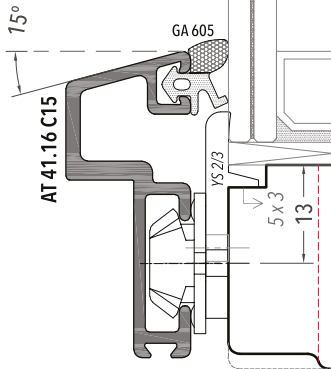

Variante Slide con profilo inclinato a 15°

**SOLUZIONI VETRO A SBALZO SPESSORE ANTA 80/92**

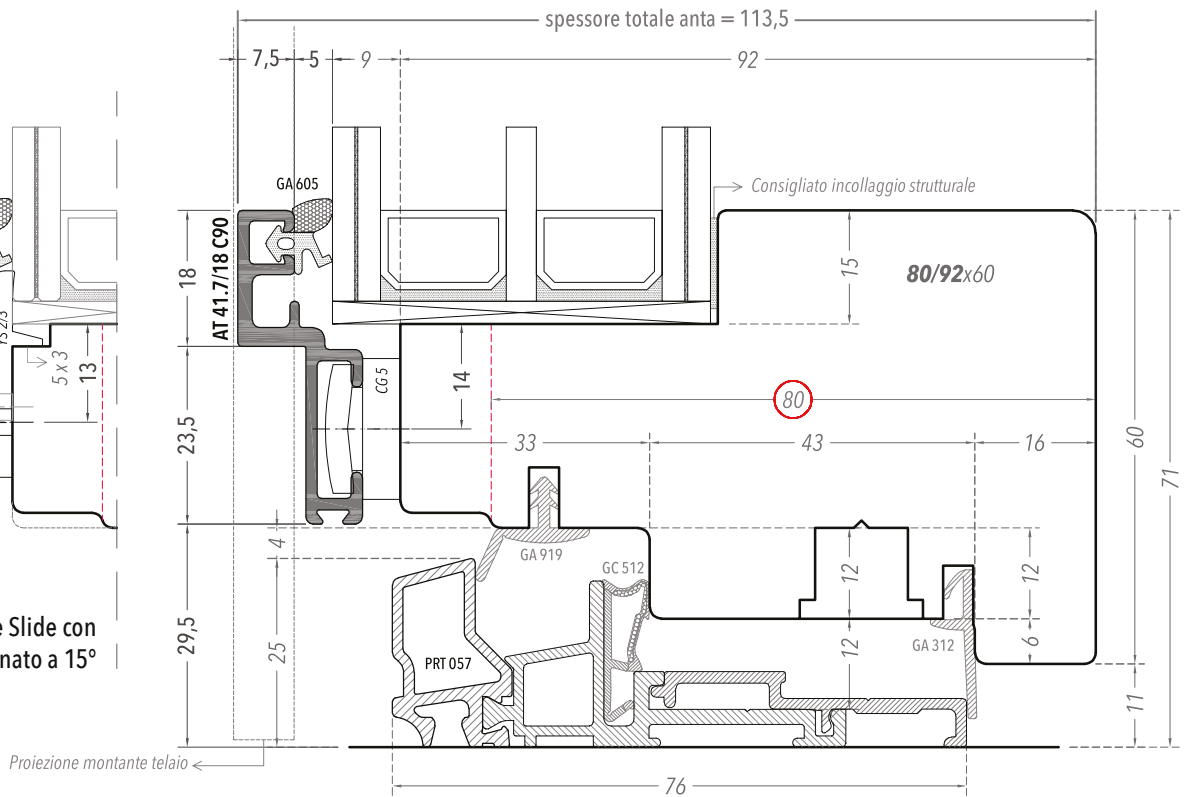





Spessore telaio 92  
Spessore anta 92

# Alumfast Canvas

---

ORIZON  
ANTATELAIO  
DI UGUALE  
SPESSORE

---

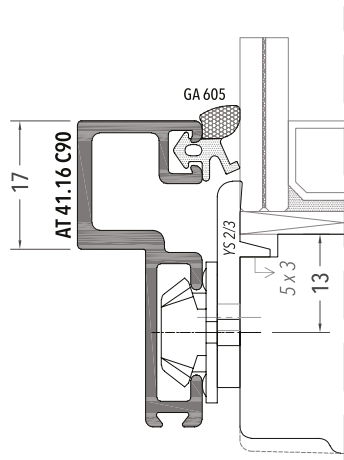

Variante con profilo squadrato

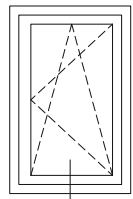

**FINESTRA**  
SEZIONE VERTICALE  
NODO INFERIORE

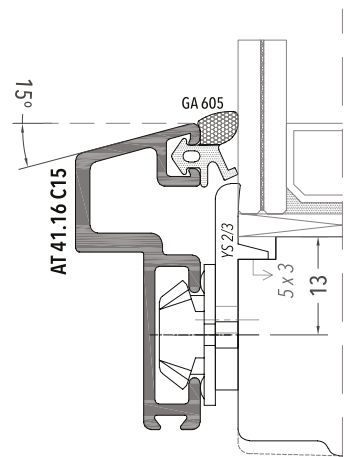

Variante Slide con profilo inclinato a 15°

Varianti:  
telaio 90x48  
e anta 80x60;  
telaio 92x48  
e anta 92x60.

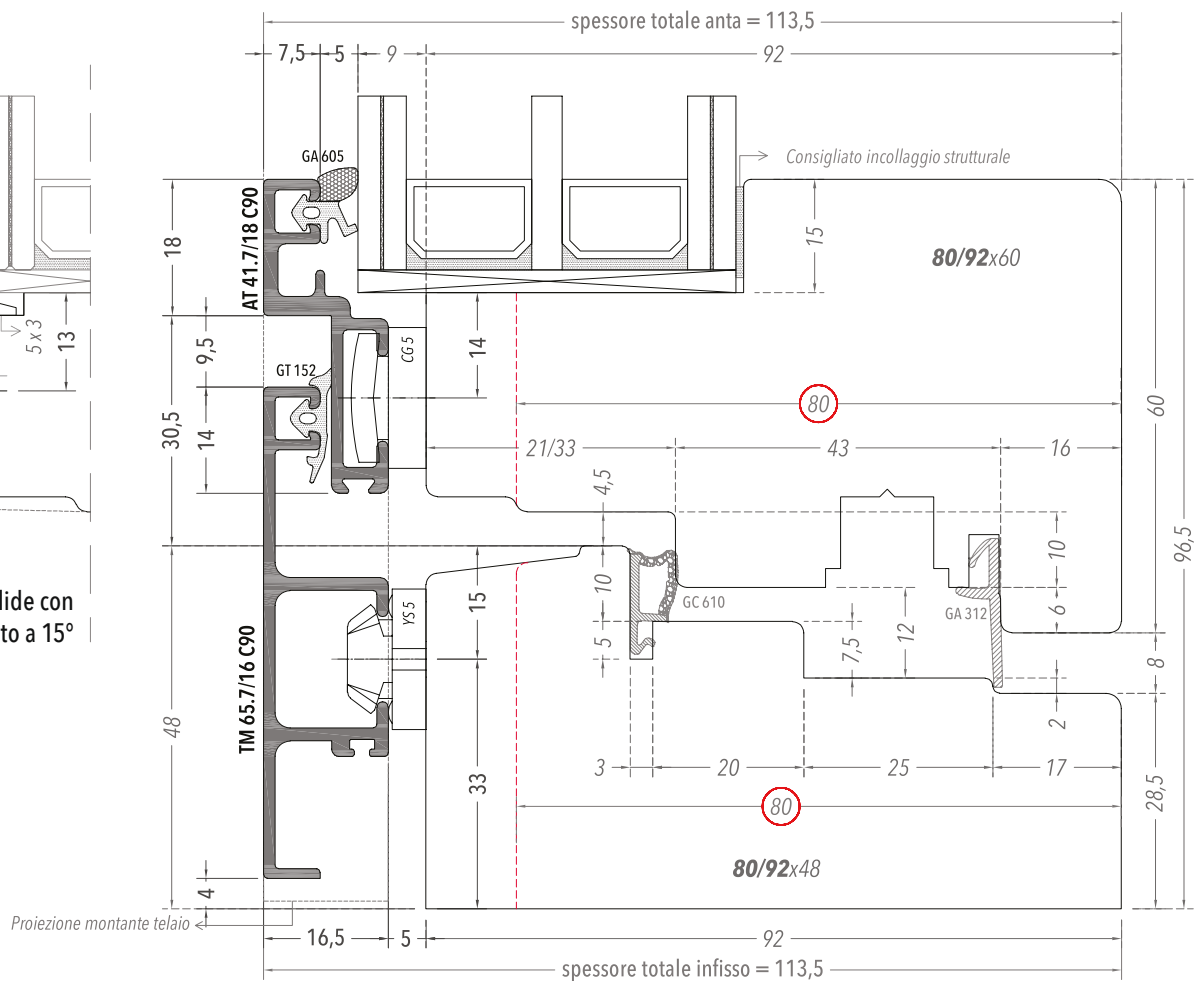
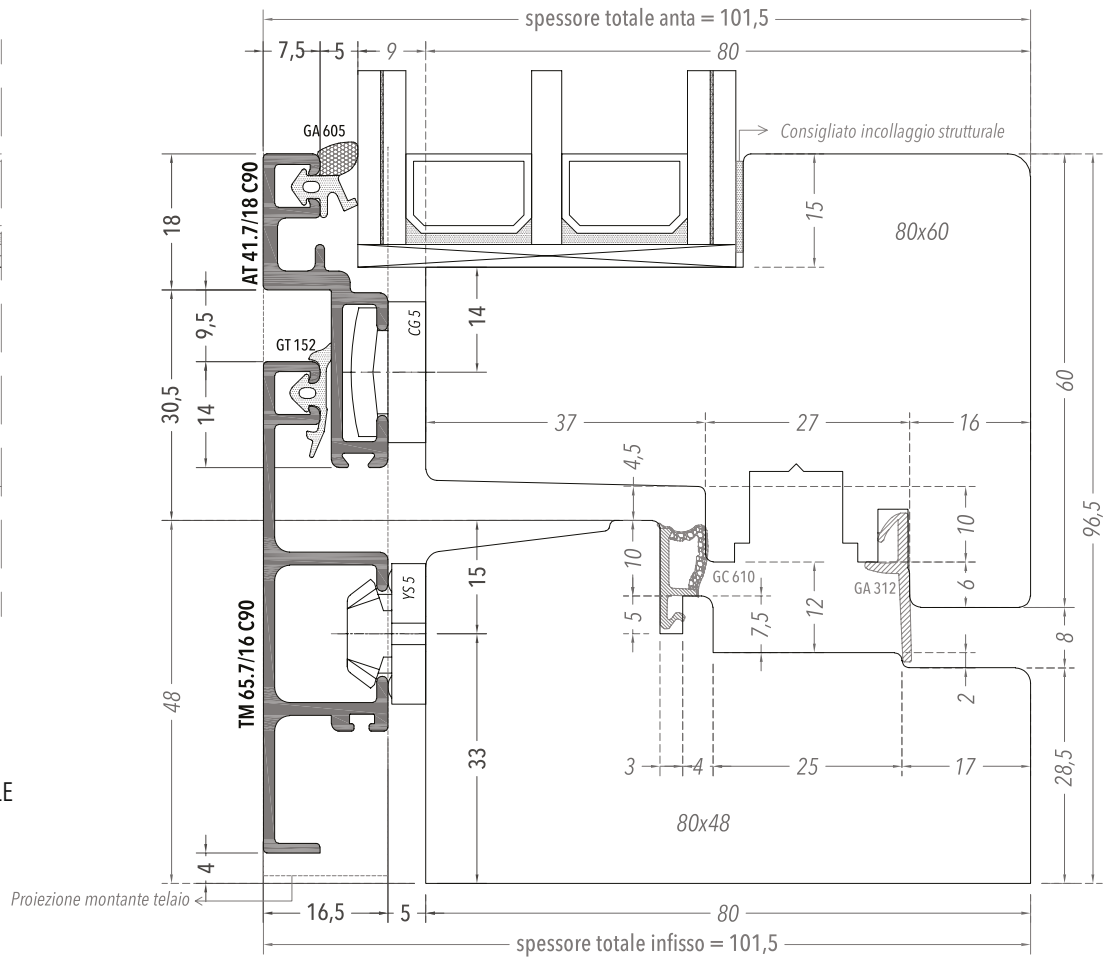

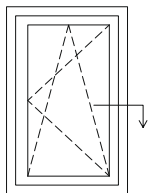

**FINESTRA**

SEZIONE ORIZZONTALE  
NODO LATERALE

**SOLUZIONI VETRO A SBALZO**

SCALA 1:1

**SOLUZIONI VETRO A FILO**

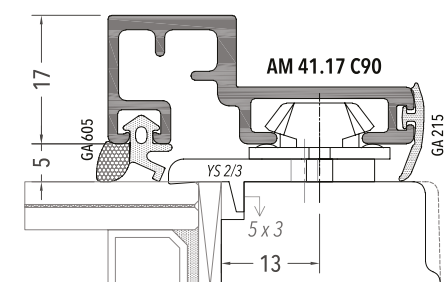

Variante con profilo squadrato

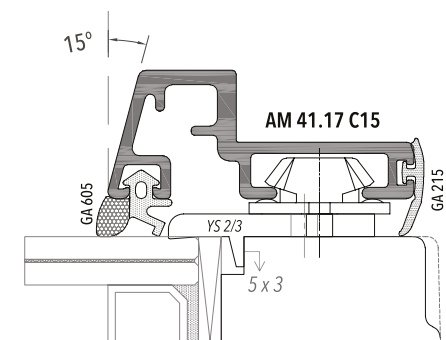

Variante Slide con profilo inclinato a 15°

Varianti:  
telaio 90x48 e anta 80x60;  
telaio 92x48 e anta 92x60.

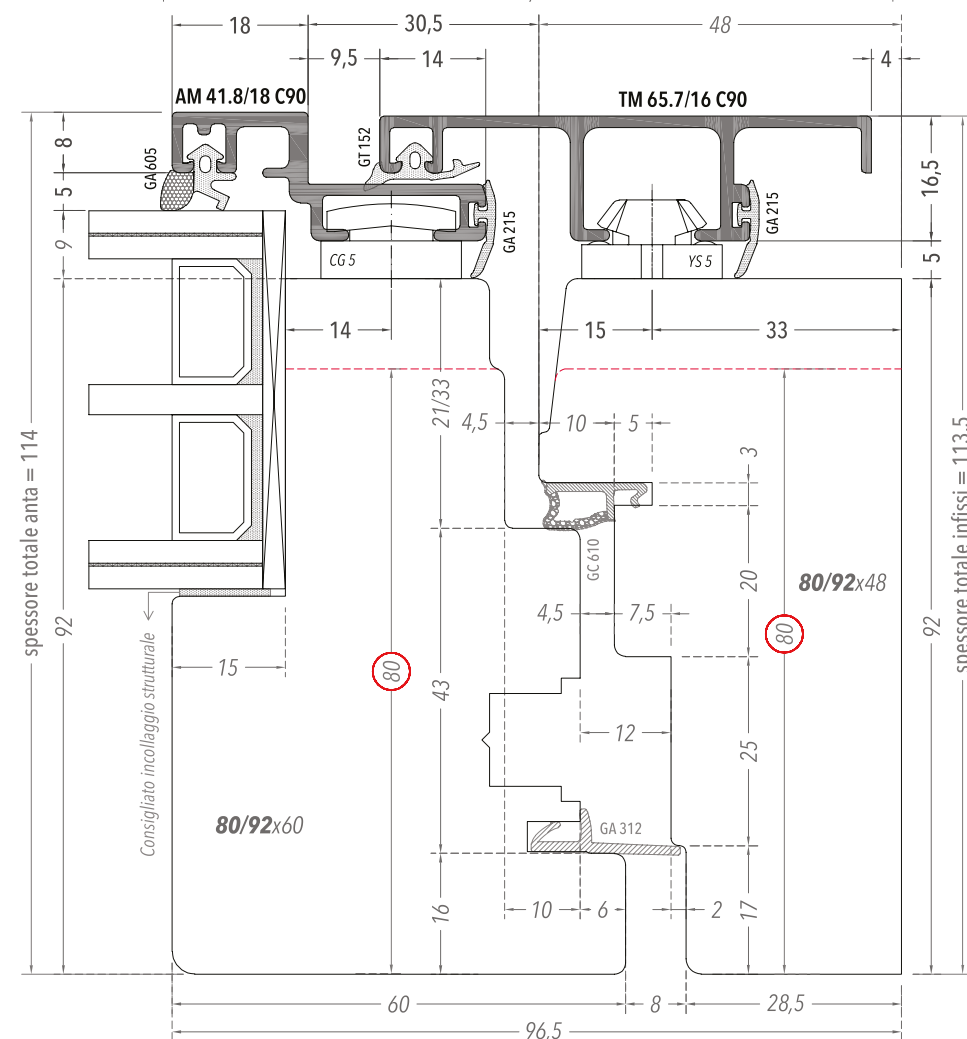
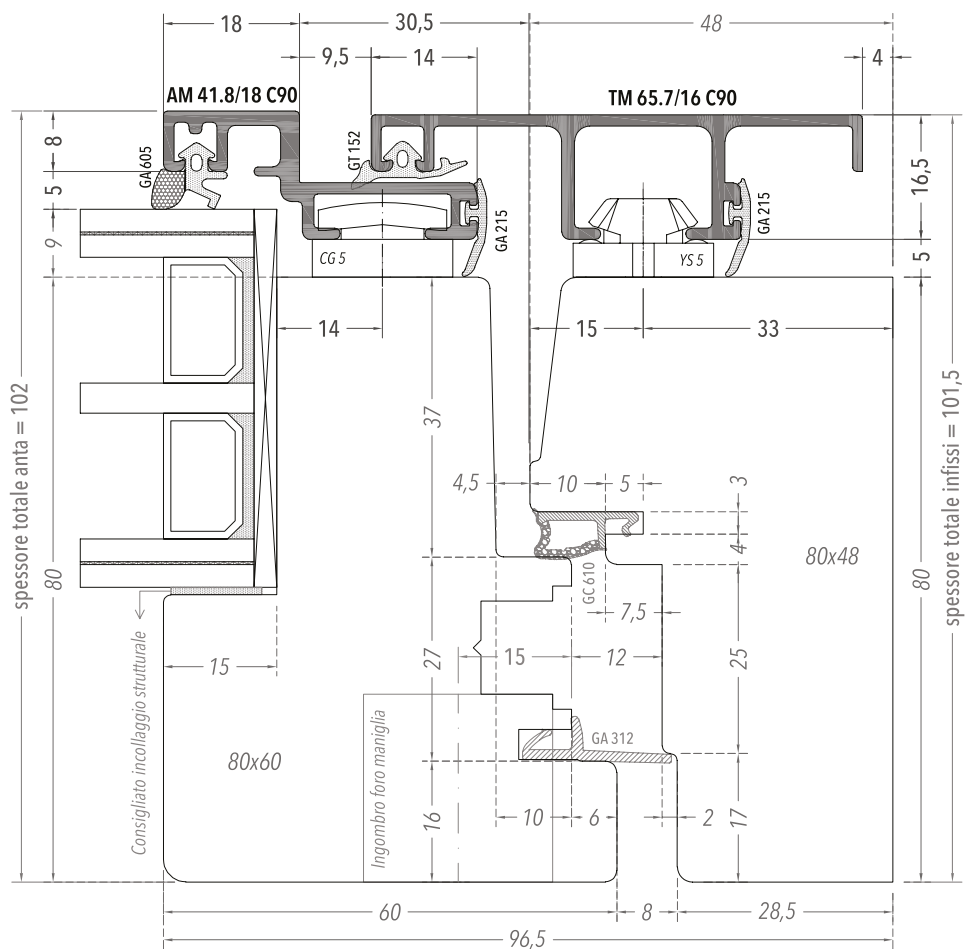

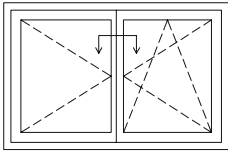

**FINESTRA**

SEZIONE ORIZZONTALE  
NODO CENTRALE

SCALA 1:1

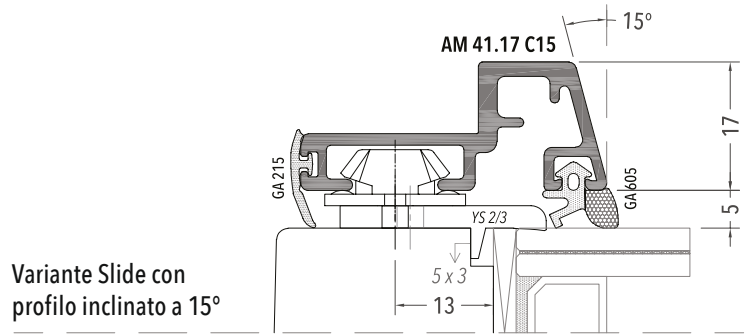

**SOLUZIONI  
VETRO A FILO**

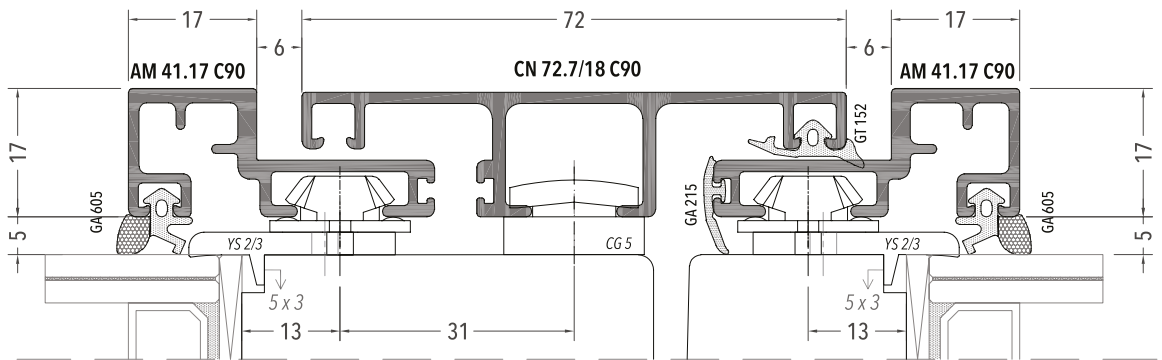

**SOLUZIONI VETRO  
A SBALZO**

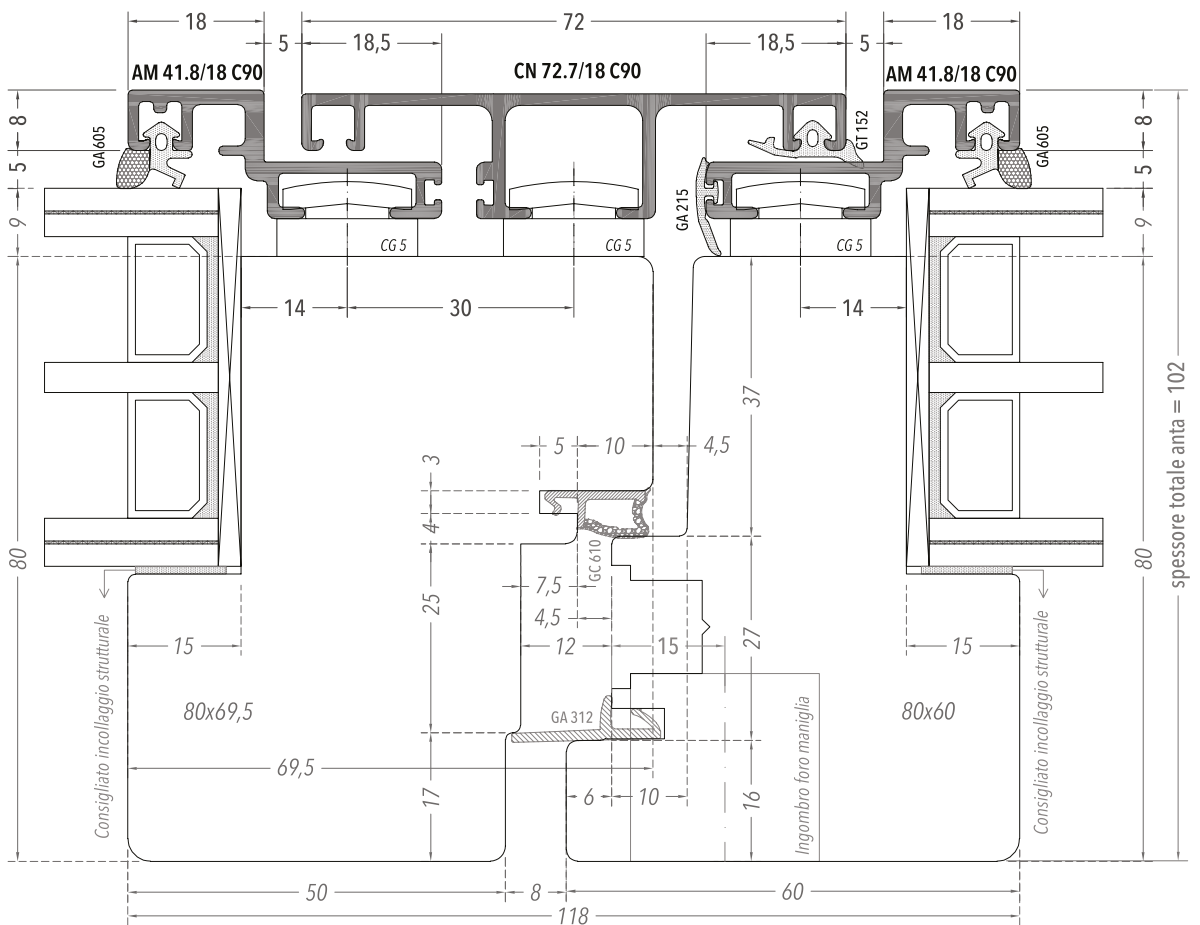



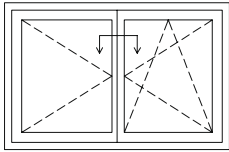

**FINESTRA**

SEZIONE ORIZZONTALE  
NODO CENTRALE

SCALA 1:1

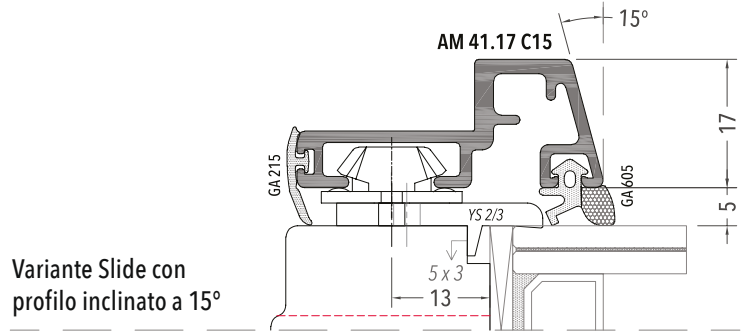

Variante Slide con  
profilo inclinato a 15°

**SOLUZIONI  
VETRO A FILO**

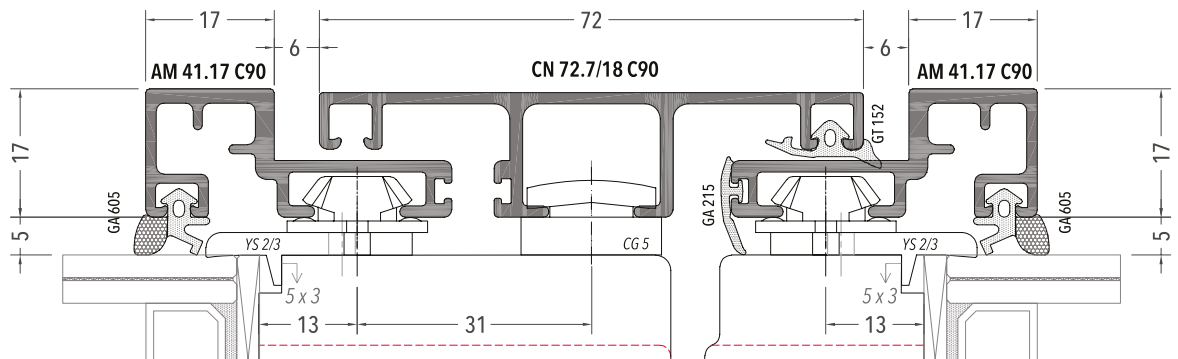

**SOLUZIONI VETRO  
A SBALZO**

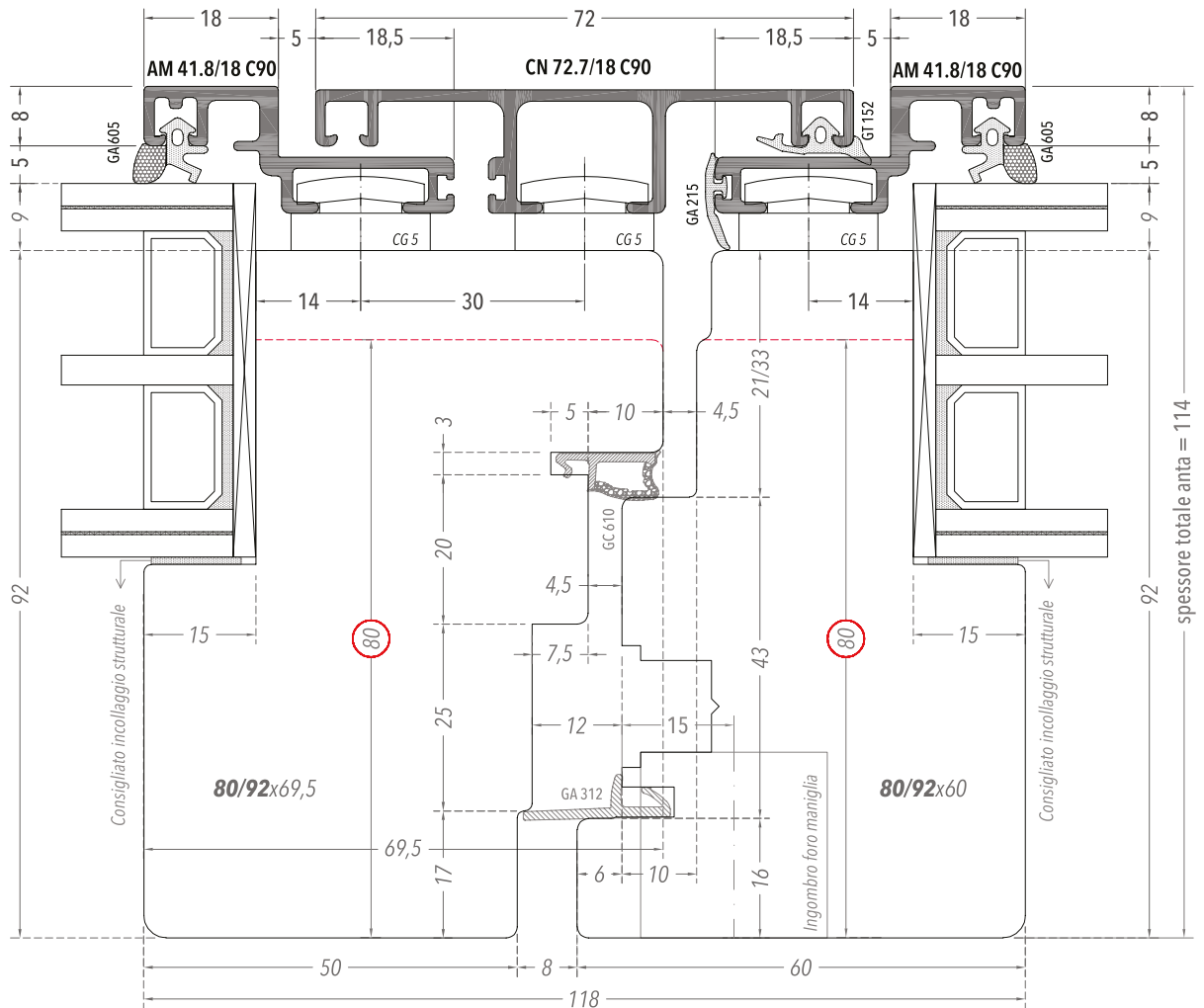

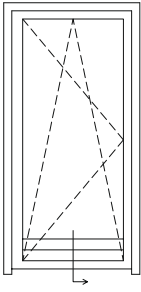

**PORTAFINESTRA**

SEZIONE VERTICALE  
NODO INFERIORE  
SCALA 1:1

**SOLUZIONI VETRO A FILO**

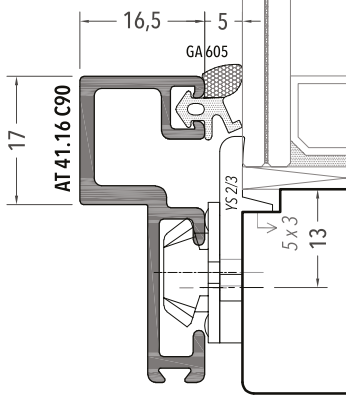

Variante con  
profilo squadrato

**SOLUZIONI VETRO A SBALZO SPESSORE ANTA 80**

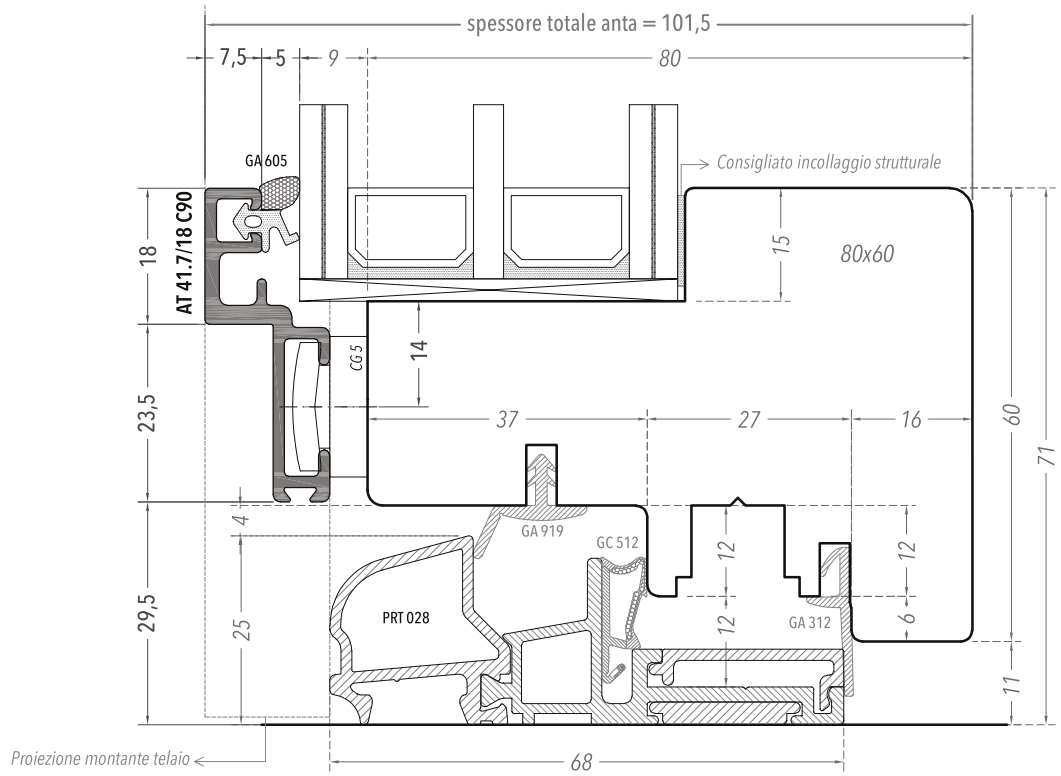

**SOLUZIONI VETRO A FILO**

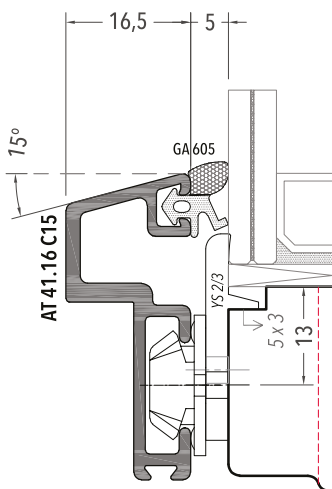

Variante Slide con  
profilo inclinato a 15°

**SOLUZIONI VETRO A SBALZO SPESSORE ANTA 80/92**

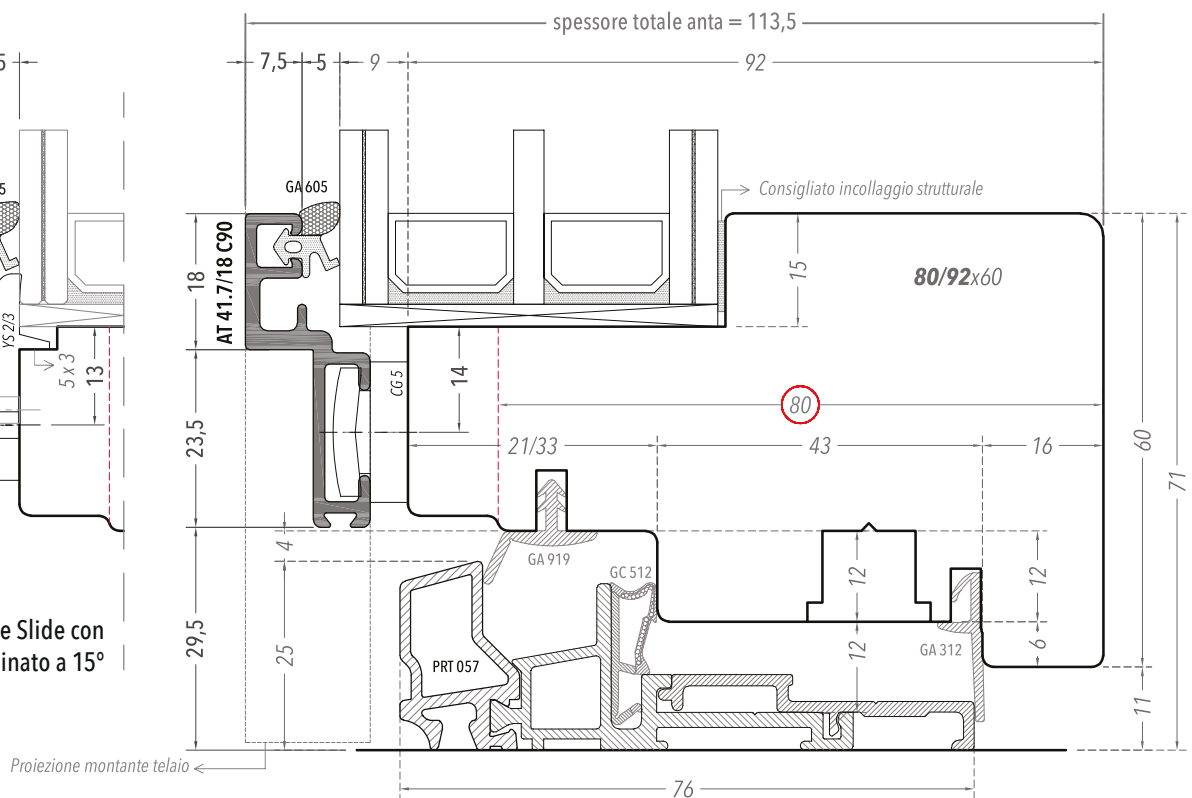





Spessore telaio 65  
Spessore anta 68

# Alumfast Orizon

---

STANDARD

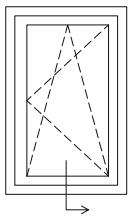

**FINESTRA**

SEZIONE VERTICALE  
NODO INFERIORE  
SCALA 1:1

Variante Slide con  
profilo inclinato a 15°  
e vetro a filo

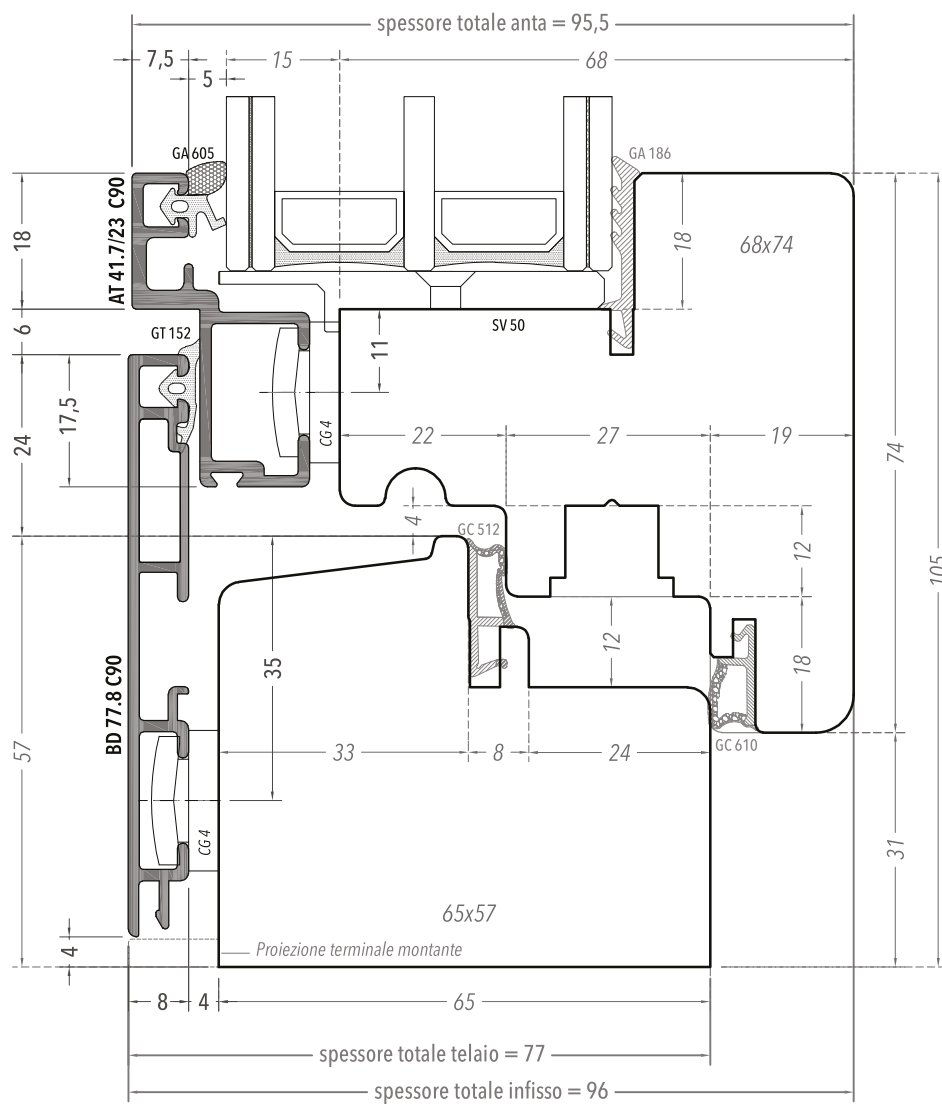
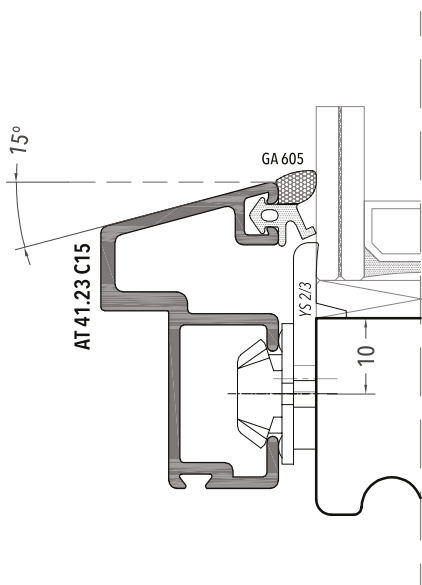

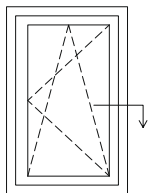

**FINESTRA**

SEZIONE ORIZZONTALE  
 NODO LATERALE  
 SCALA 1:1

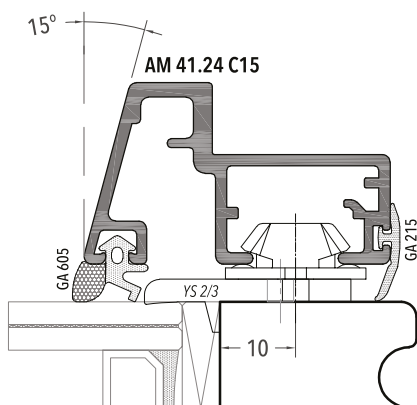

Variante Slide con  
 profilo inclinato a 15°  
 e vetro a filo

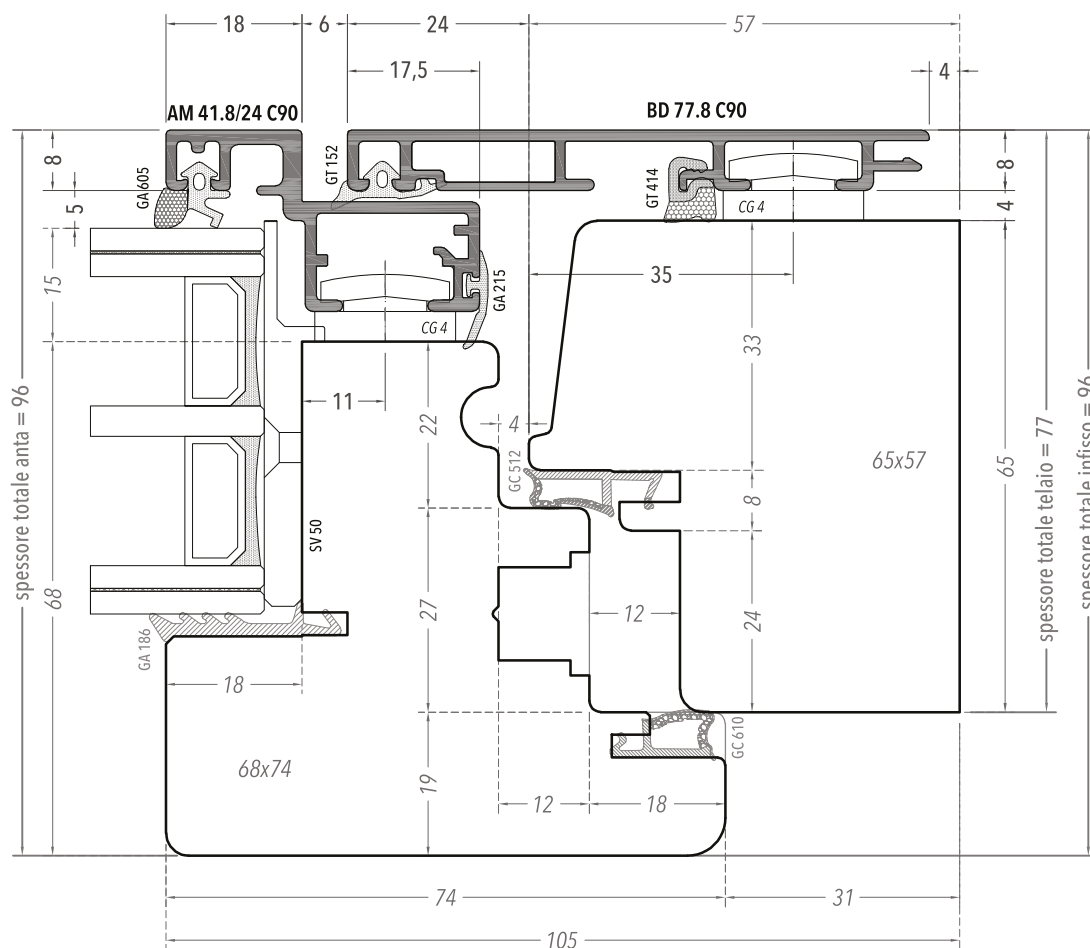

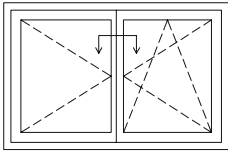

**FINESTRA**

SEZIONE ORIZZONTALE  
NODO CENTRALE  
SCALA 1:1

Variante Slide con profilo inclinato a 15°  
e vetro a filo

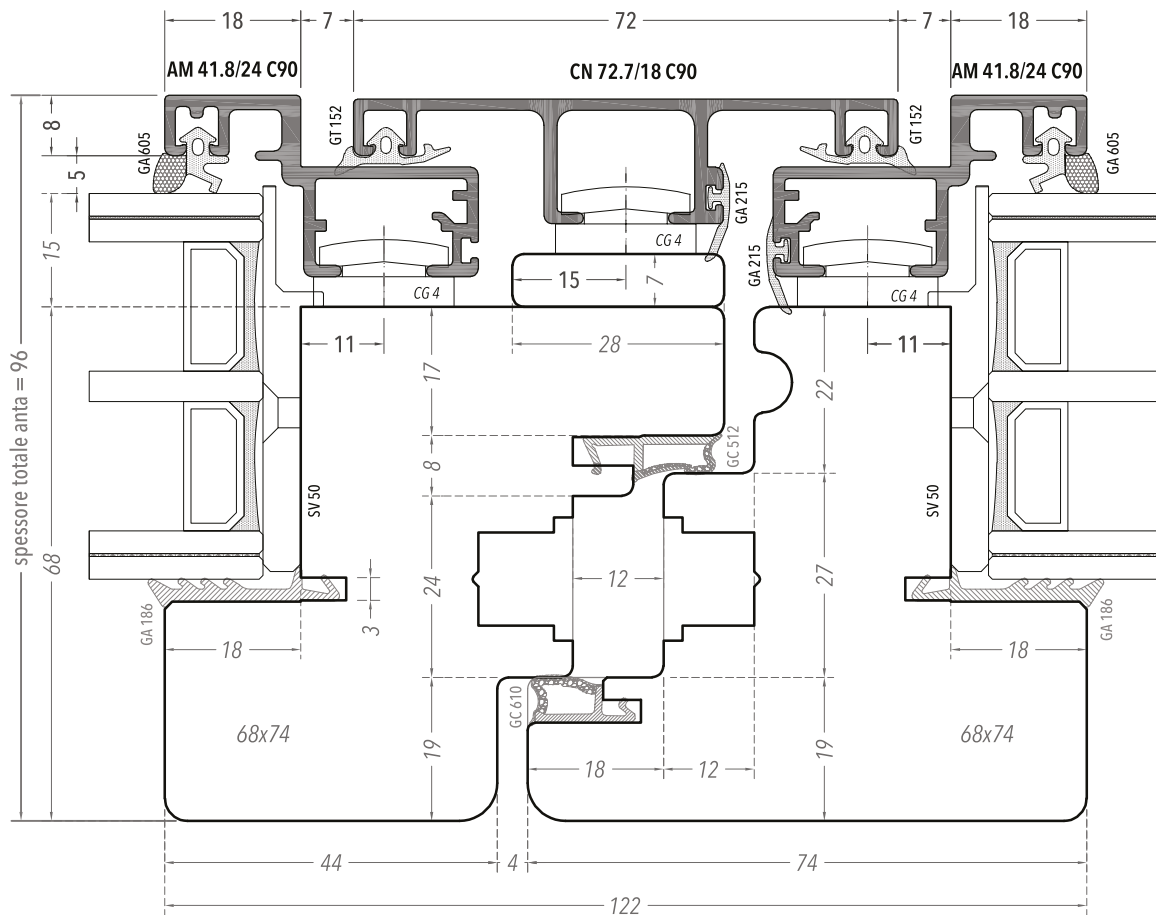
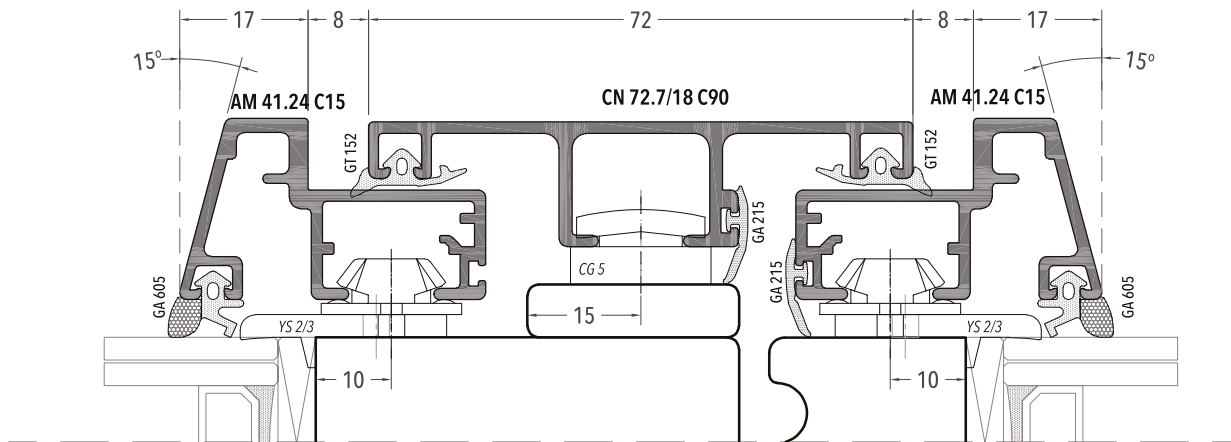



**PORTAFINESTRA**

SEZIONE VERTICALE  
NODO INFERIORE  
SCALA 1:1

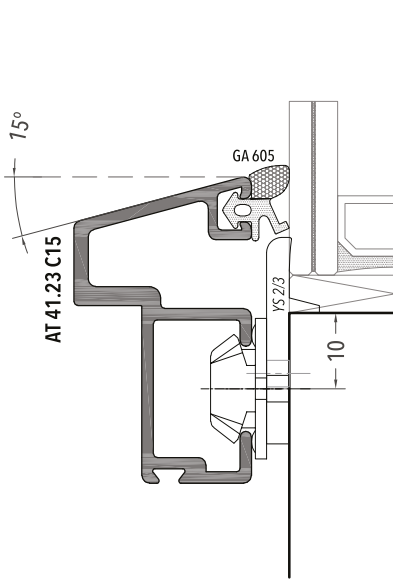
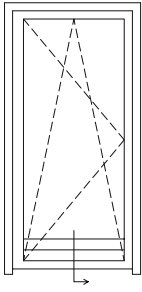

Variante Slide con  
profilo inclinato a 15°  
e vetro a filo

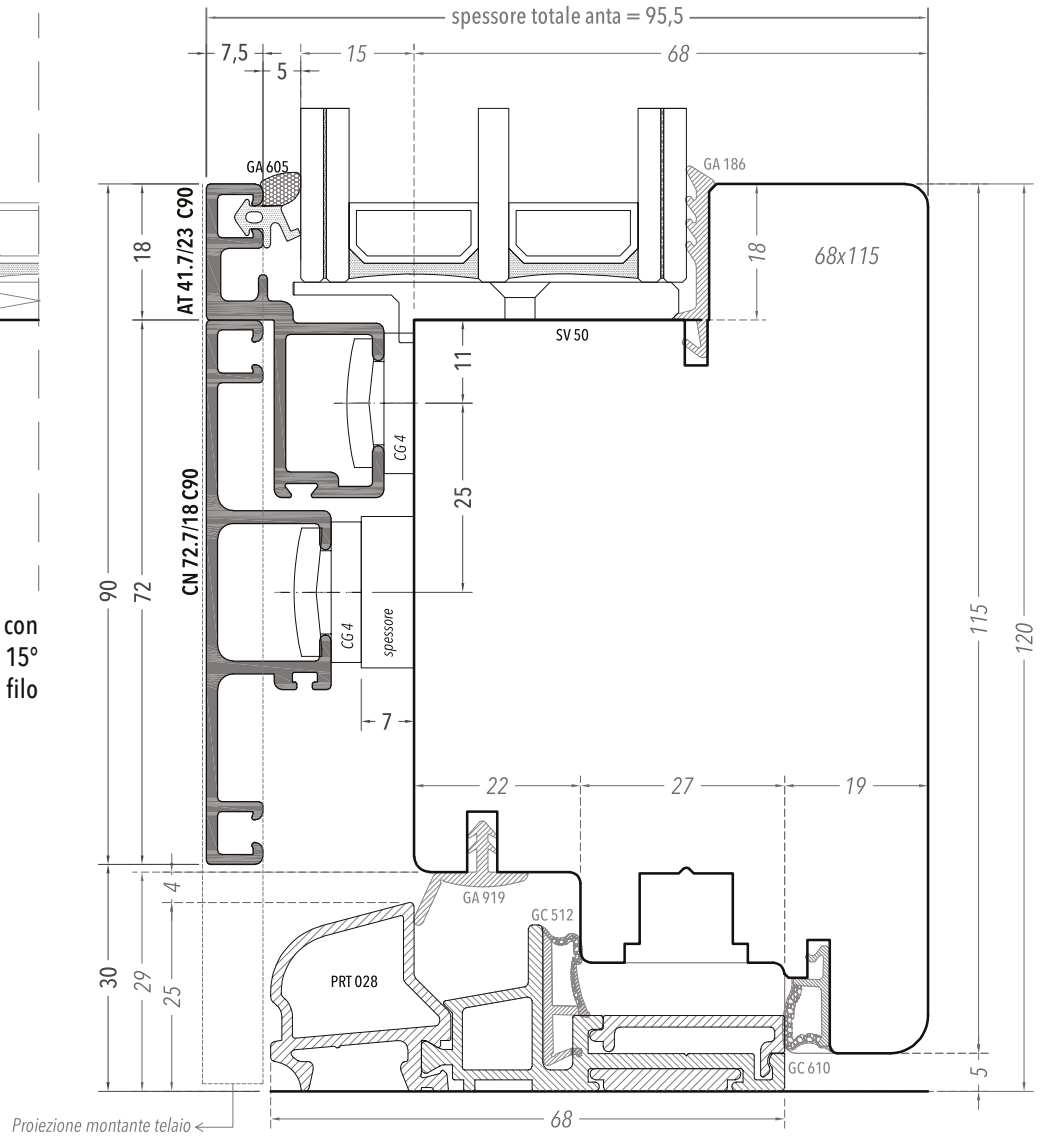

**PORTAFINESTRA CON SERRATURA PASSANTE**

SEZIONE ORIZZONTALE  
 NODO LATERALE  
 SCALA 1:1

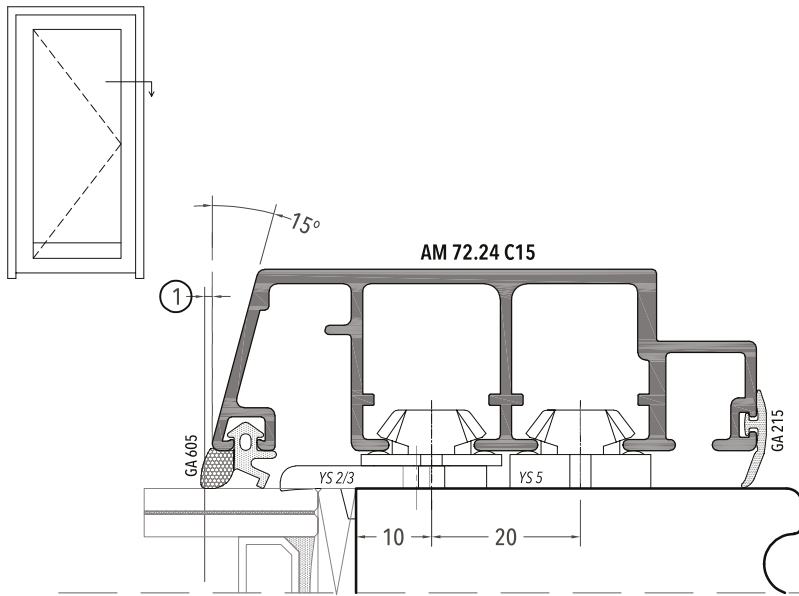

Variante Slide con profilo inclinato a 15°  
 e vetro a filo

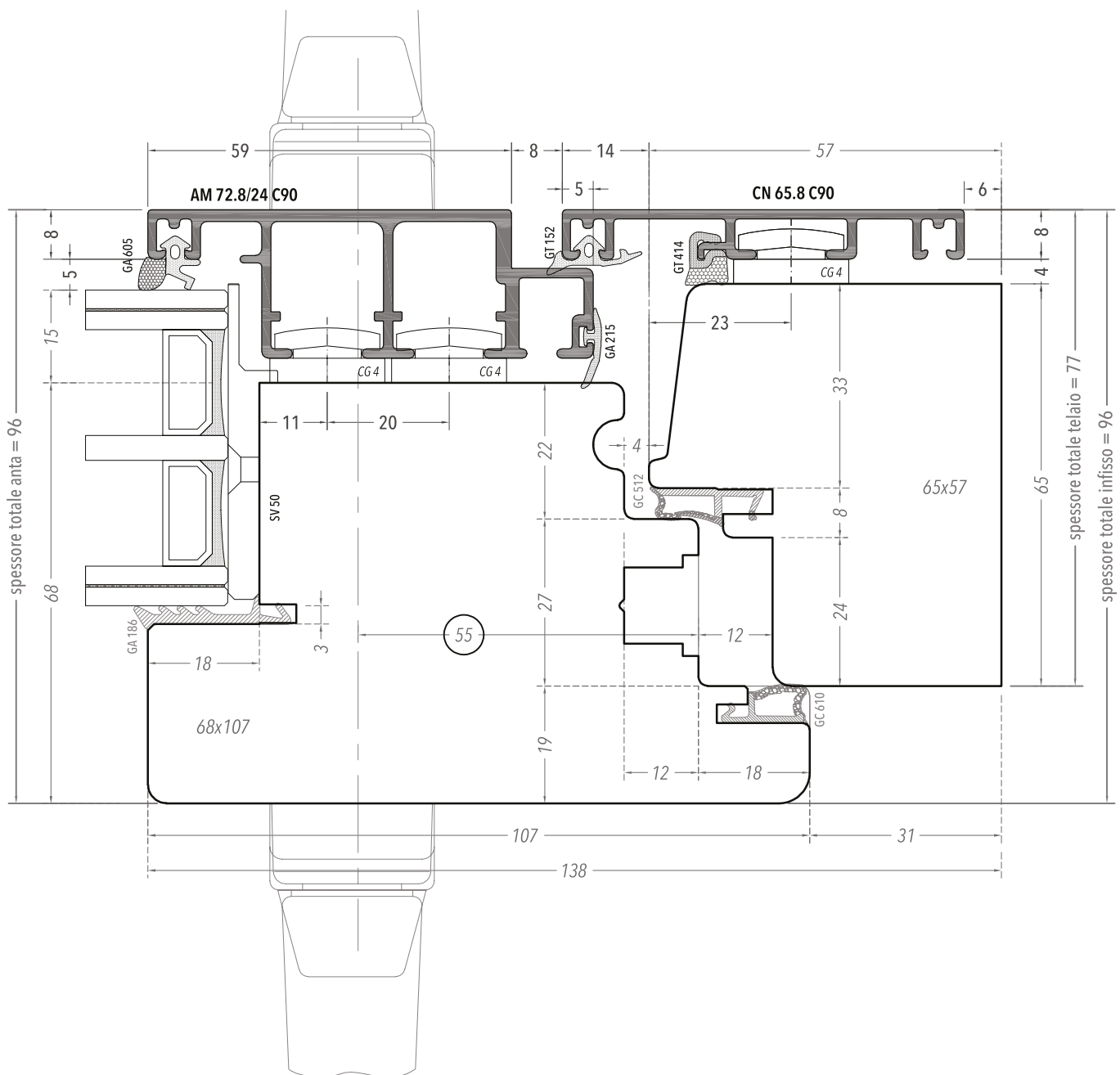

Entrata consigliata per la serratura: 55 mm.

**PORTAFINESTRA CON SERRATURA PASSANTE**

SEZIONE VERTICALE  
NODO SUPERIORE  
SCALA 1:1

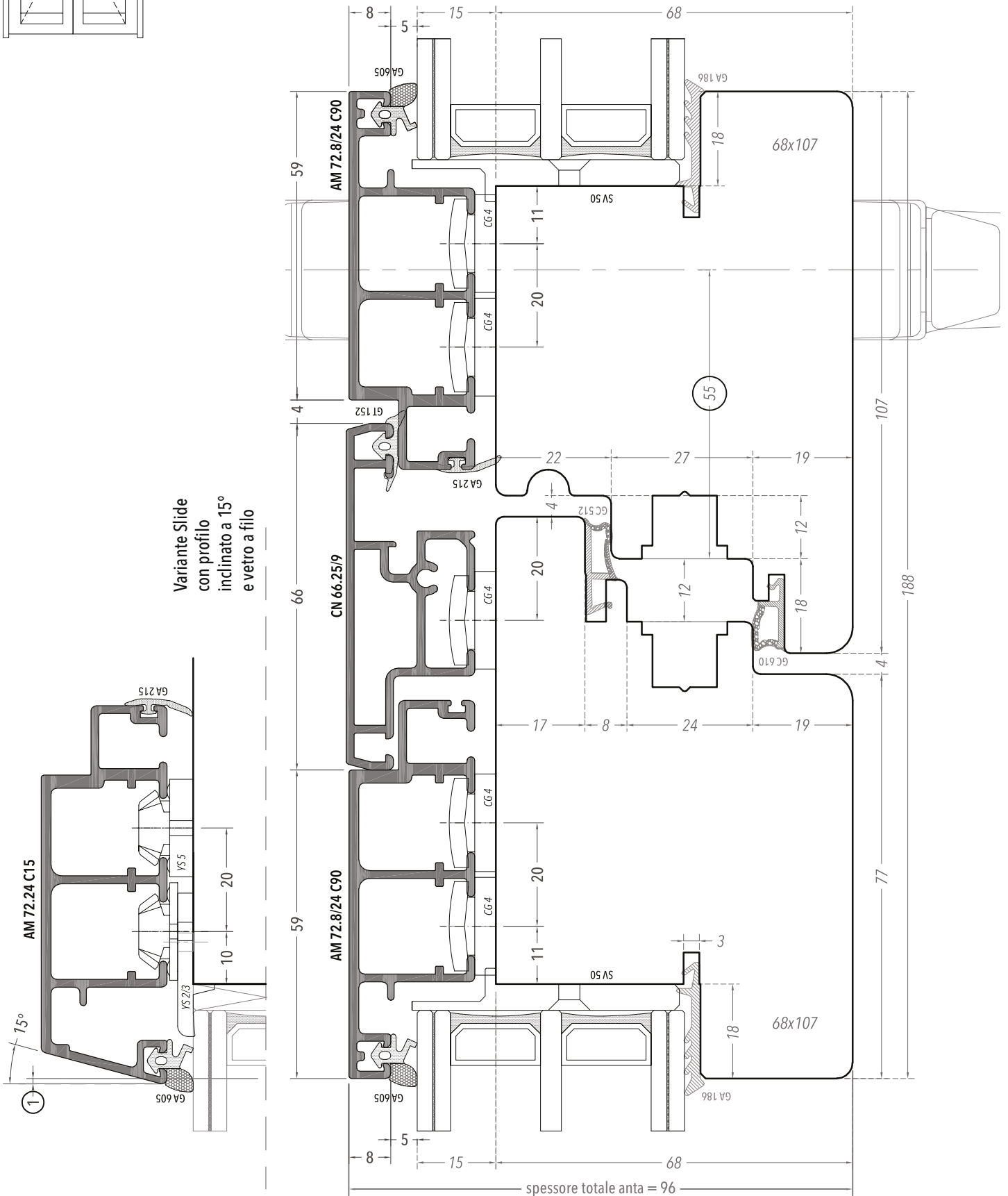
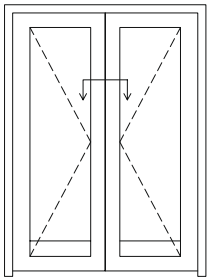

Variante Slide  
con profilo  
inclinato a 15°  
e vetro a filo

In caso di serratura passante, è possibile maggiorare solo il montante con la maniglia e lasciare invariata la sezione anta sugli altri lati.  
Entrata consigliata per la serratura: 55 mm.

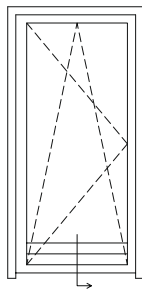

**PORTAFINESTRA CON SERRATURA PASSANTE**

SEZIONE VERTICALE  
NODO INFERIORE  
SCALA 1:1

Variante Slide  
con profilo  
inclinato a 15°  
e vetro a filo

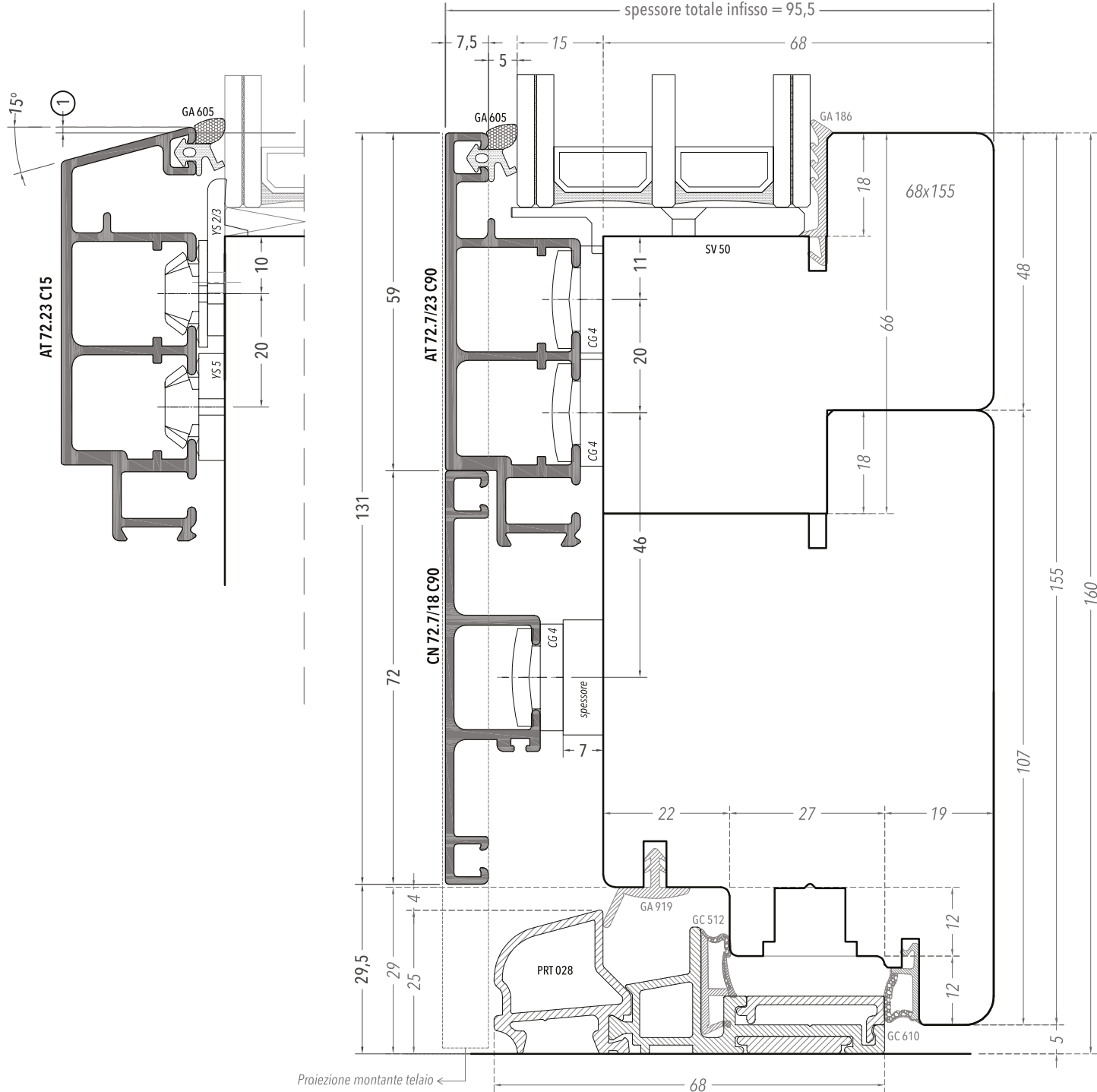





Spessore telaio 58  
Spessore anta 68

# Alumfast Orizon

---

SLIM

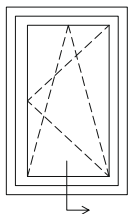

**FINESTRA**

SEZIONE VERTICALE  
NODO INFERIORE  
SCALA 1:1

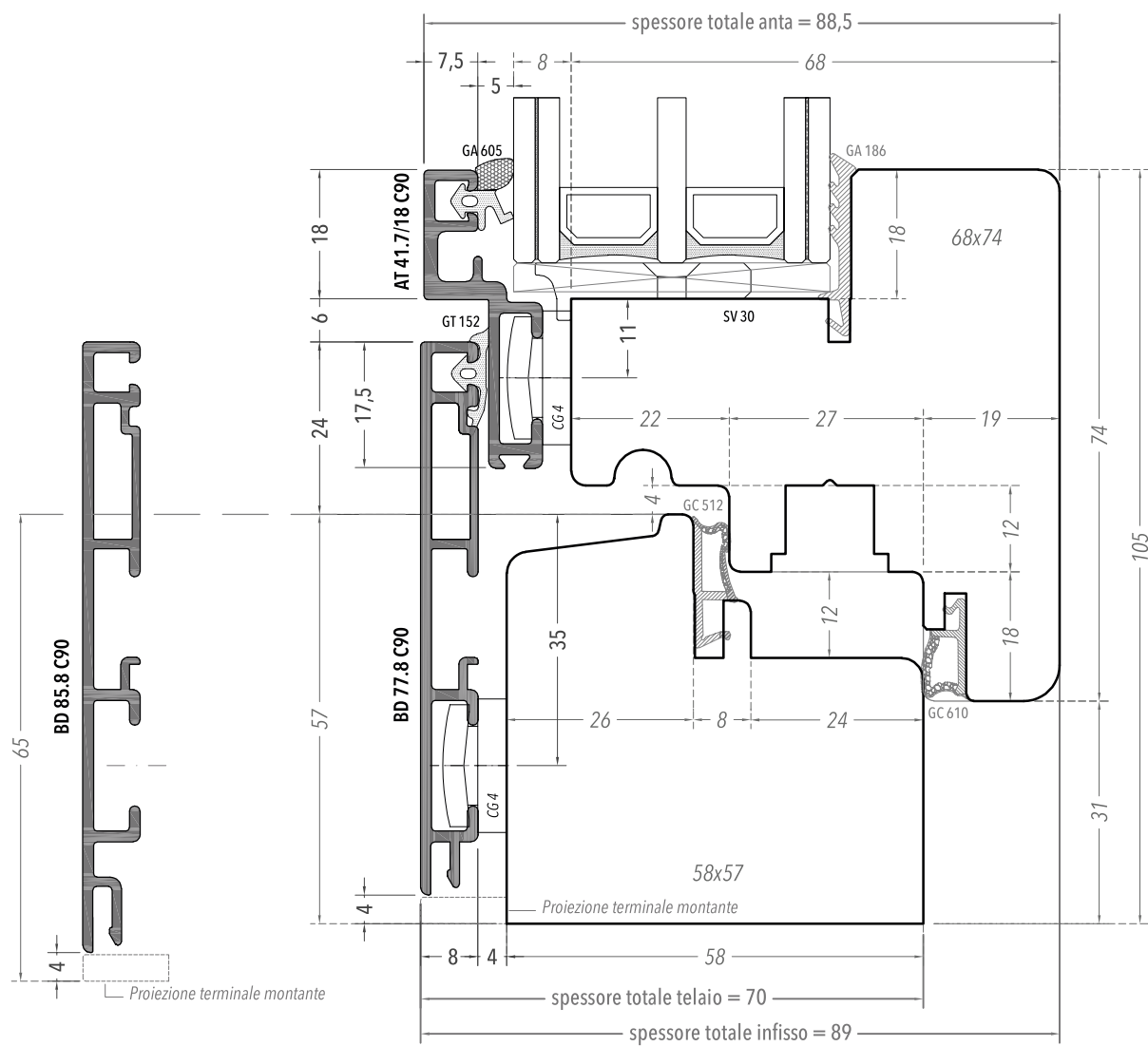



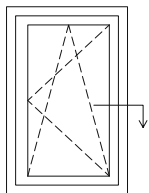

**FINESTRA**

SEZIONE ORIZZONTALE  
 NODO LATERALE  
 SCALA 1:1

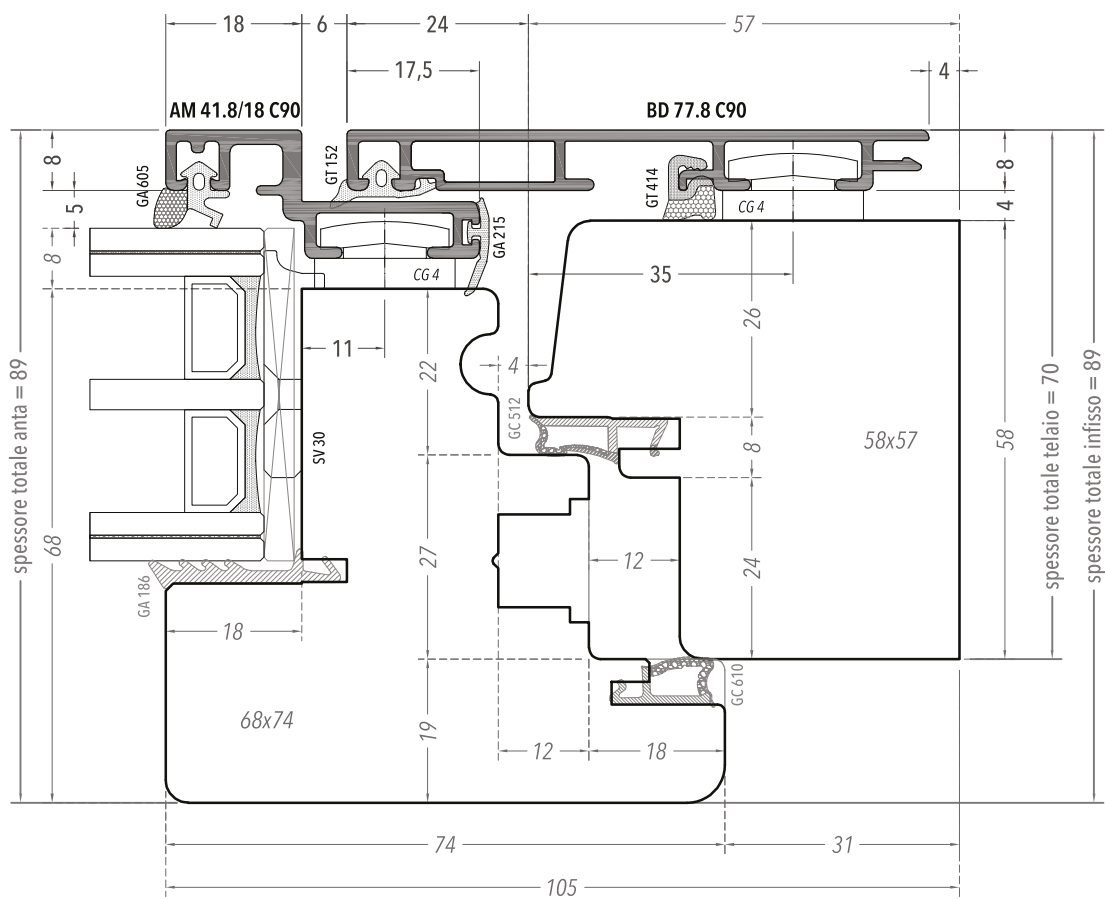

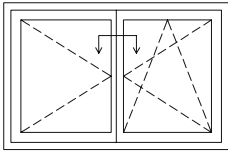

**FINESTRA**

SEZIONE ORIZZONTALE  
 NODO CENTRALE  
 SCALA 1:1

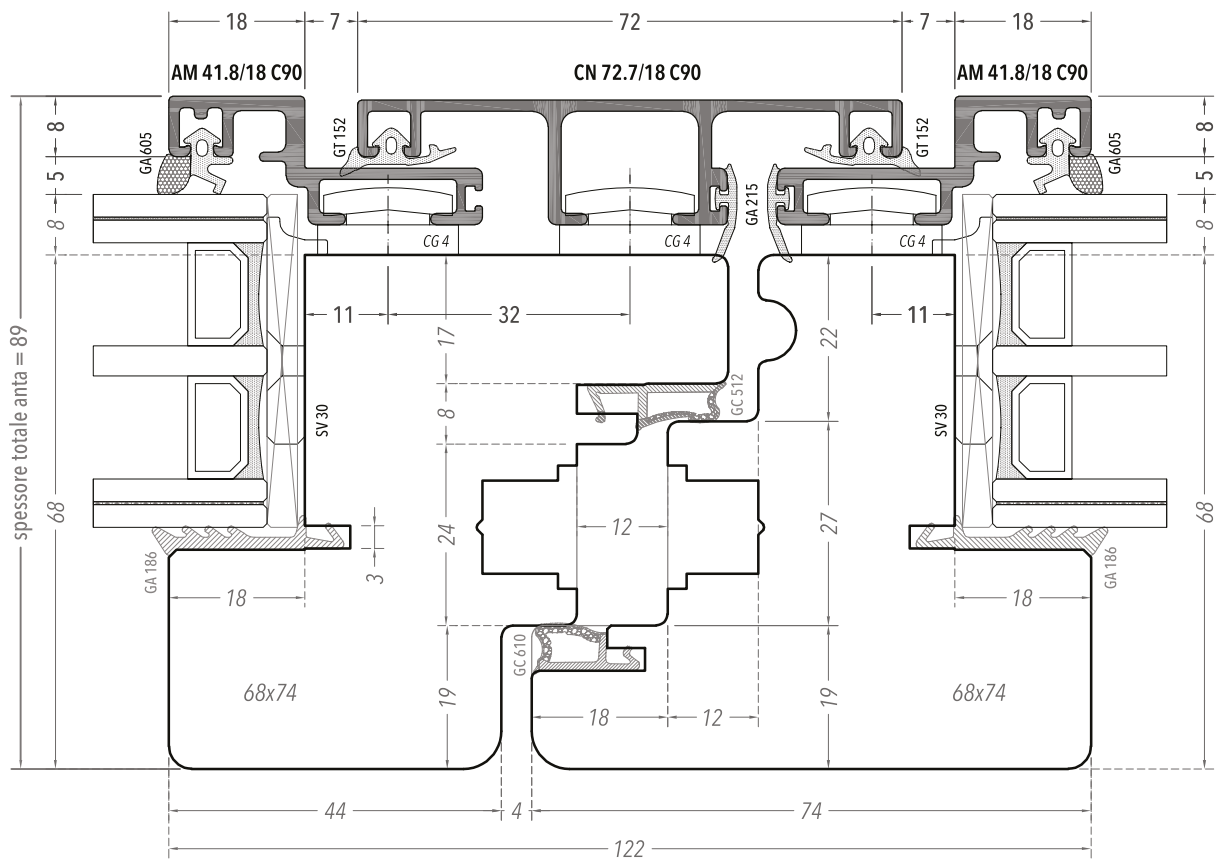

**PORTAFINESTRA**

SEZIONE VERTICALE  
NODO INFERIORE  
SCALA 1:1

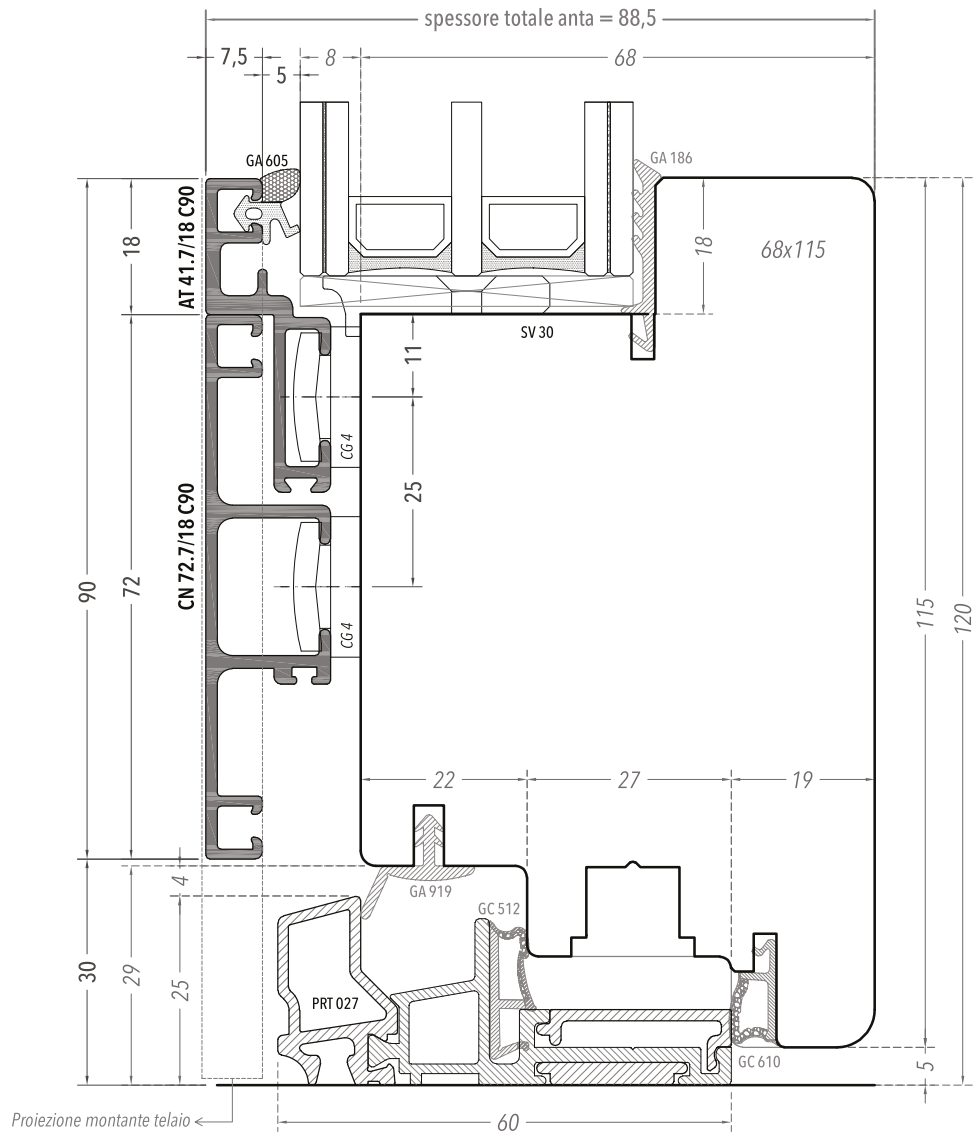
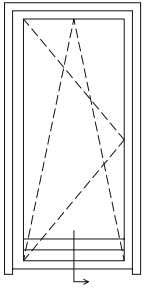

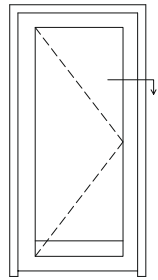

# PORTAFINESTRA CON SERRATURA PASSANTE

SEZIONE ORIZZONTALE  
NODO LATERALE  
SCALA 1:1

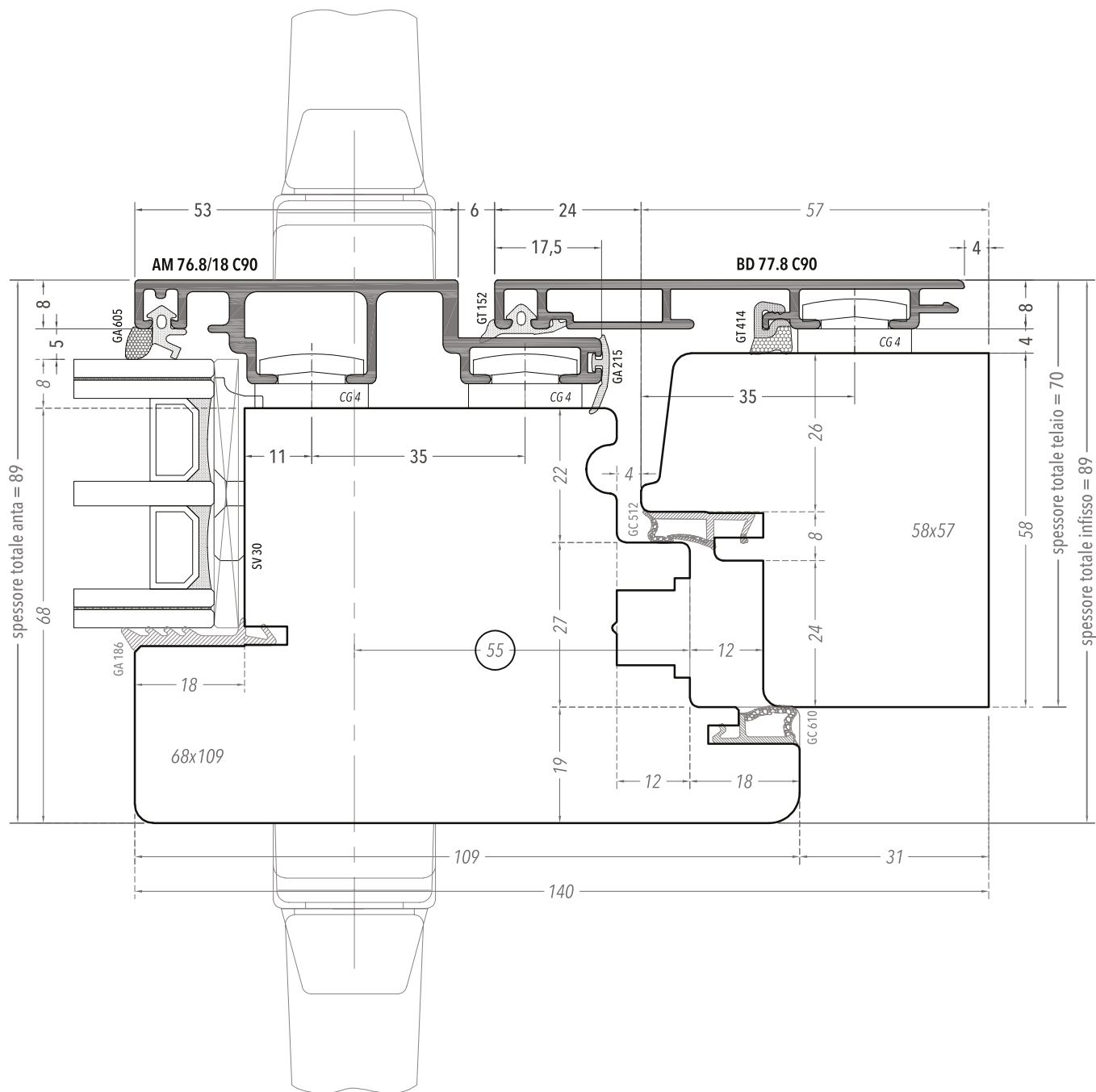

In caso di serratura passante, è possibile maggiorare solo il montante con la maniglia e lasciare invariata la sezione anta sugli altri lati.  
Entrata consigliata per la serratura: 55 mm.

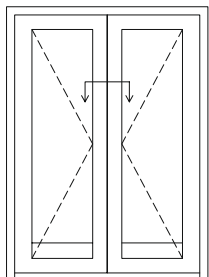

**PORTAFINESTRA CON SERRATURA PASSANTE**

SEZIONE ORIZZONTALE  
NODO CENTRALE  
SCALA 1:1

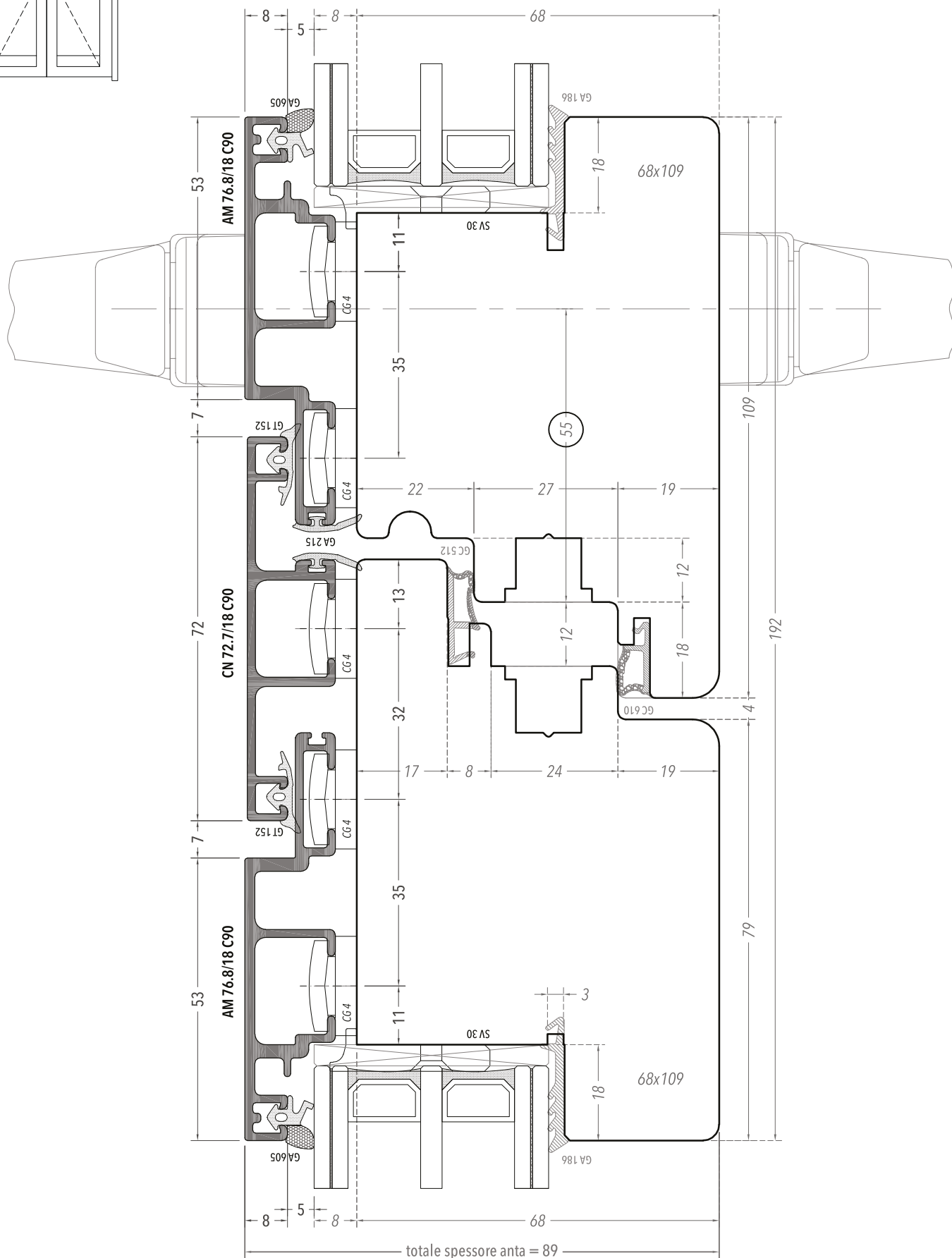

In caso di serratura passante, è possibile maggiorare solo il montante con la maniglia e lasciare invariata la sezione anta sugli altri lati.  
Entrata consigliata per la serratura: 55 mm.

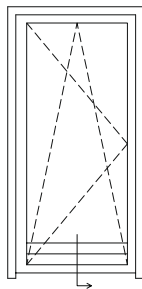

**PORTAFINESTRA CON SERRATURA PASSANTE**

SEZIONE VERTICALE  
 NODO INFERIORE  
 SCALA 1:1

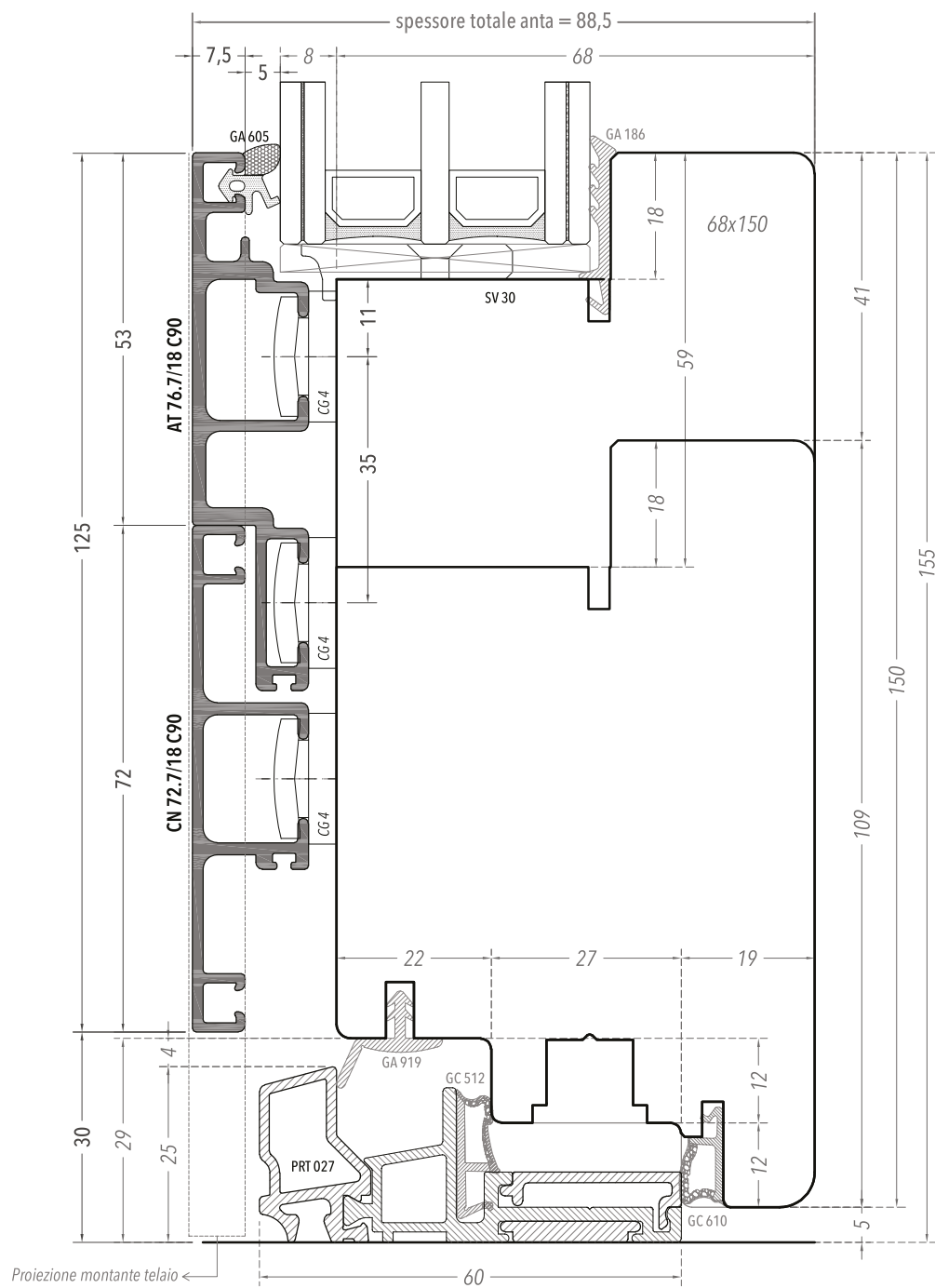





Spessore telaio 58  
Spessore anta 68



# Alumfast Orizon

---

SLIM

VETRO A FILO

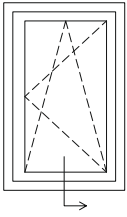

**FINESTRA**

SEZIONE VERTICALE  
NODO INFERIORE  
SCALA 1:1

Variante Slide  
con profilo  
inclinato a 15°

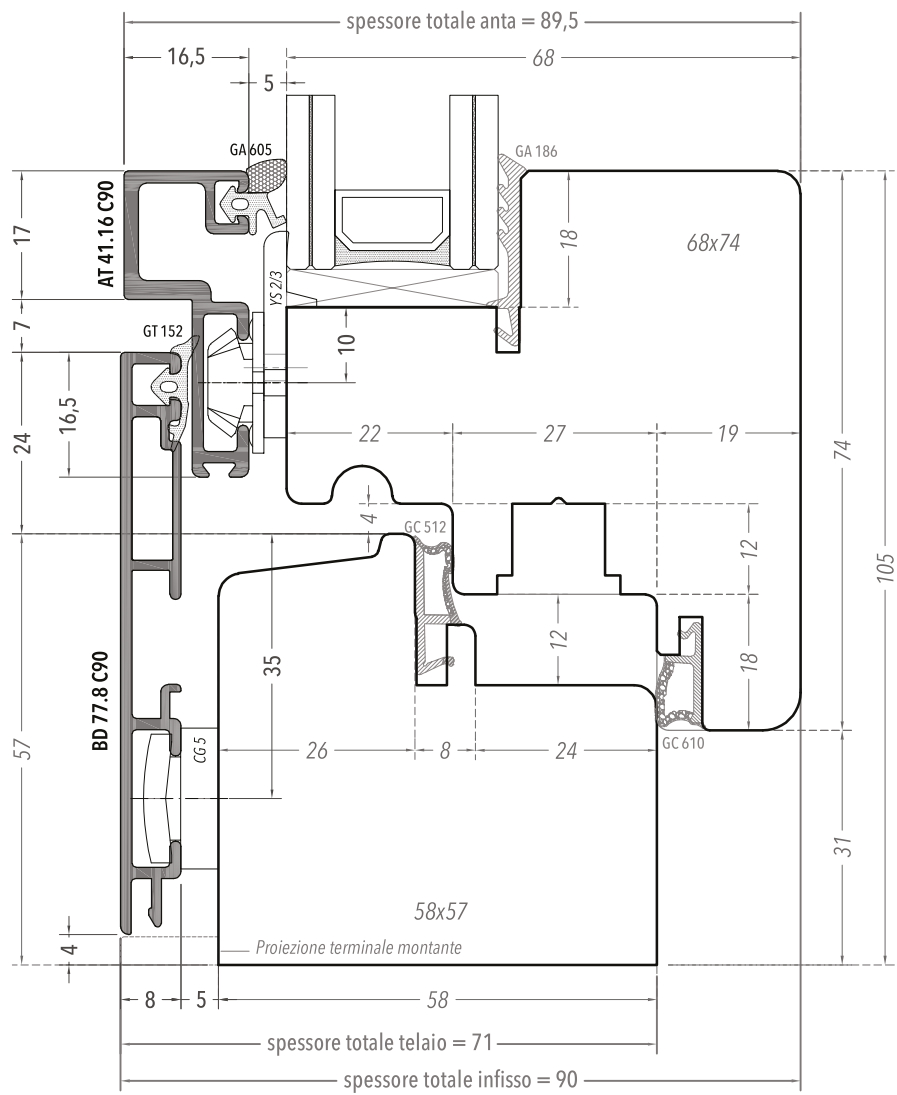
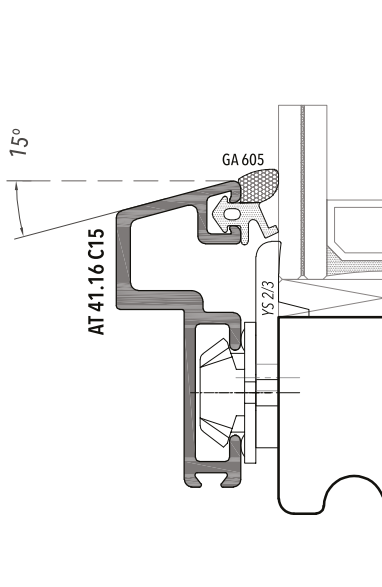

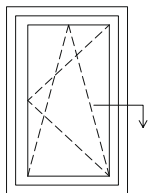

**FINESTRA**

SEZIONE ORIZZONTALE  
 NODO LATERALE  
 SCALA 1:1

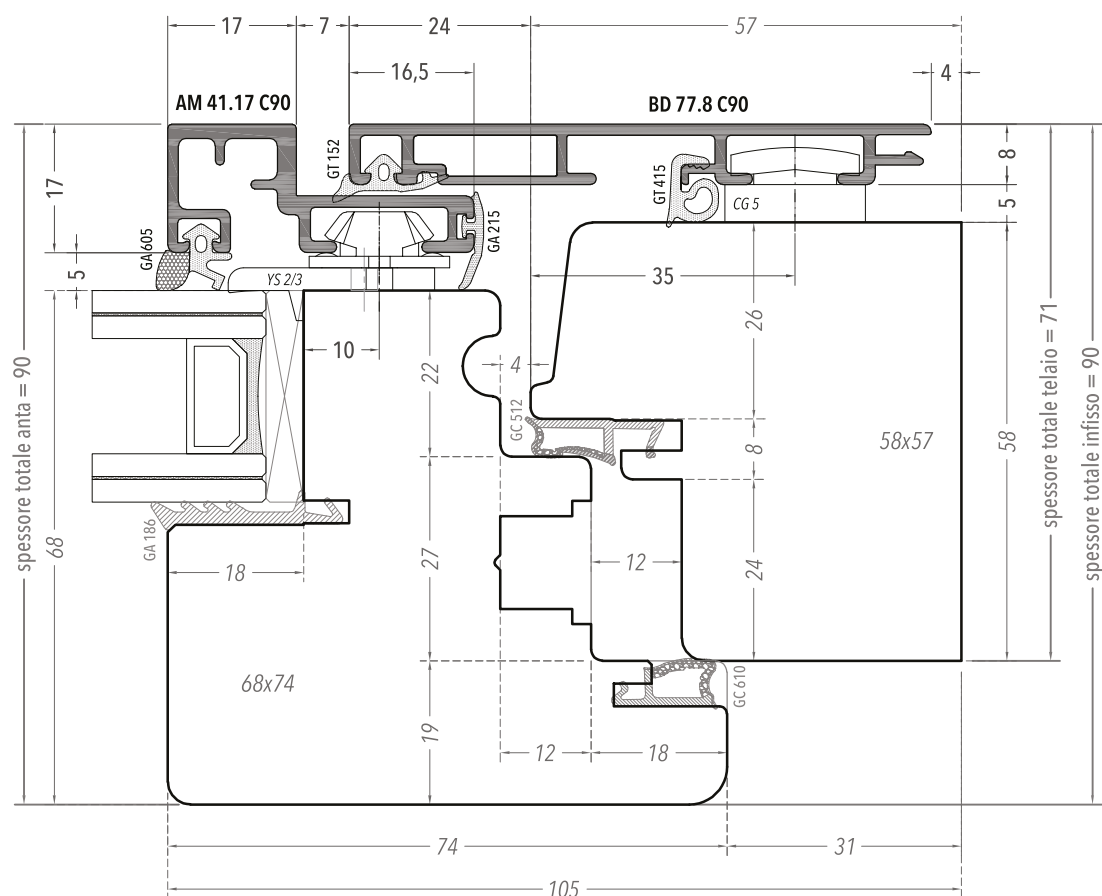
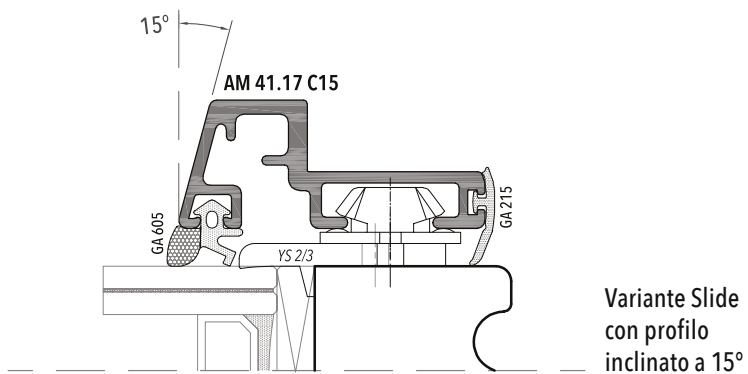

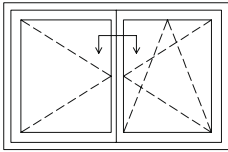

**FINESTRA**

SEZIONE ORIZZONTALE  
NODO CENTRALE  
SCALA 1:1

Variante Slide  
con profilo  
inclinato a 15°

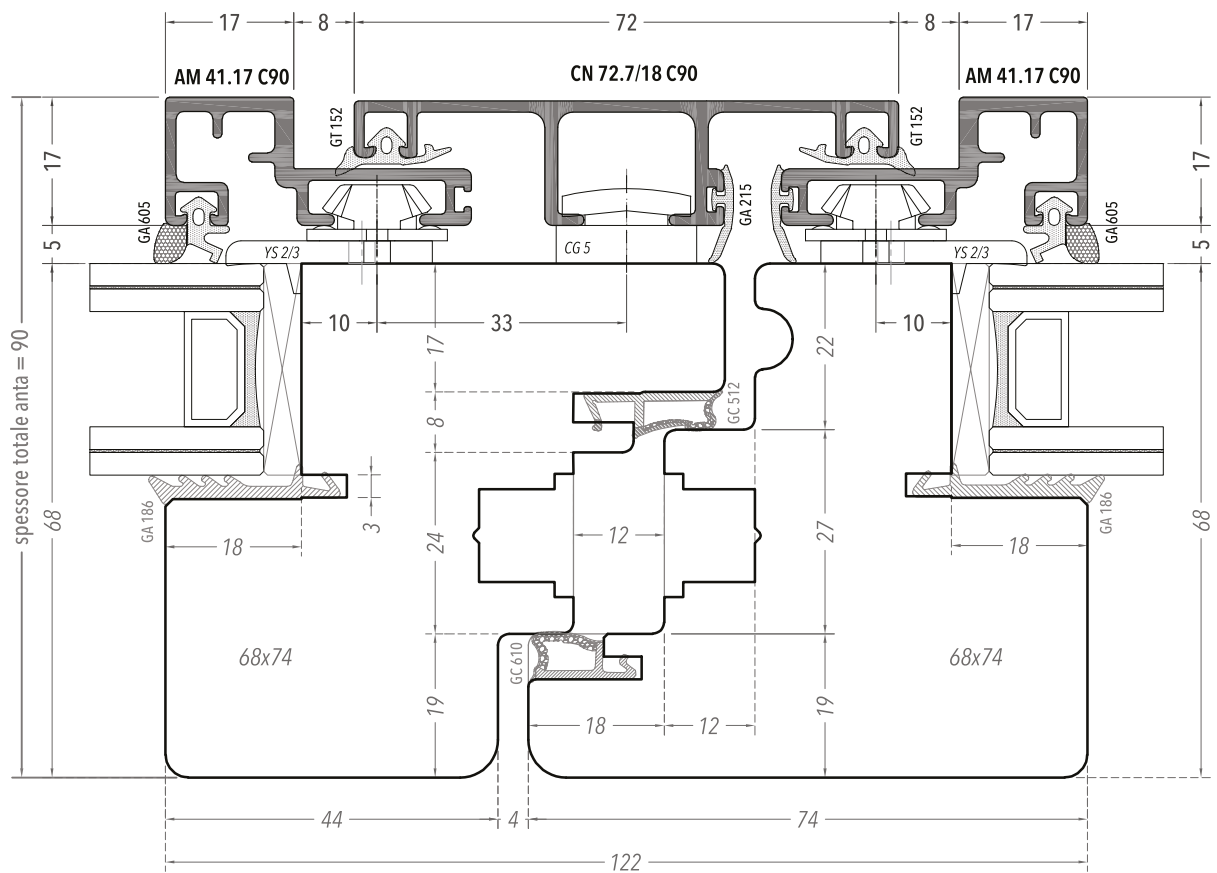
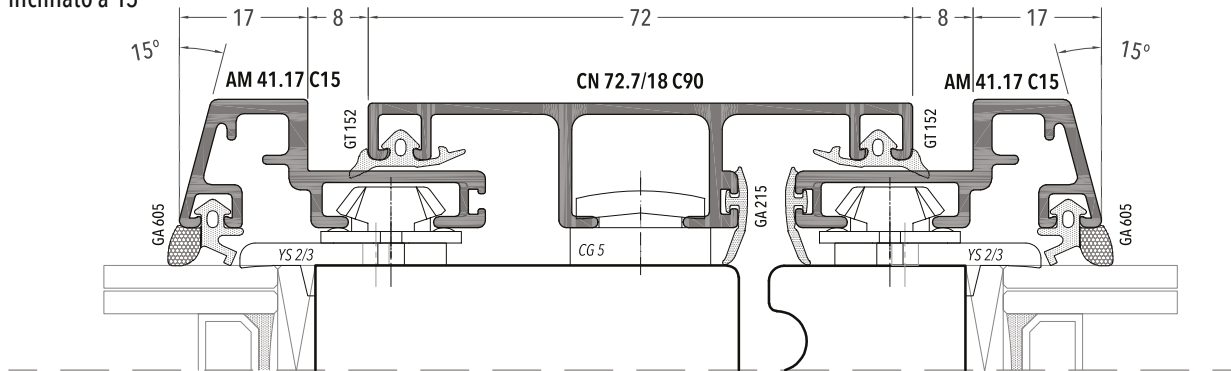

**PORTAFINESTRA**

SEZIONE VERTICALE  
NODO INFERIORE  
SCALA 1:1

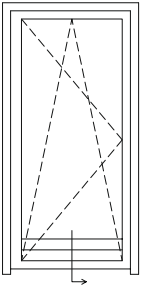

Variante Slide  
con profilo  
inclinato a 15°

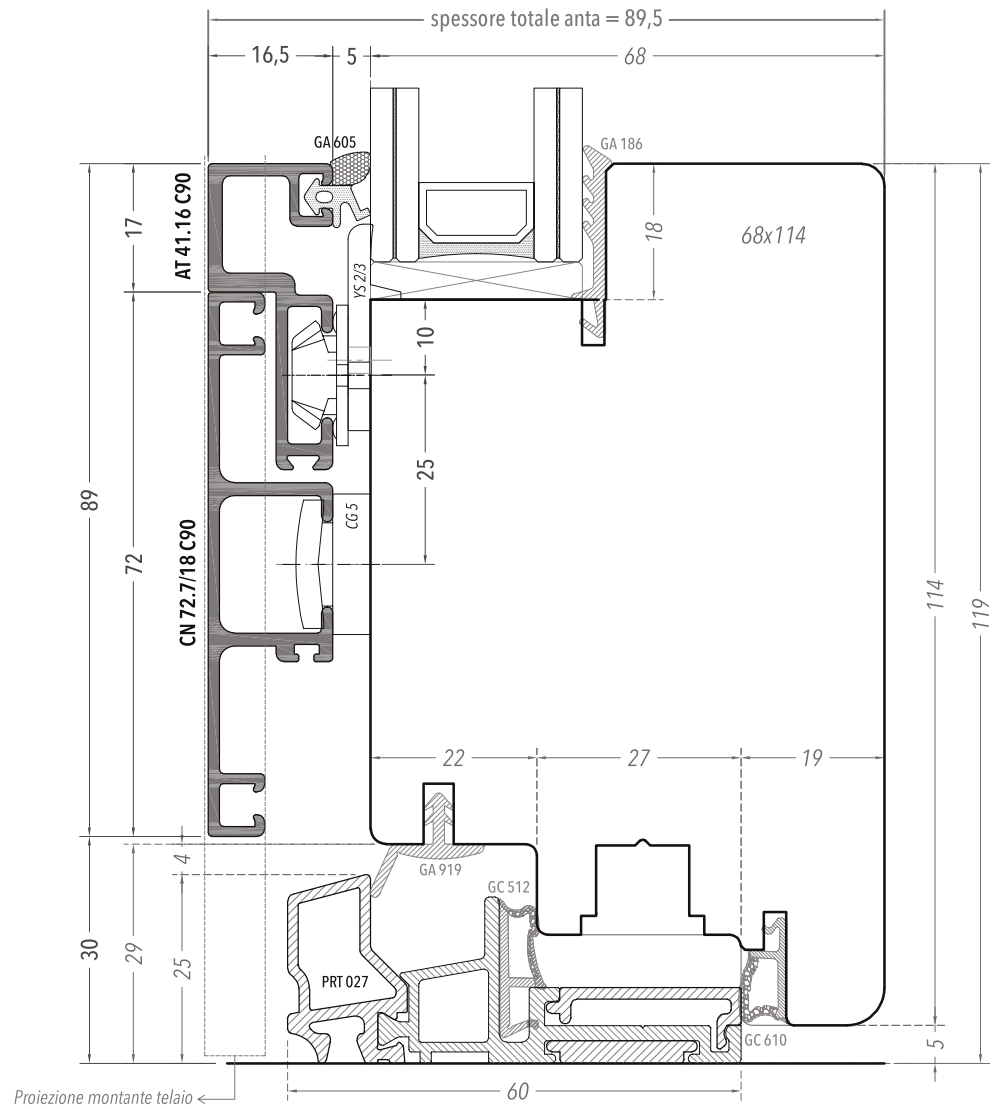
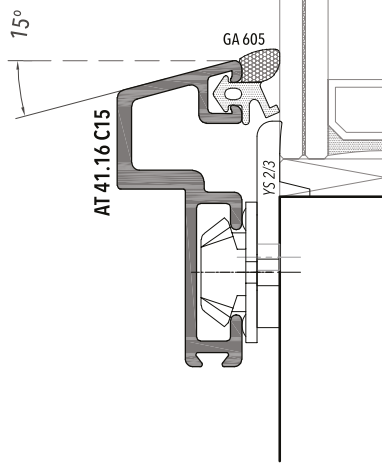



Spessore telaio 77  
Spessore anta 80

# Alumfast Orizon

---

HP80

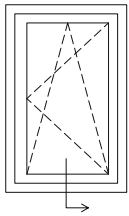

**FINESTRA**

SEZIONE VERTICALE  
NODO INFERIORE  
SCALA 1:1

Variante Slide  
con profilo  
inclinato a 15°  
e vetro a filo

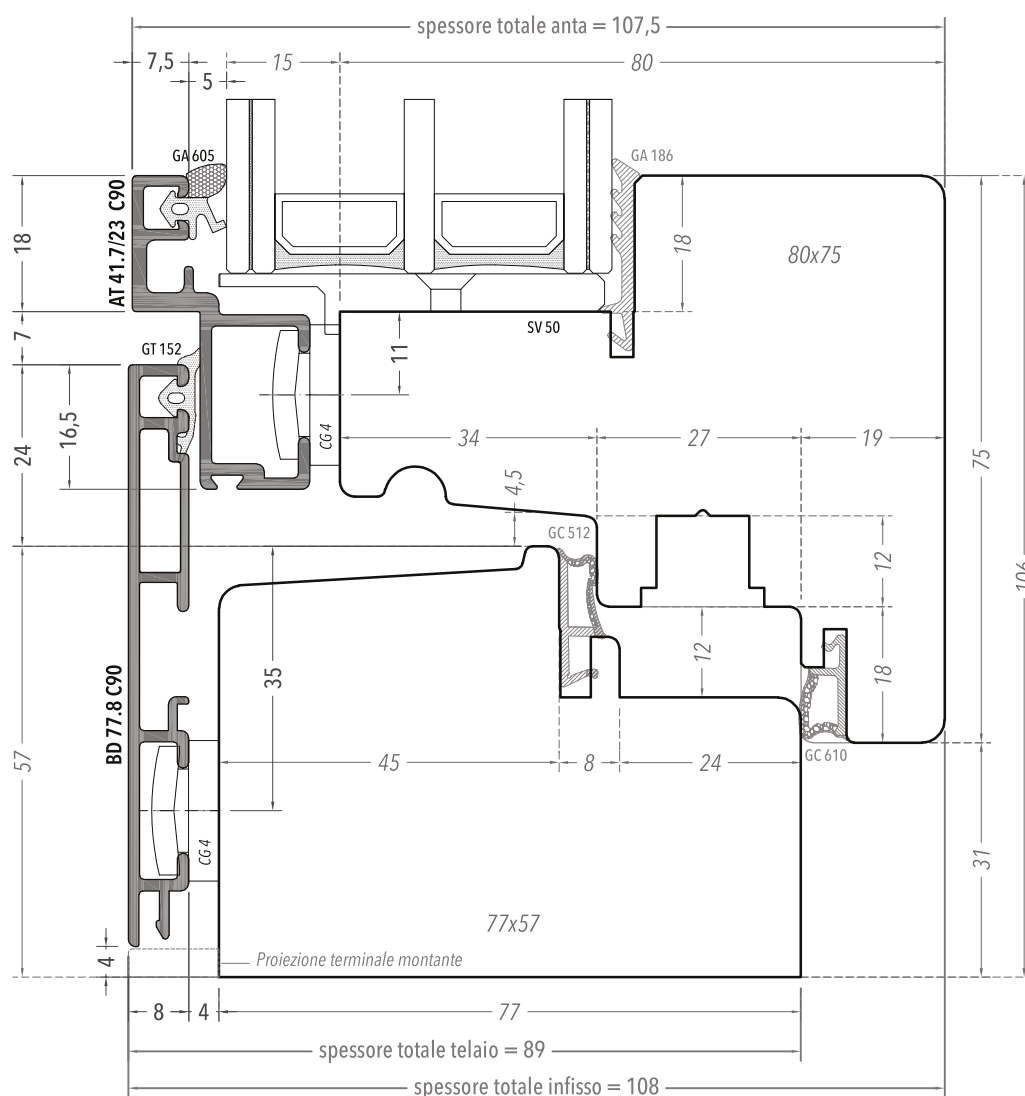
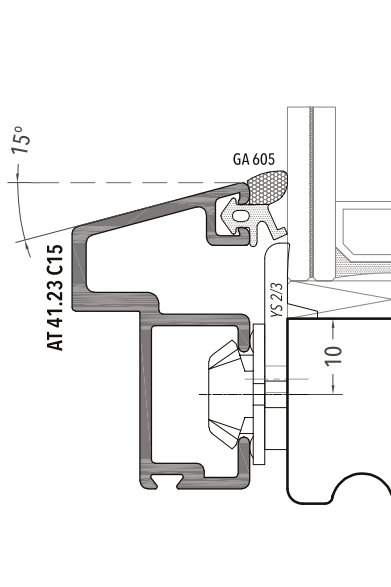



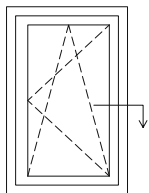

**FINESTRA**

SEZIONE ORIZZONTALE  
 NODO LATERALE  
 SCALA 1:1

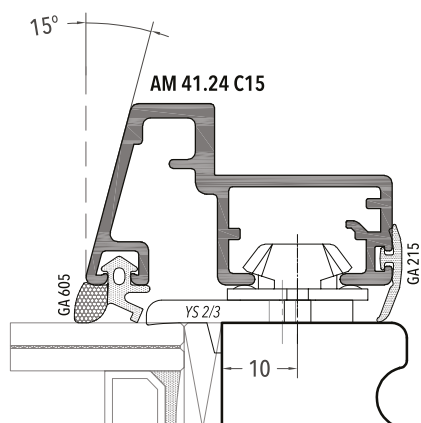

Variante Slide  
 con profilo  
 inclinato a 15°  
 e vetro a filo

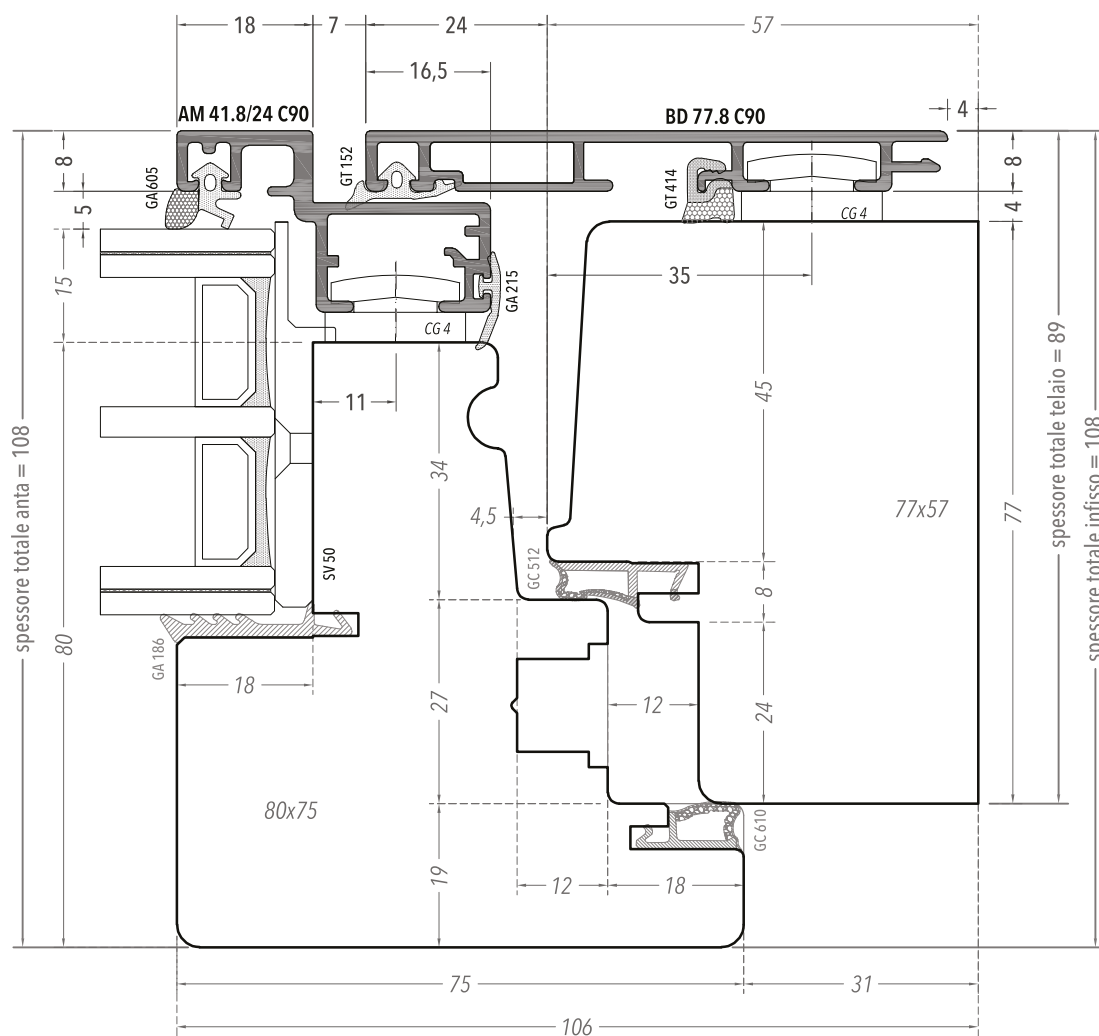

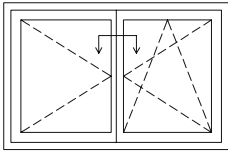

**FINESTRA**

SEZIONE ORIZZONTALE  
 NODO CENTRALE  
 SCALA 1:1

Variante Slide  
 con profilo  
 inclinato a 15°  
 e vetro a filo

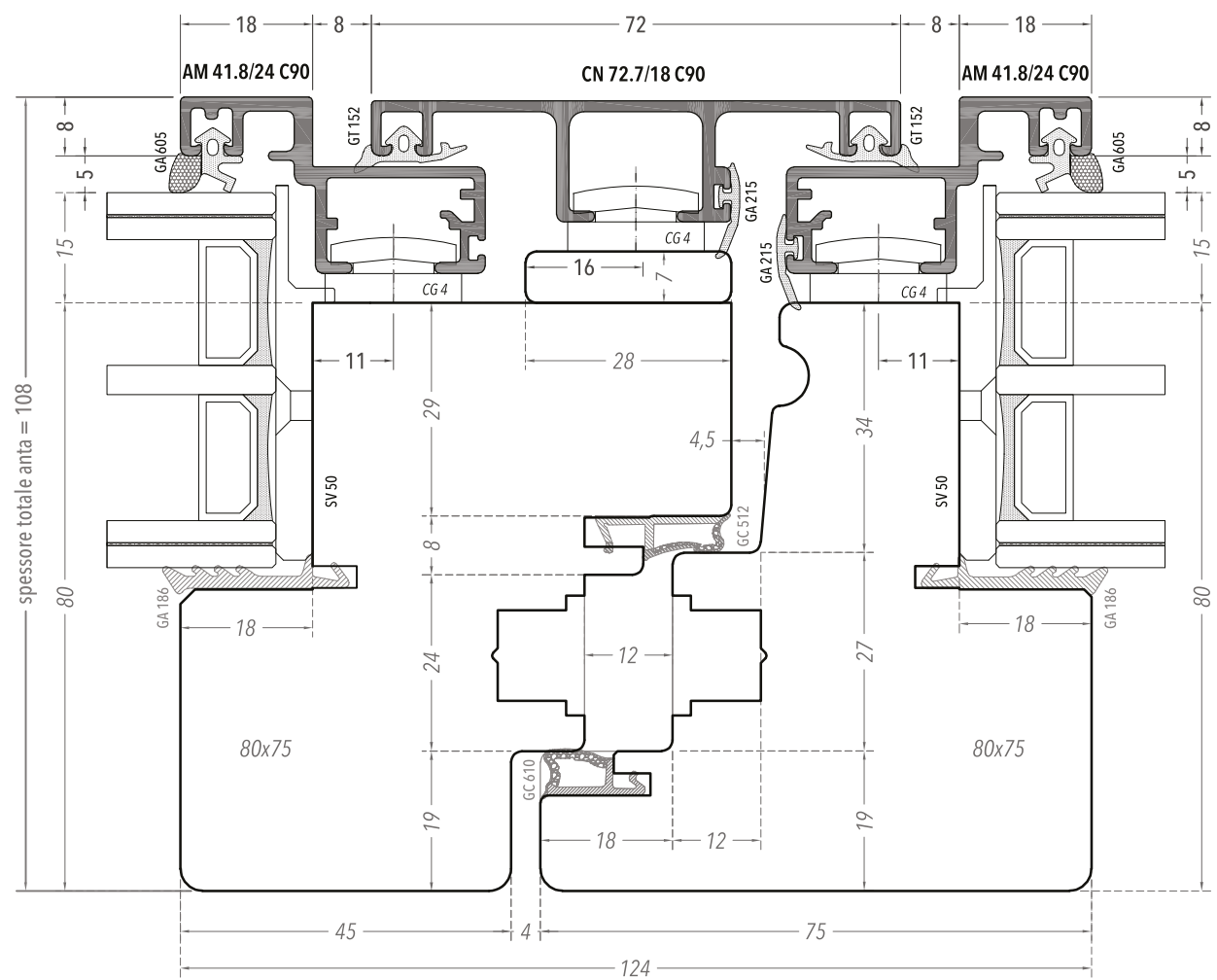
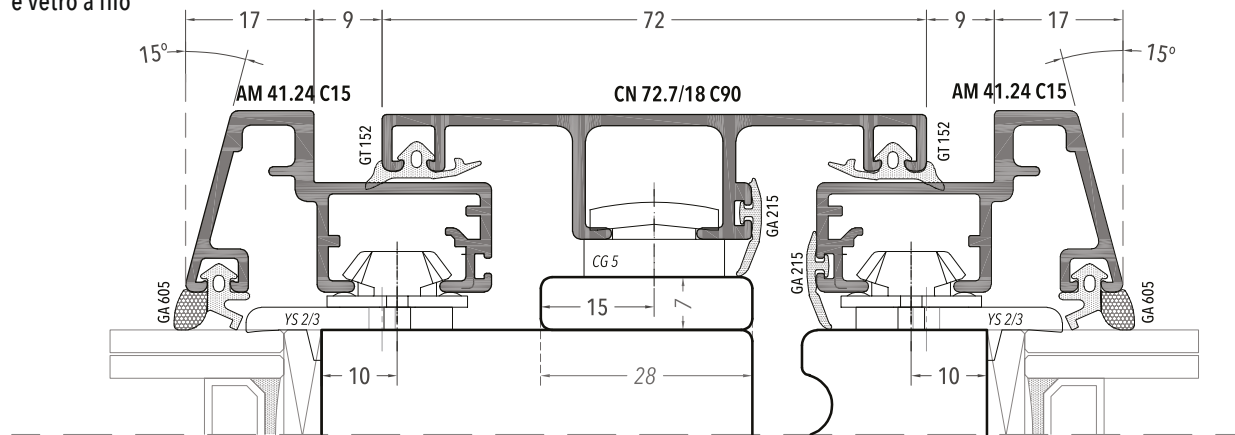

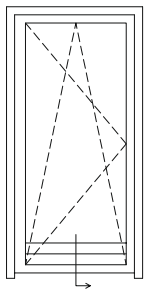

**PORTAFINESTRA**

SEZIONE VERTICALE  
NODO INFERIORE  
SCALA 1:1

Variante Slide  
con profilo  
inclinato a 15°  
e vetro a filo

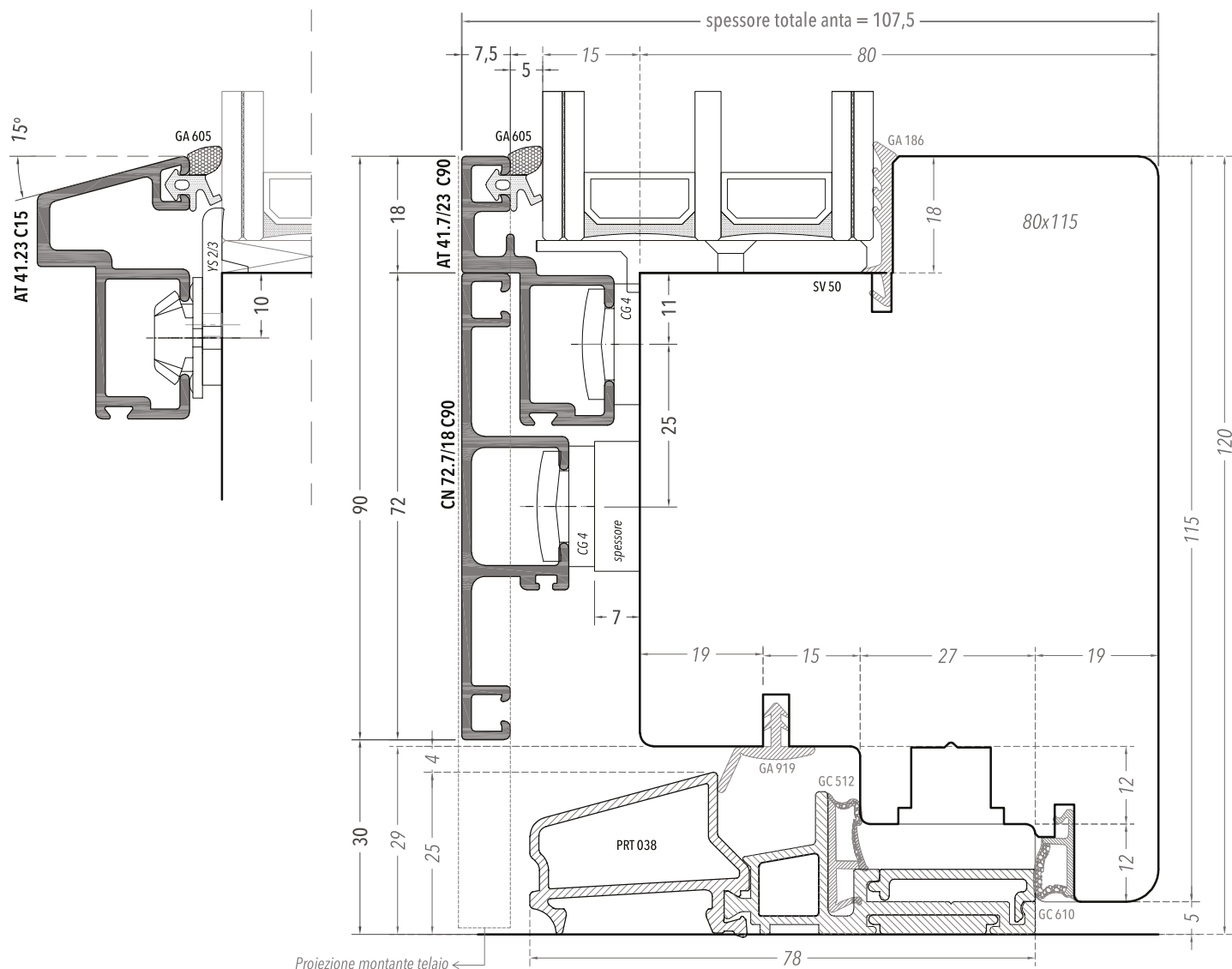



Spessore telaio 70  
Spessore anta 80

# Alumfast Orizon

---

SLIM HP80

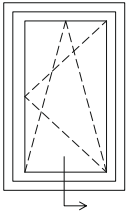

**FINESTRA**

SEZIONE VERTICALE  
 NODO INFERIORE  
 SCALA 1:1

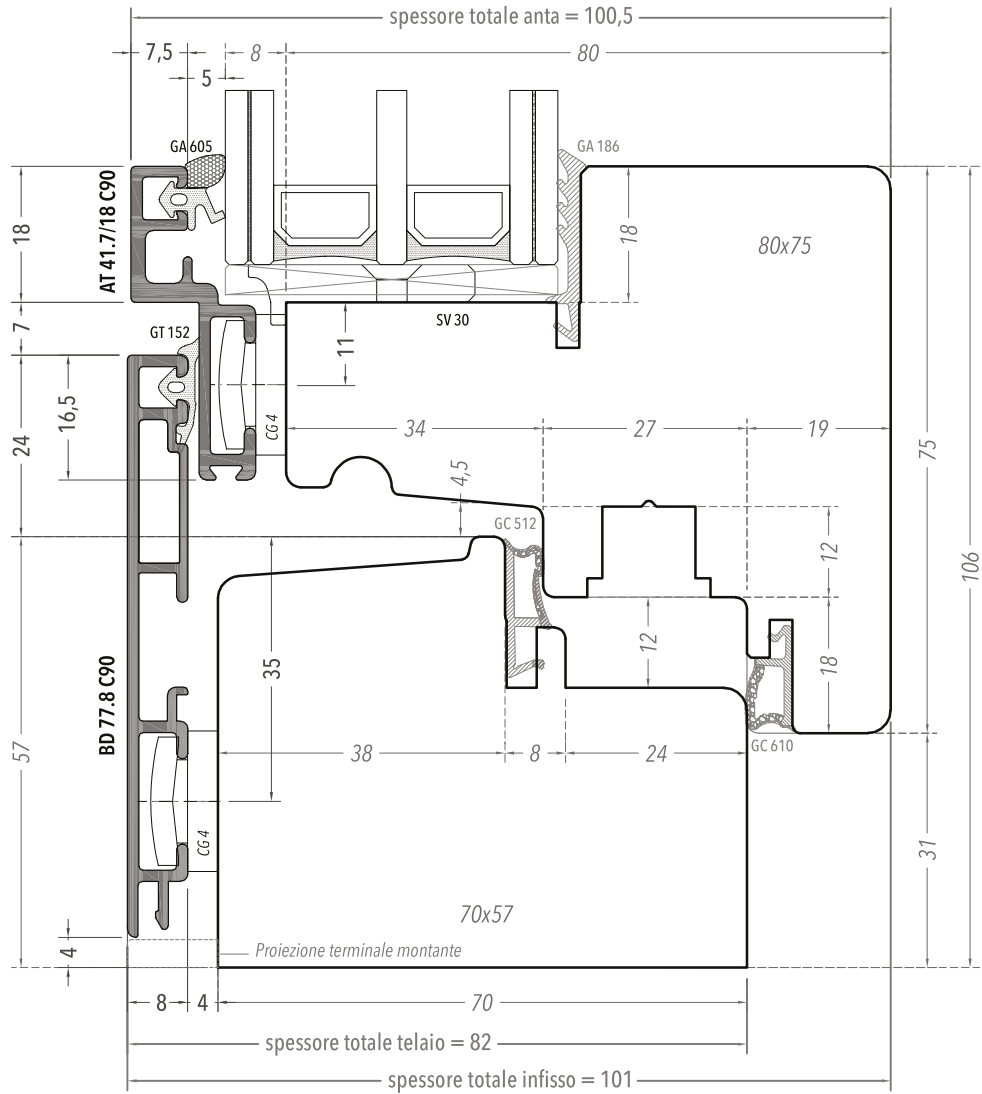

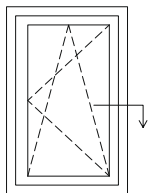

**FINESTRA**

SEZIONE ORIZZONTALE  
 NODO LATERALE  
 SCALA 1:1

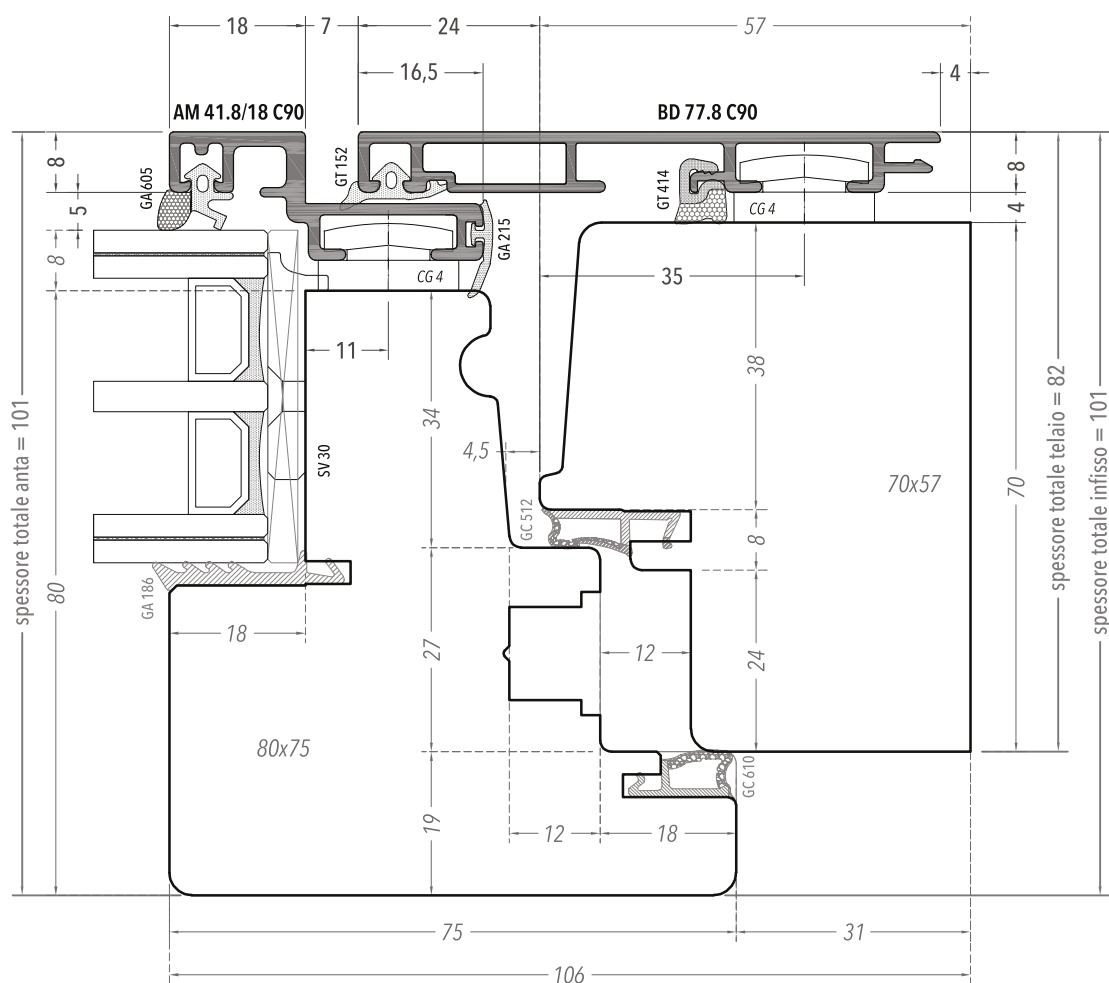

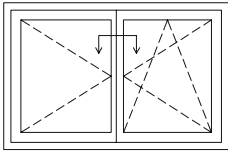

**FINESTRA**

SEZIONE ORIZZONTALE  
 NODO CENTRALE  
 SCALA 1:1

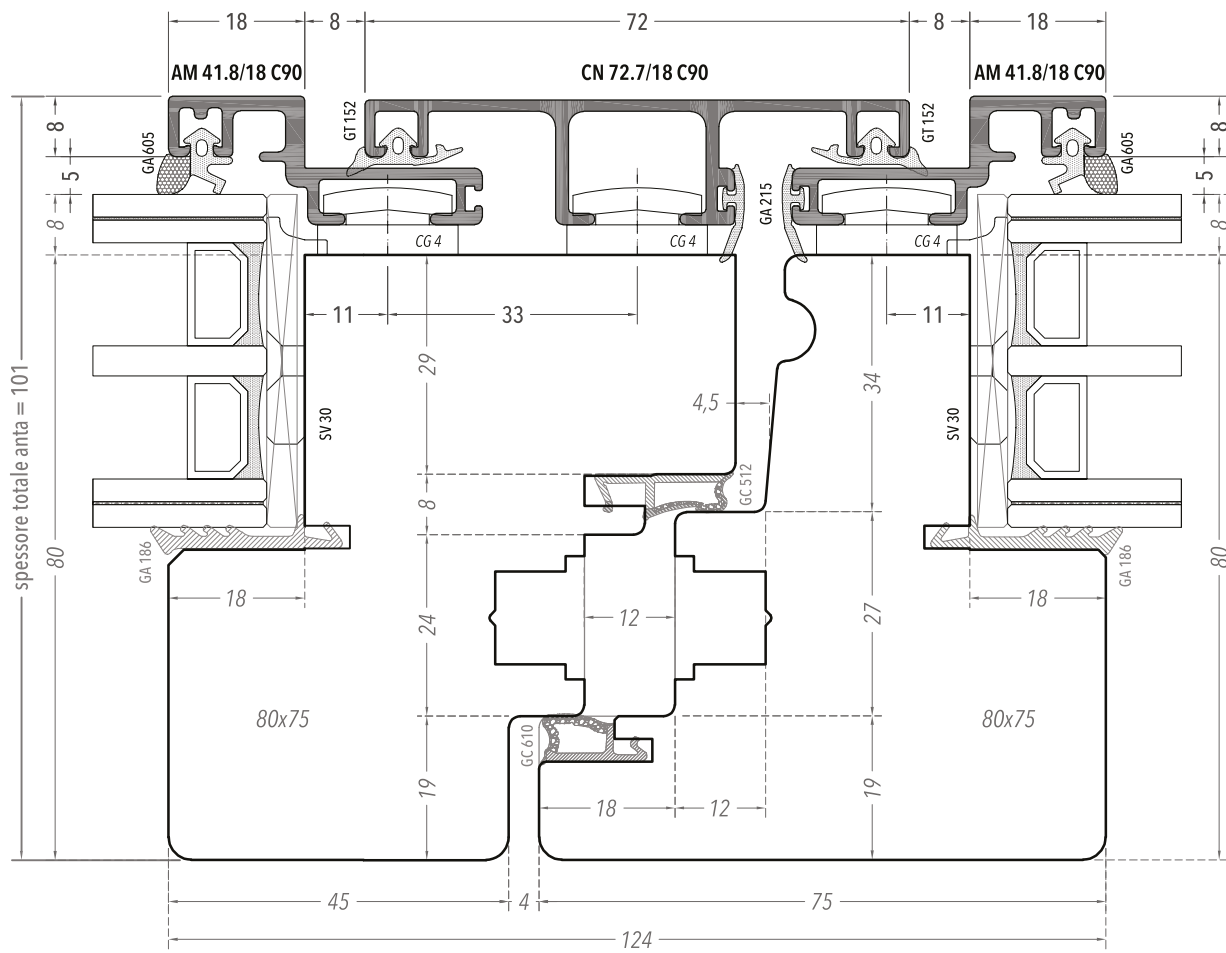



**PORTAFINESTRA**

SEZIONE VERTICALE  
NODO INFERIORE  
SCALA 1:1

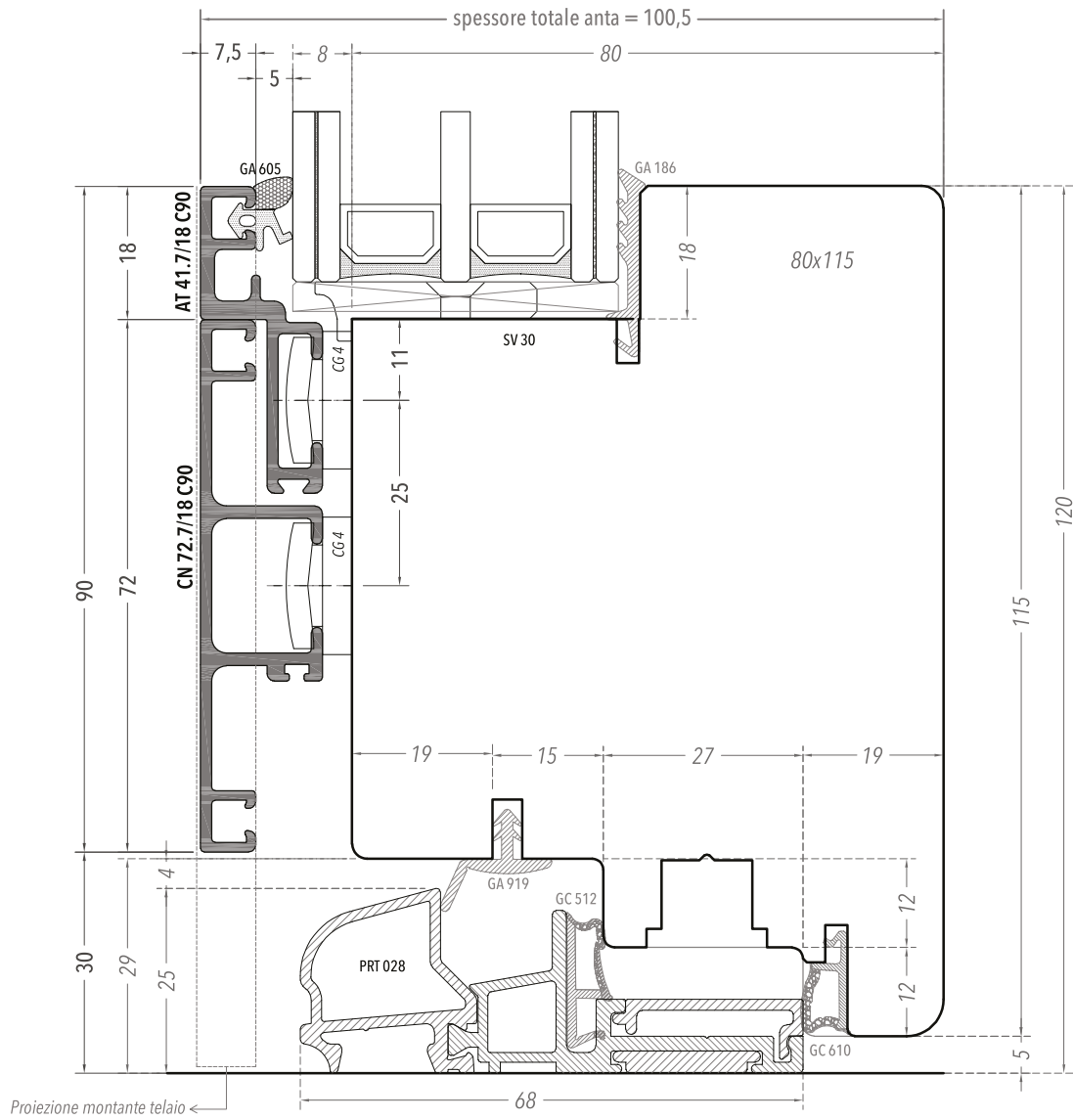
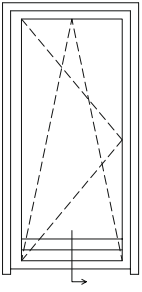



Spessore telaio 70  
Spessore anta 80

# Alumfast Orizon

---

SLIM HP80  
VETRO A FILO

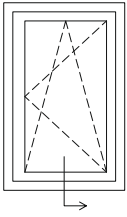

**FINESTRA**

SEZIONE VERTICALE  
NODO INFERIORE  
SCALA 1:1

Variante Slide  
con profilo  
inclinato a 15°

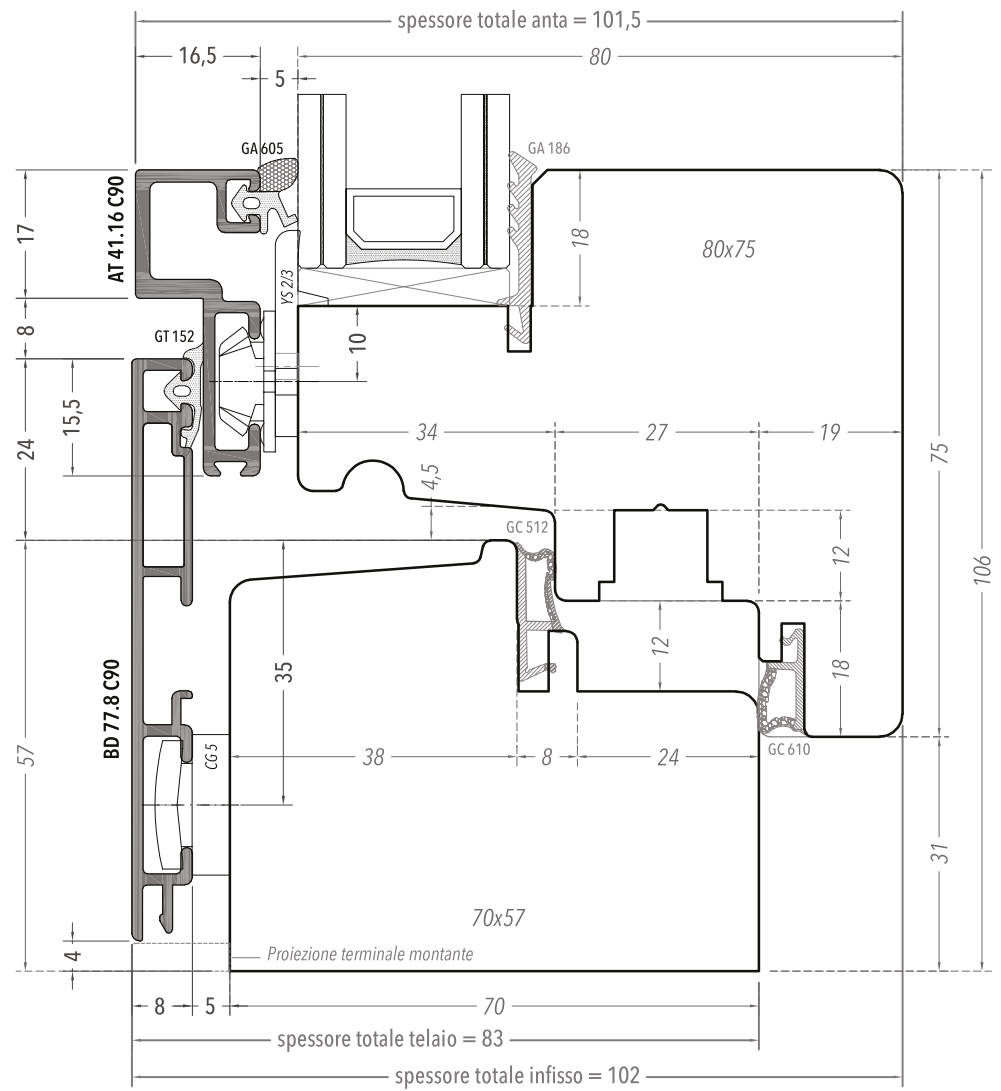
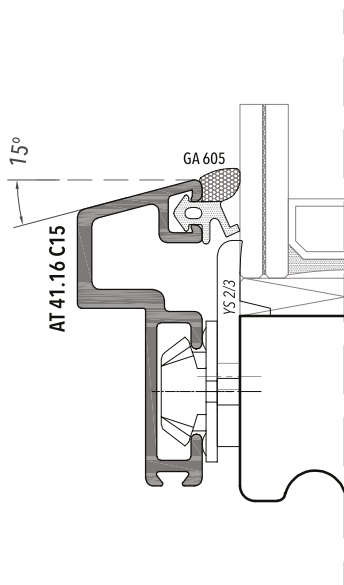

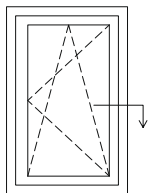

**FINESTRA**

SEZIONE ORIZZONTALE  
NODO LATERALE  
SCALA 1:1

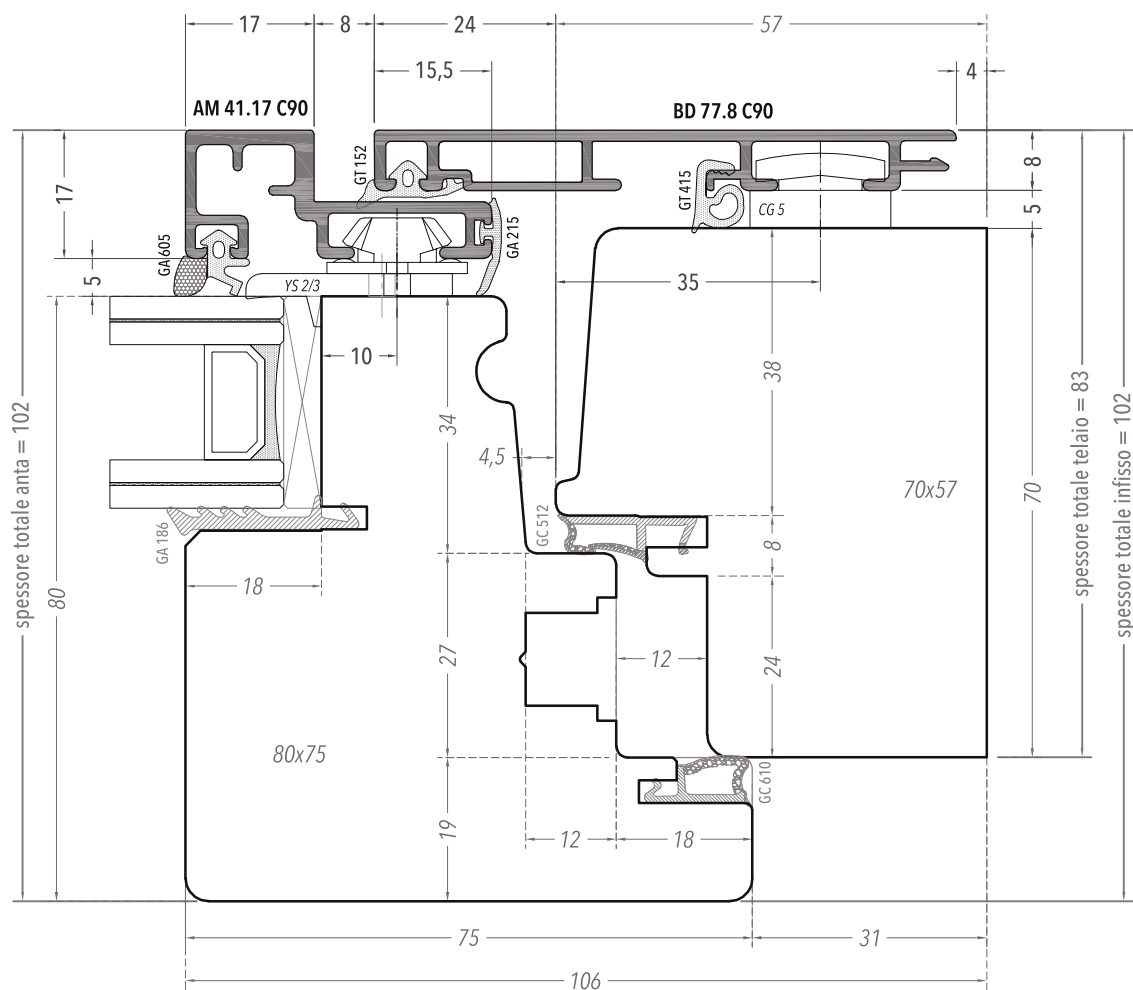
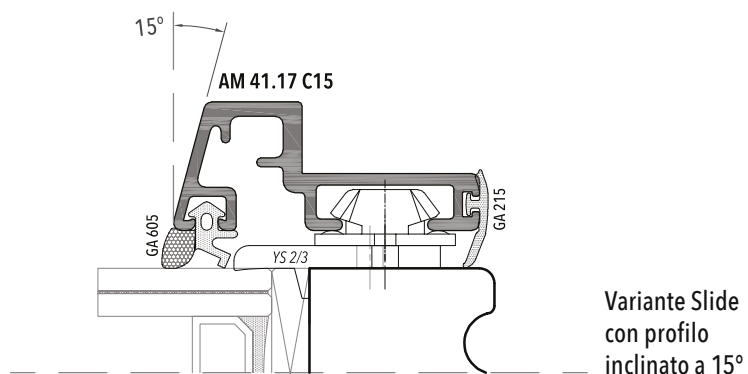

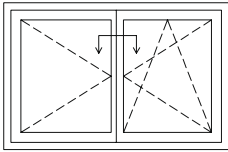

**FINESTRA**

SEZIONE ORIZZONTALE  
NODO CENTRALE  
SCALA 1:1

Variante Slide  
con profilo  
inclinato a 15°

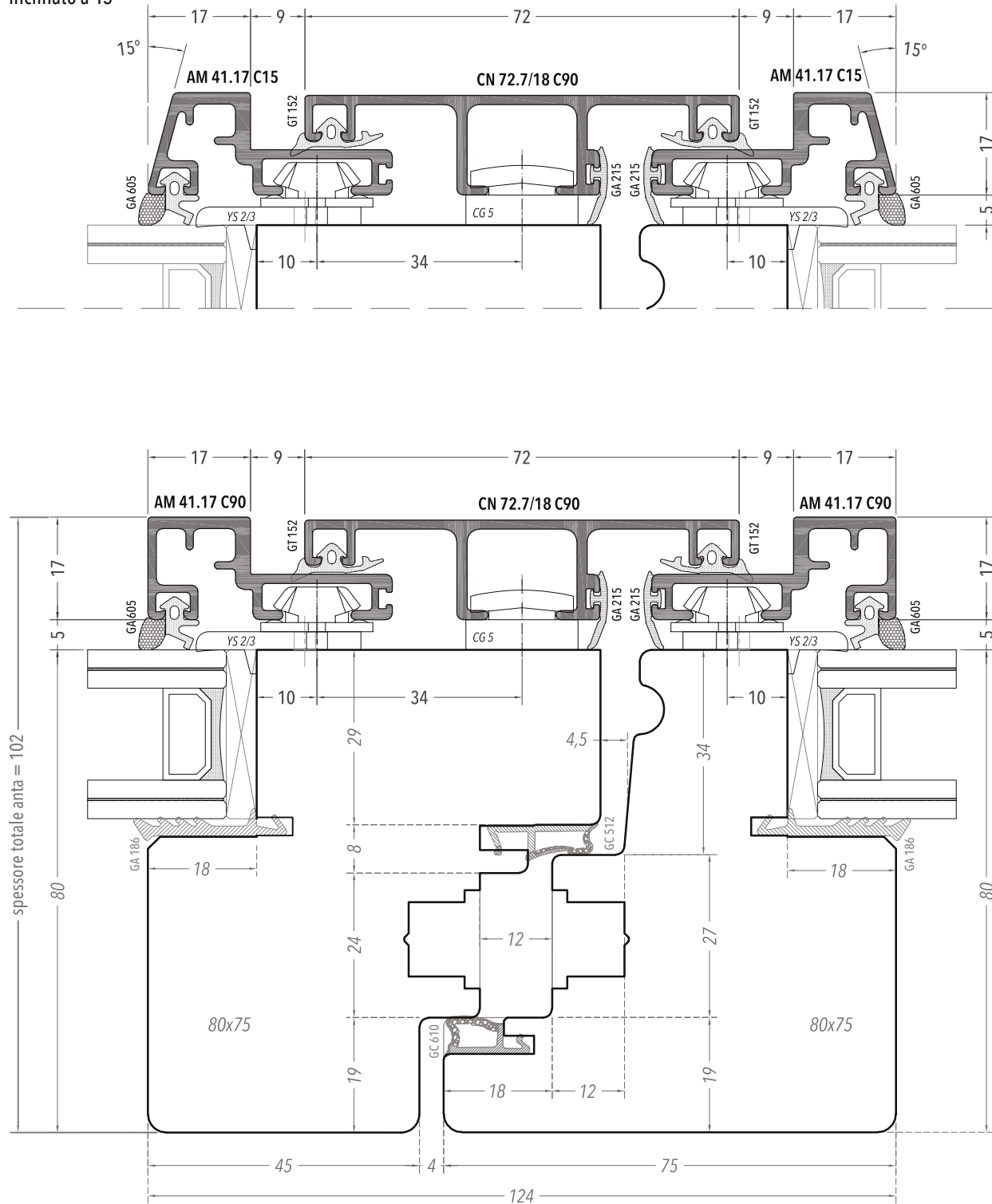

**PORTAFINESTRA**

SEZIONE VERTICALE  
NODO INFERIORE  
SCALA 1:1

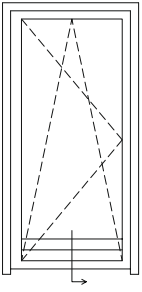

Variante Slide  
con profilo  
inclinato a 15°

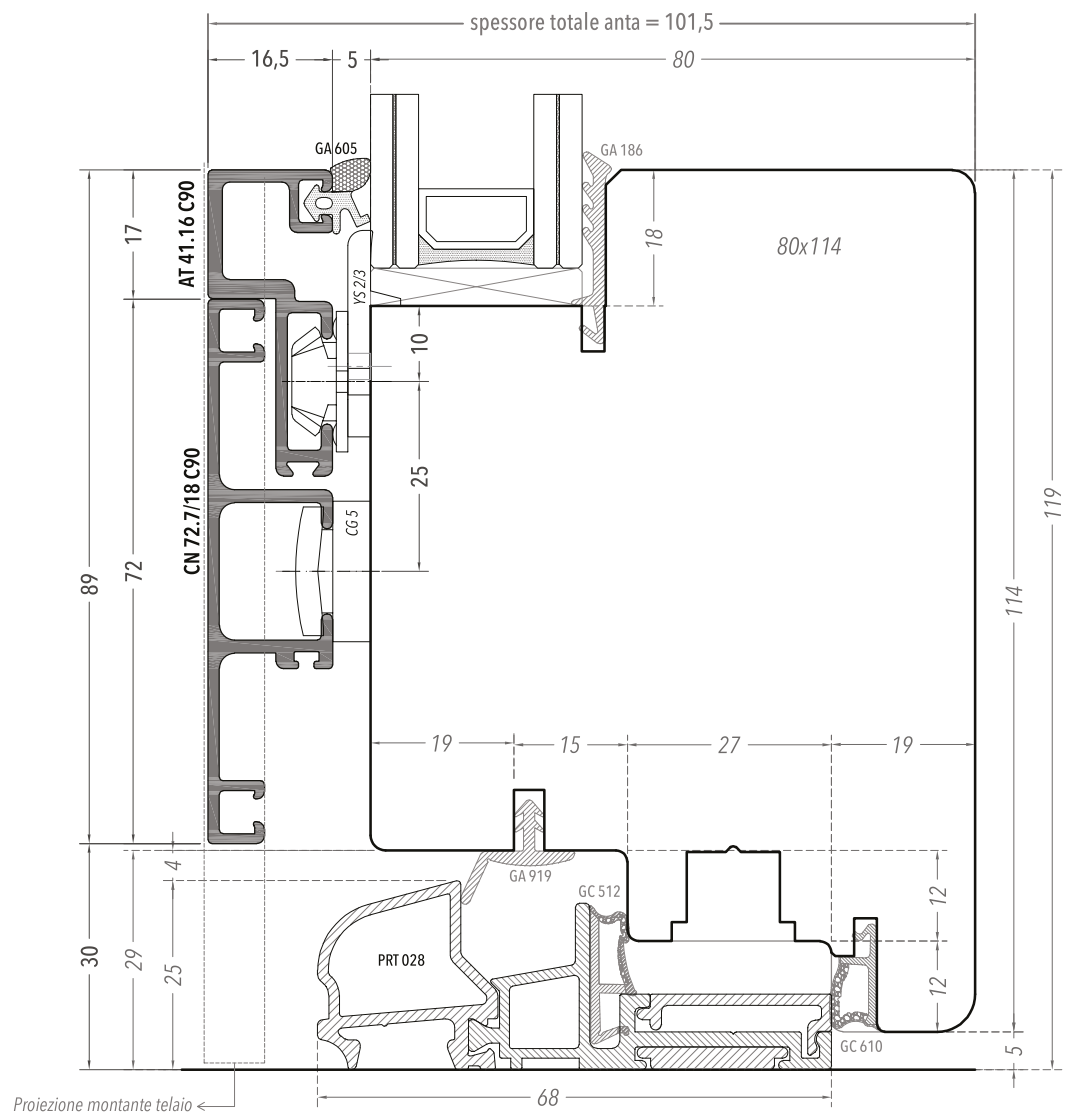
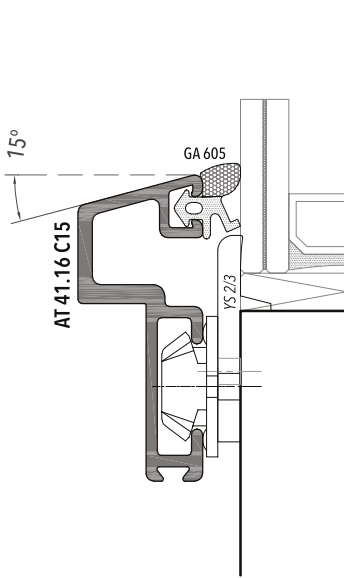



Spessore telaio 68  
Spessore anta 68



# Alumfast Orizon

---

SISTEMA 21

SISTEMA 16

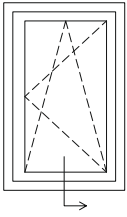

**FINESTRA**

SEZIONE VERTICALE  
NODO INFERIORE  
SCALA 1:1

Variante Slide  
con profilo  
inclinato a 15°  
e vetro a filo

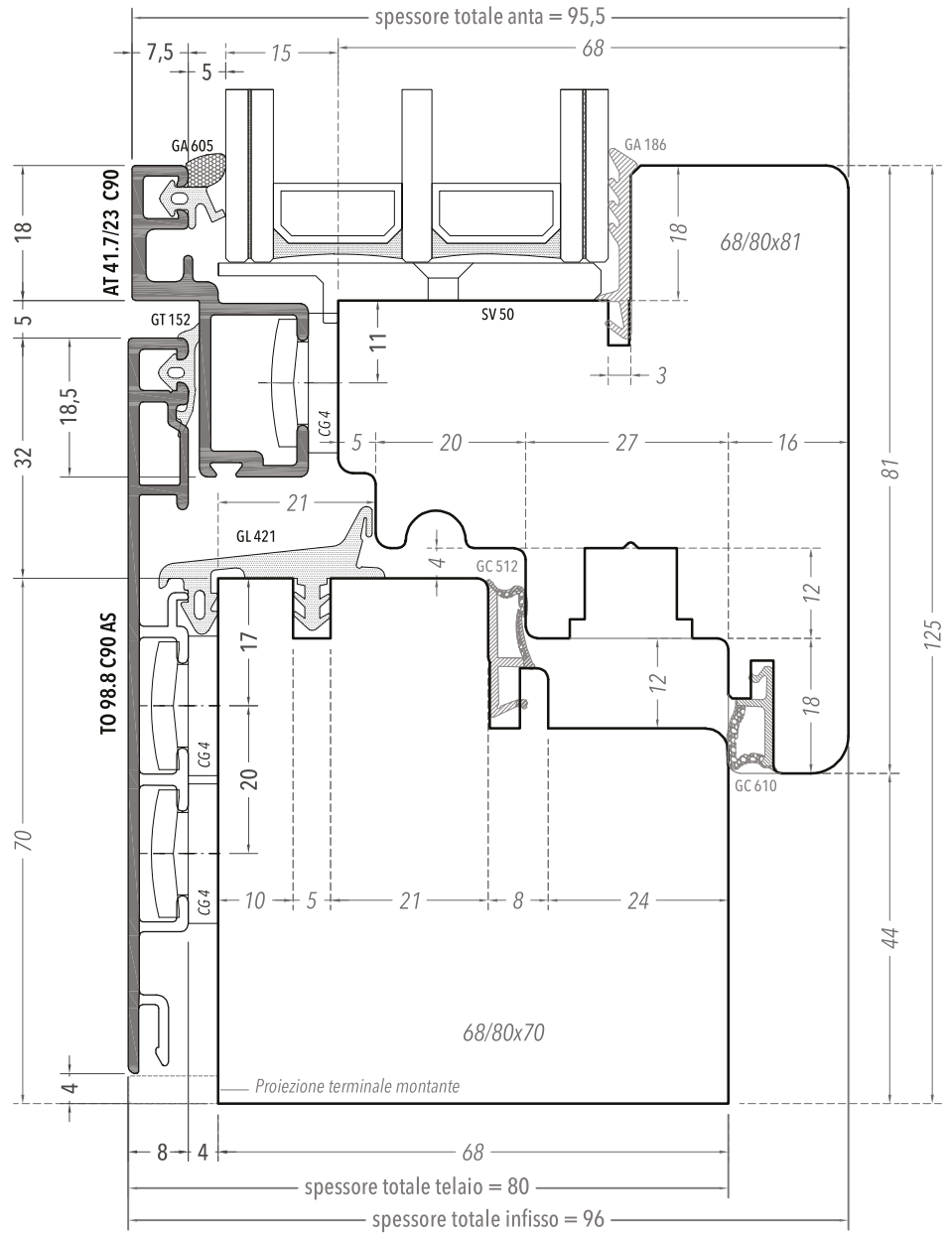
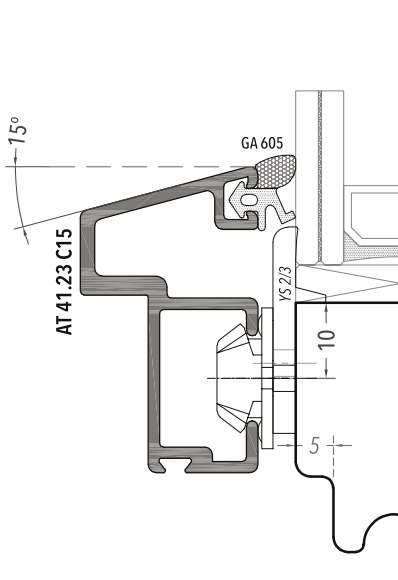

Soluzione valida anche per Sistema 16 con GL416.

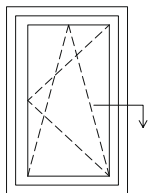

**FINESTRA**

SEZIONE ORIZZONTALE  
NODO LATERALE  
SCALA 1:1

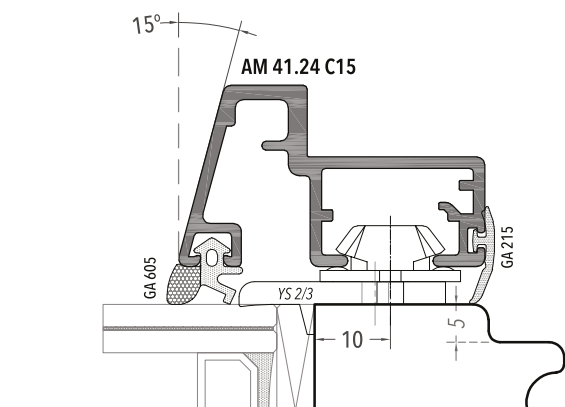

Variante Slide  
con profilo  
inclinato a 15°  
e vetro a filo

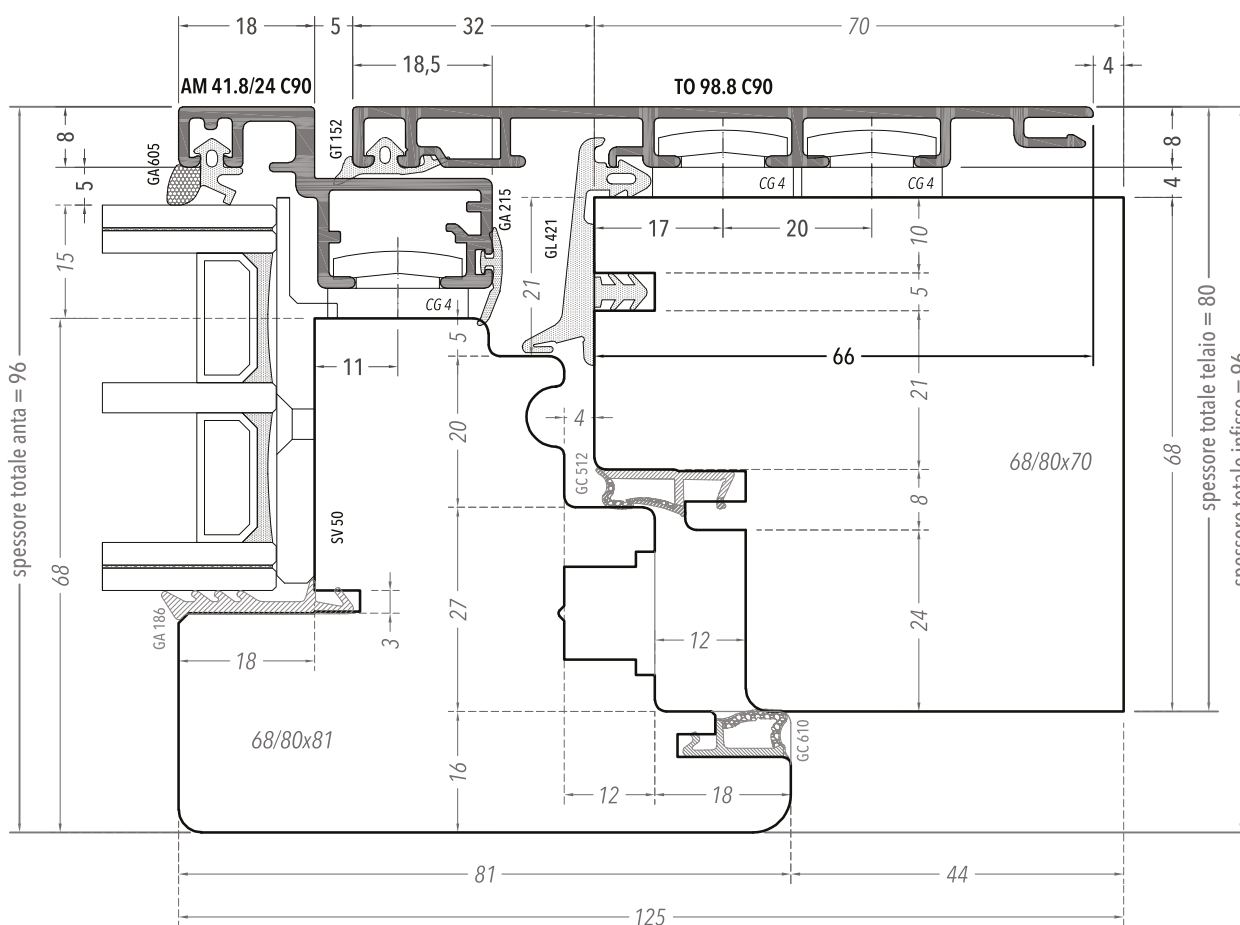

Soluzione valida anche per Sistema 16 con GL416.

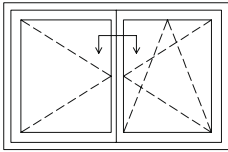

**FINESTRA**

SEZIONE ORIZZONTALE  
 NODO CENTRALE  
 SCALA 1:1

Variante Slide  
 con profilo  
 inclinato a 15°  
 e vetro a filo

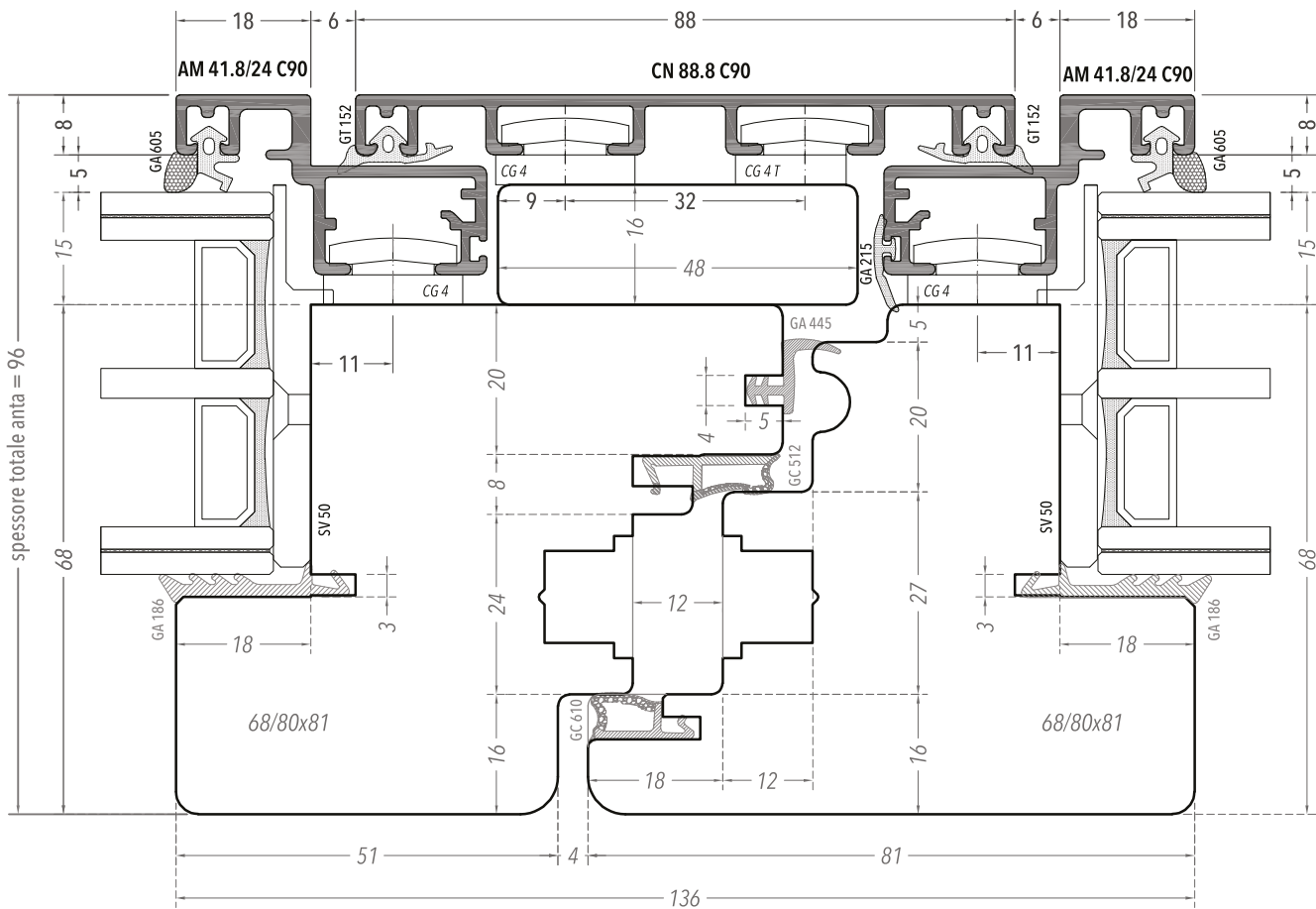
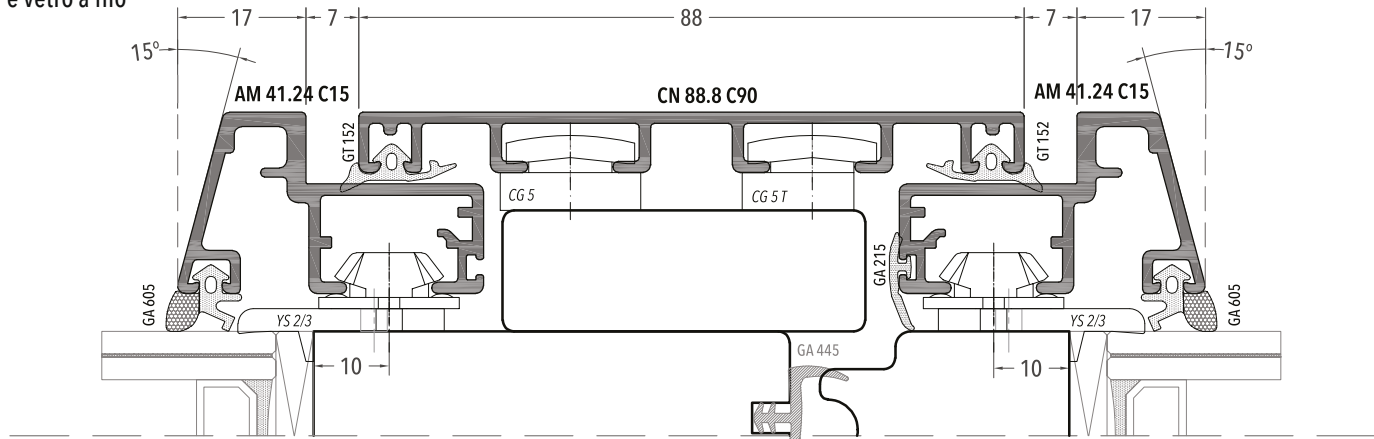

Soluzione valida anche per Sistema 16 con GL416.

**PORTAFINESTRA**

SEZIONE VERTICALE  
NODO INFERIORE  
SCALA 1:1

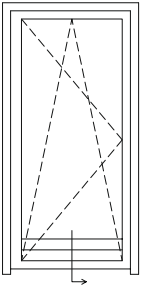

Variante Slide  
con profilo  
inclinato a 15°  
e vetro a filo

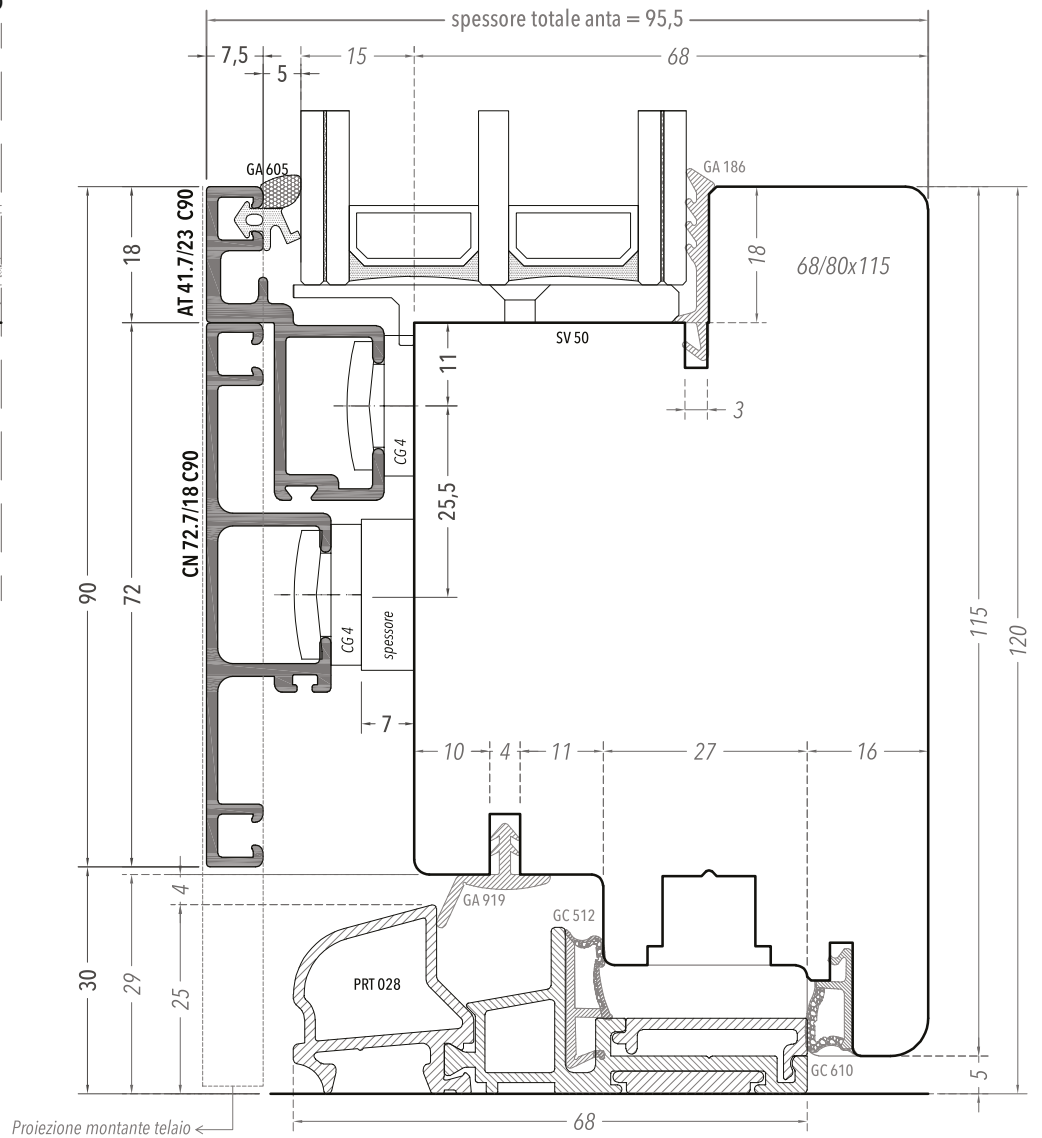
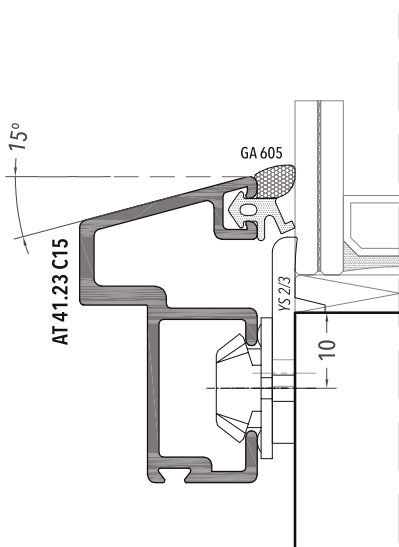

Soluzione valida anche per Sistema 16 con GL416.

**PORTAFINESTRA CON SERRATURA PASSANTE**

SEZIONE ORIZZONTALE  
NODO LATERALE  
SCALA 1:1

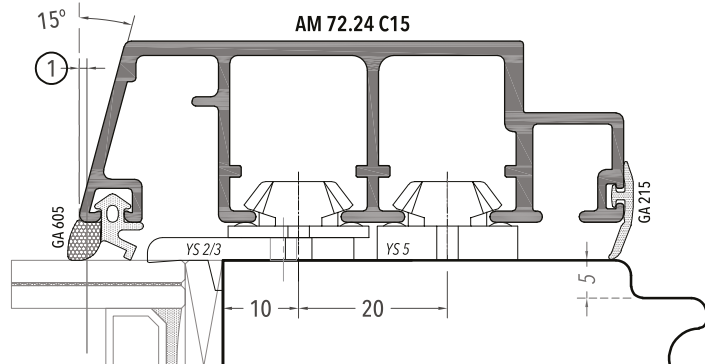
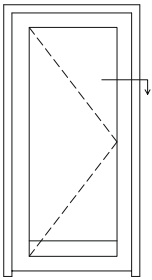

Variante Slide  
con profilo  
inclinato a 15°  
e vetro a filo

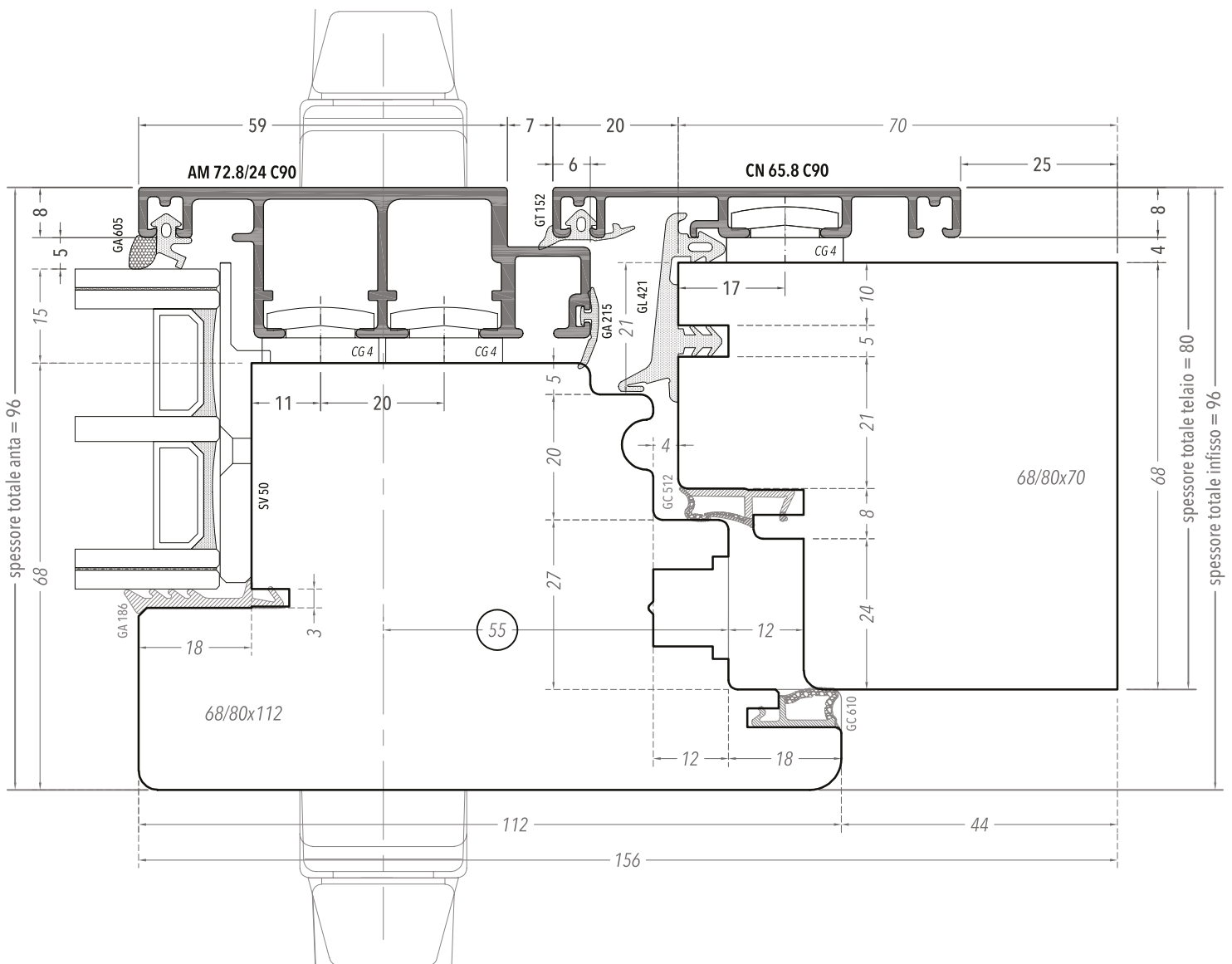

Soluzione valida anche per Sistema 16 con GL416. Entrata consigliata per la serratura: 55 mm.

**PORTAFINESTRA CON SERRATURA PASSANTE**

SEZIONE ORIZZONTALE  
NODO CENTRALE  
SCALA 1:1

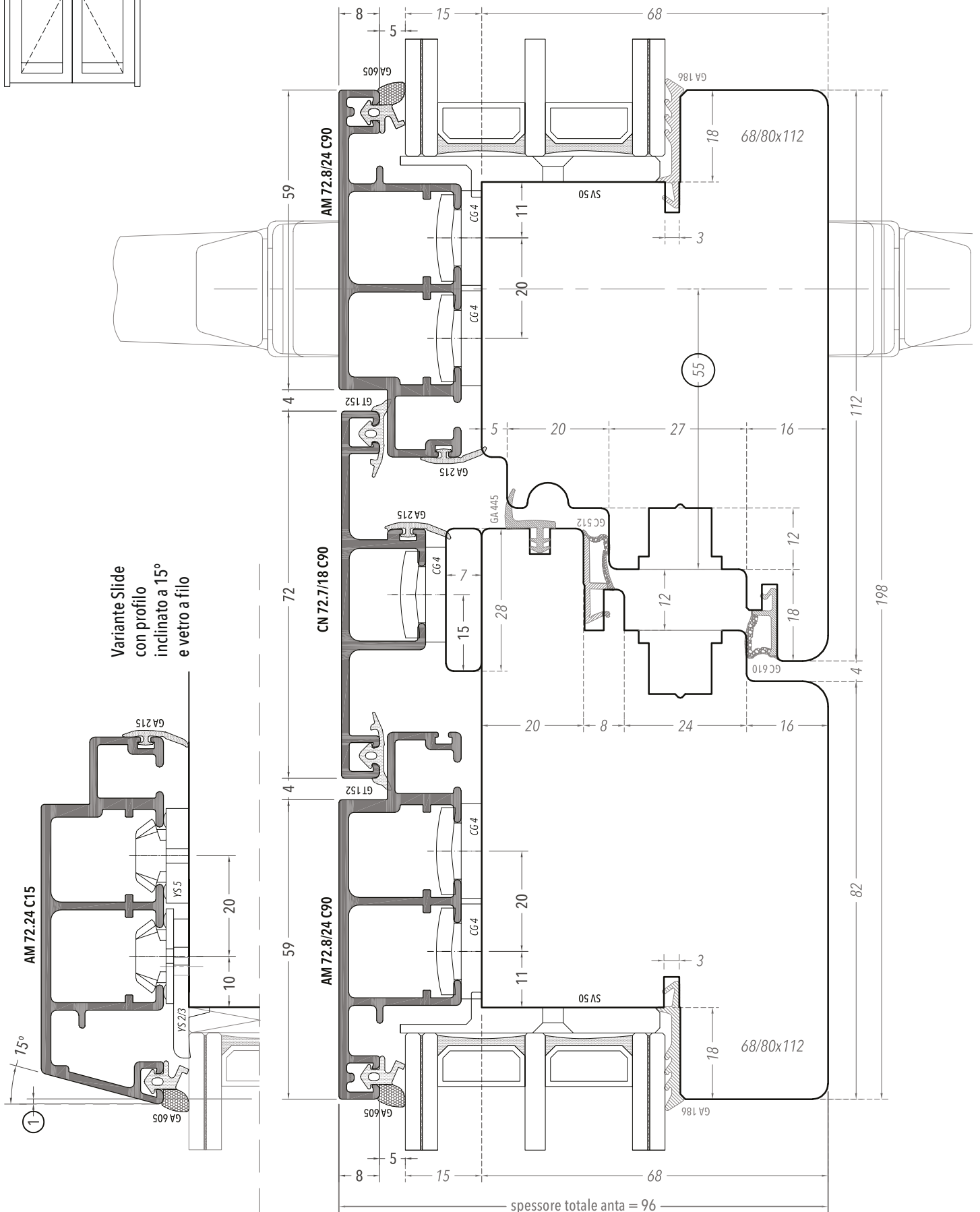
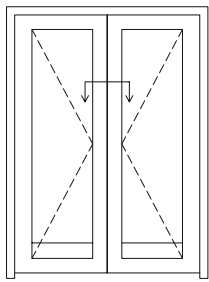

In caso di serratura passante, è possibile maggiorare solo il montante con la maniglia e lasciare invariata la sezione anta sugli altri lati. Entrata consigliata per la serratura: 55 mm. Soluzione valida anche per Sistema 16 con GL416.

**PORTAFINESTRA CON SERRATURA PASSANTE**

SEZIONE VERTICALE  
NODO INFERIORE  
SCALA 1:1

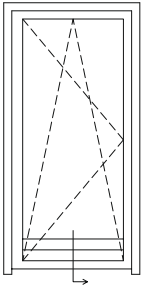

Variante Slide  
con profilo  
inclinato a 15°  
e vetro a filo

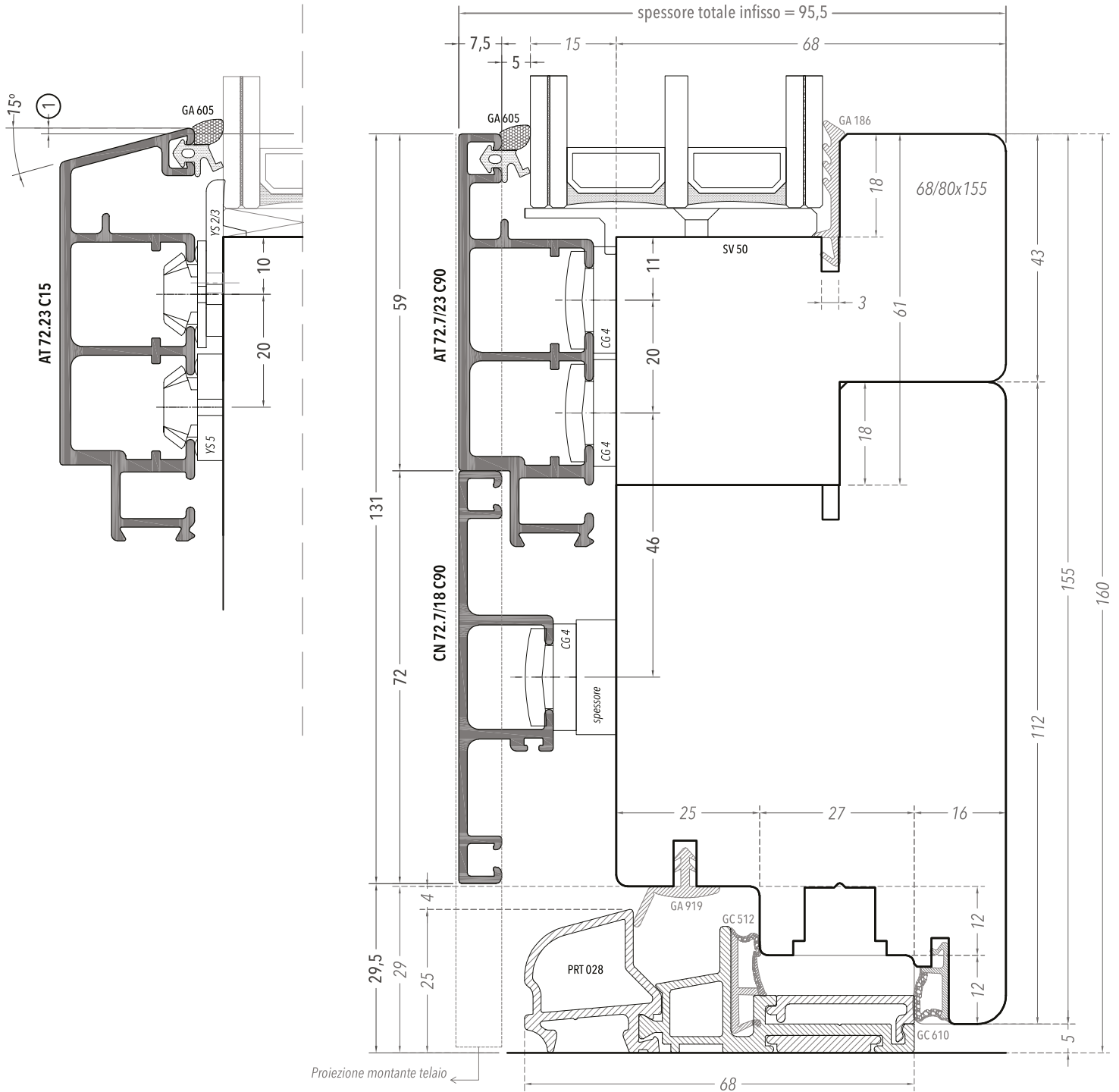

Soluzione valida anche per Sistema 16 con GL416.



**APRIBILE CON SOTTO-LUCE**

SEZIONE VERTICALE  
NODO ABBINAMENTO  
SCALA 1:1

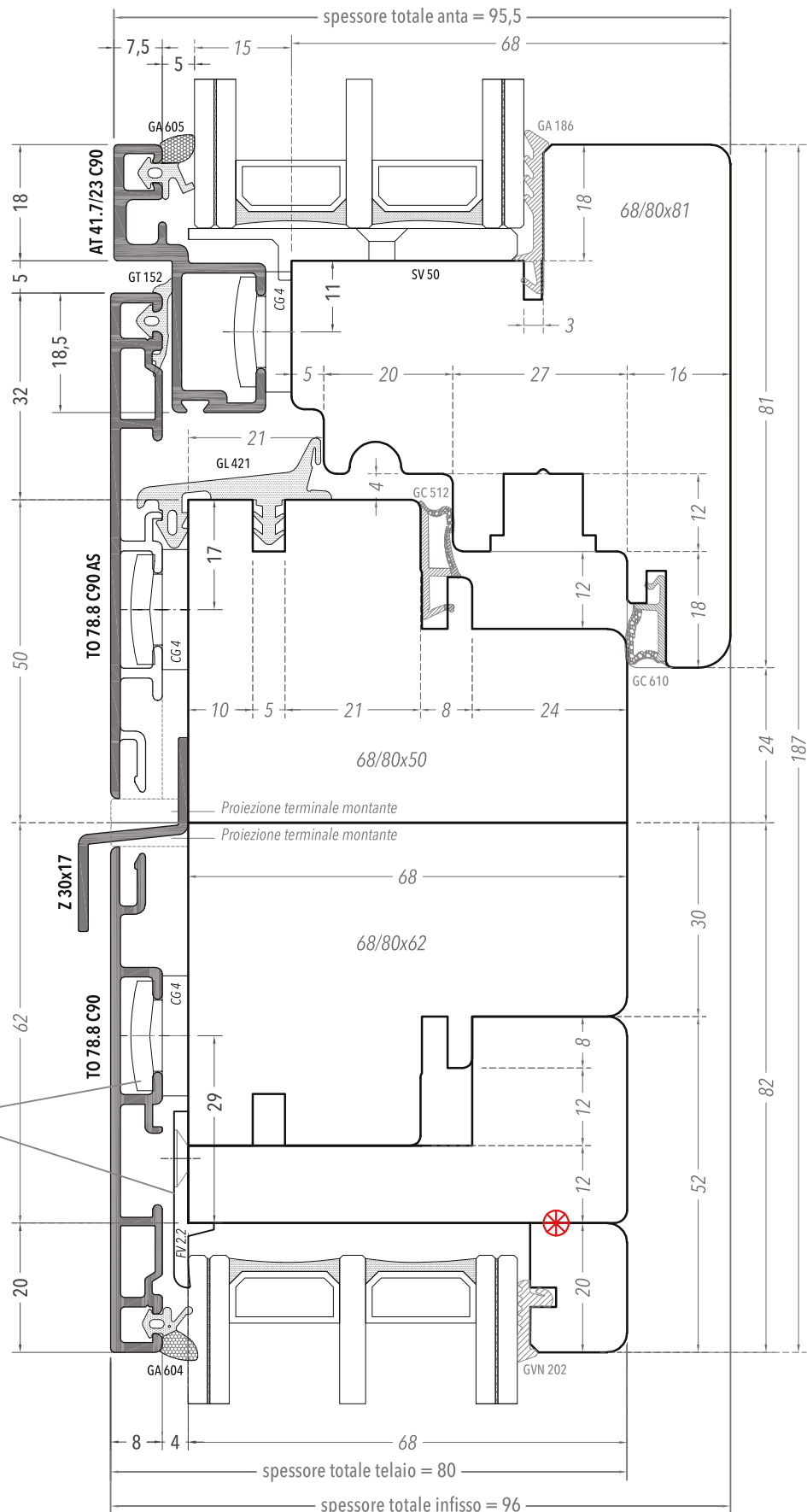
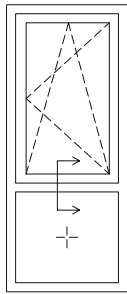

Alternare alla clip girevole una basetta fermavetro auto-posizionante FV 2.2

Siiconatura dei listelli in legno



Il profilo Z3x17 verrà fornito con una lunghezza pari all'esterno telaio. Dovrà essere tagliato a misura luce interna montanti telaio in alluminio. Soluzione consigliata per abbinamenti di grandi dimensioni.

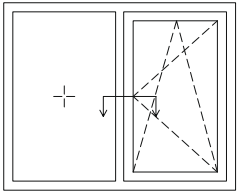

**FINESTRA CON FIANCO-LUCE**

SEZIONE ORIZZONTALE  
NODO ABBINAMENTO  
SCALA 1:1

Alternare alla clip girevole una basetta fermavetro auto-posizionante FV 2.2

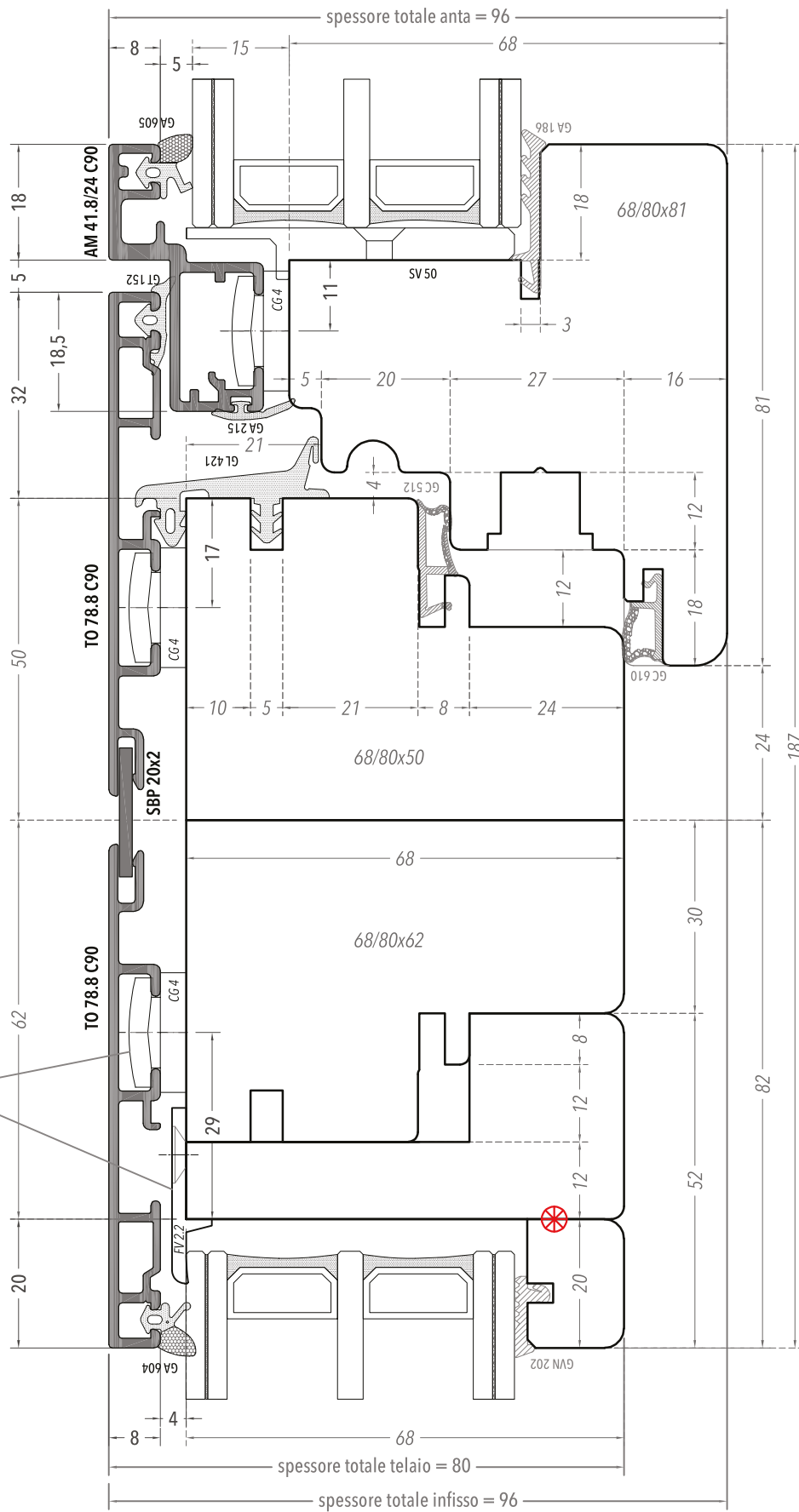

 Siliconatura dei listelli in legno

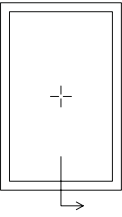

**FISSO**

SEZIONE VERTICALE  
NODO INFERIORE  
SCALA 1:1

 Siliconatura dei listelli in legno

Alternare alla clip  
girevole una basetta  
fermavetro  
auto-posizionante FV 2.2

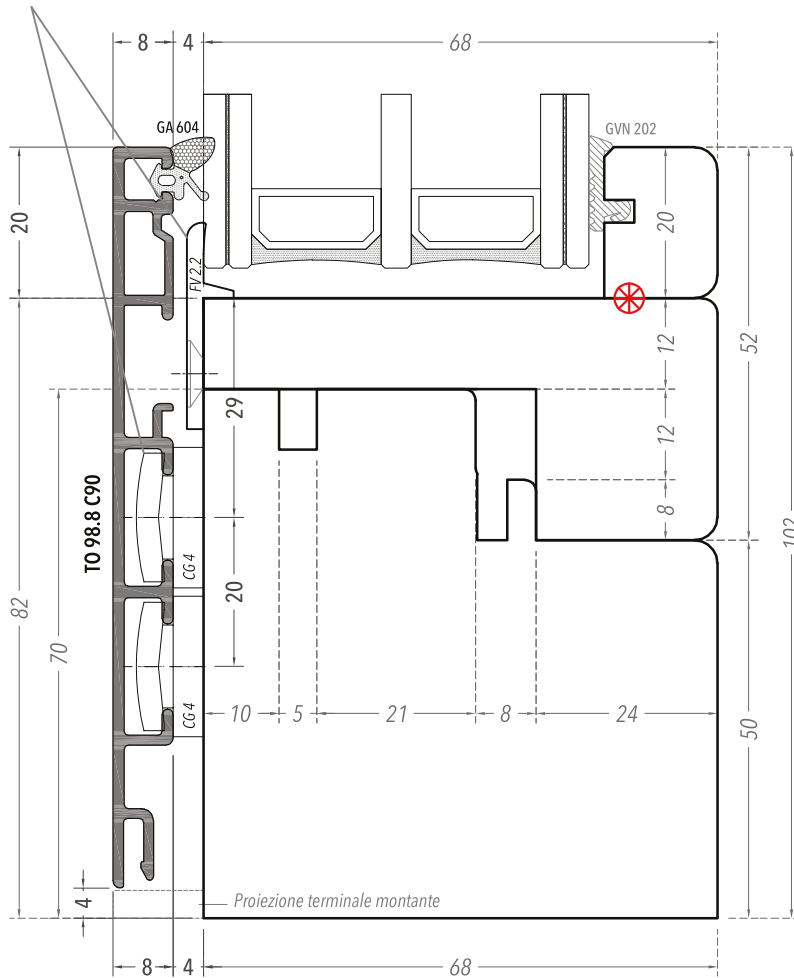

Variante fissaggio  
fermavetro con PVF

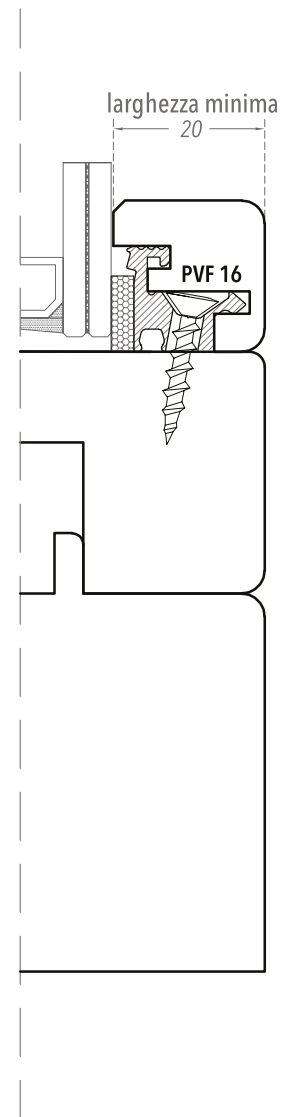

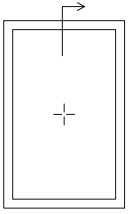

**FISSO**

SEZIONE VERTICALE  
NODO SUPERIORE  
SCALA 1:1

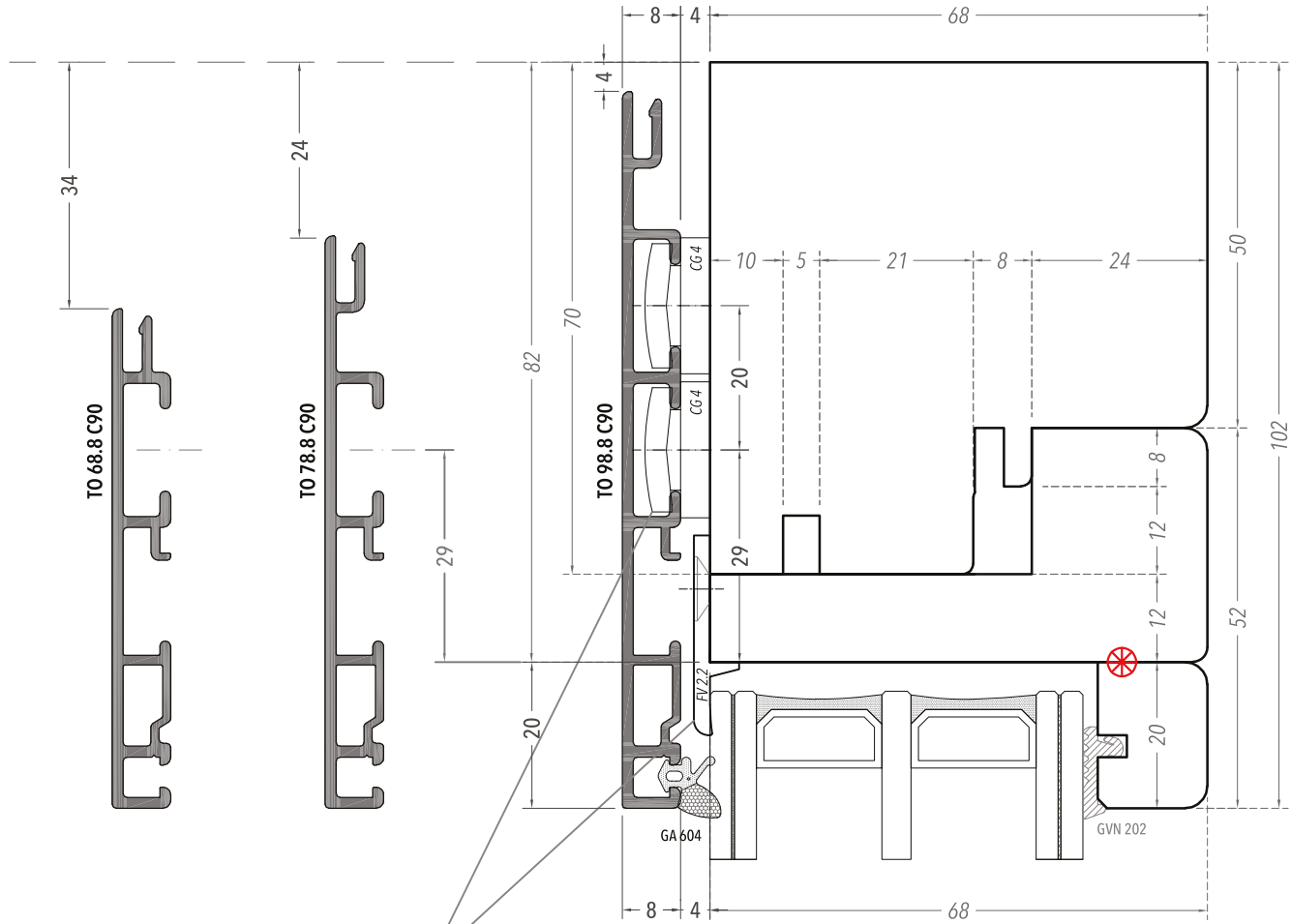

Alternare alla clip girevole una basetta  
fermavetro auto-posizionante FV 2.2

● Siliconatura dei listelli in legno

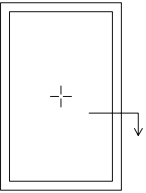

**FISSO**

SEZIONE ORIZZONTALE  
NODO LATERALE  
SCALA 1:1

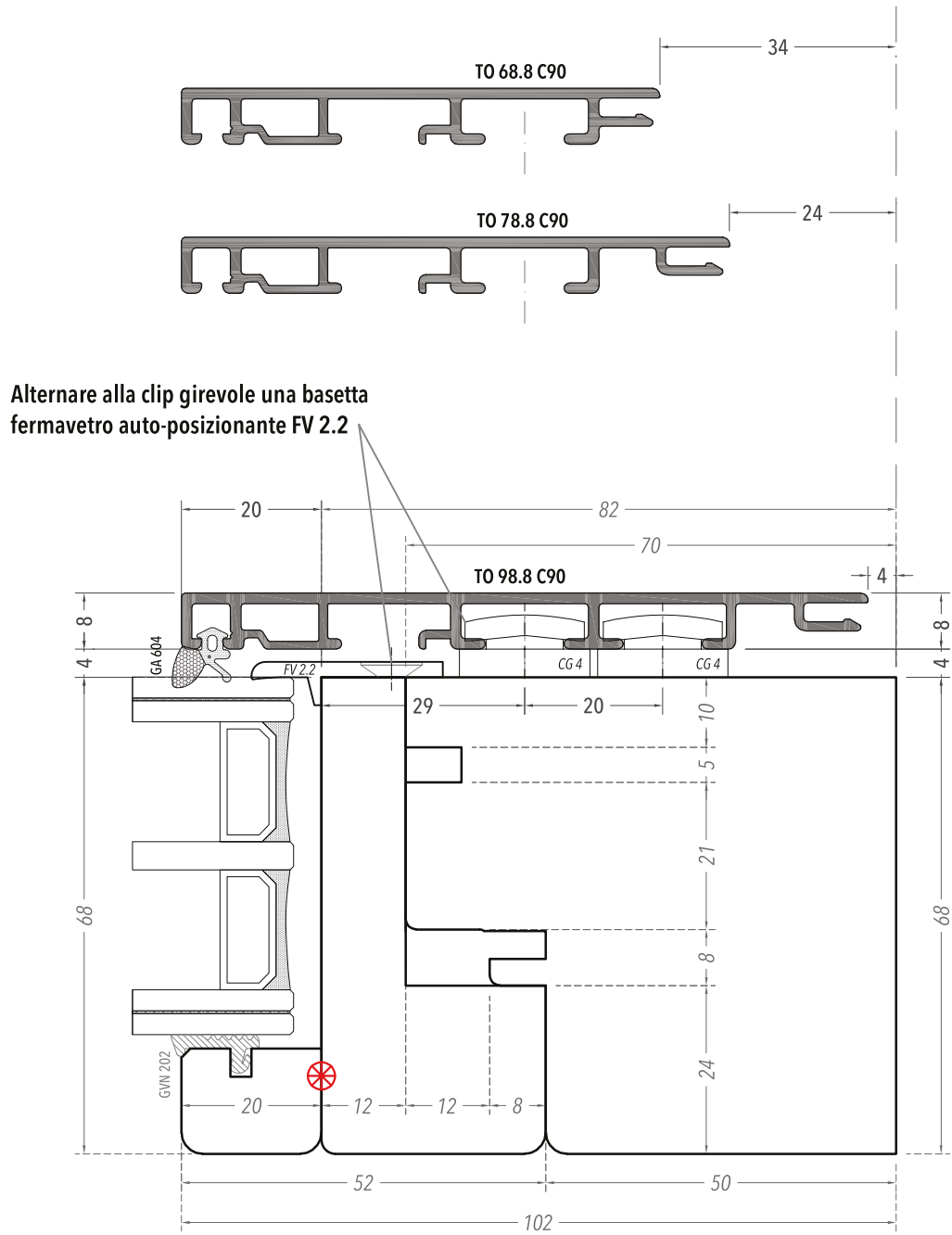

 Siliconatura dei listelli in legno



Spessore telaio 65  
Spessore anta 68

# Alumfast Orizon

---

SISTEMA 16 ECO

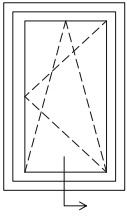

**FINESTRA**

SEZIONE VERTICALE  
NODO INFERIORE  
SCALA 1:1

Variante Slide  
con profilo  
inclinato a 15°  
e vetro a filo

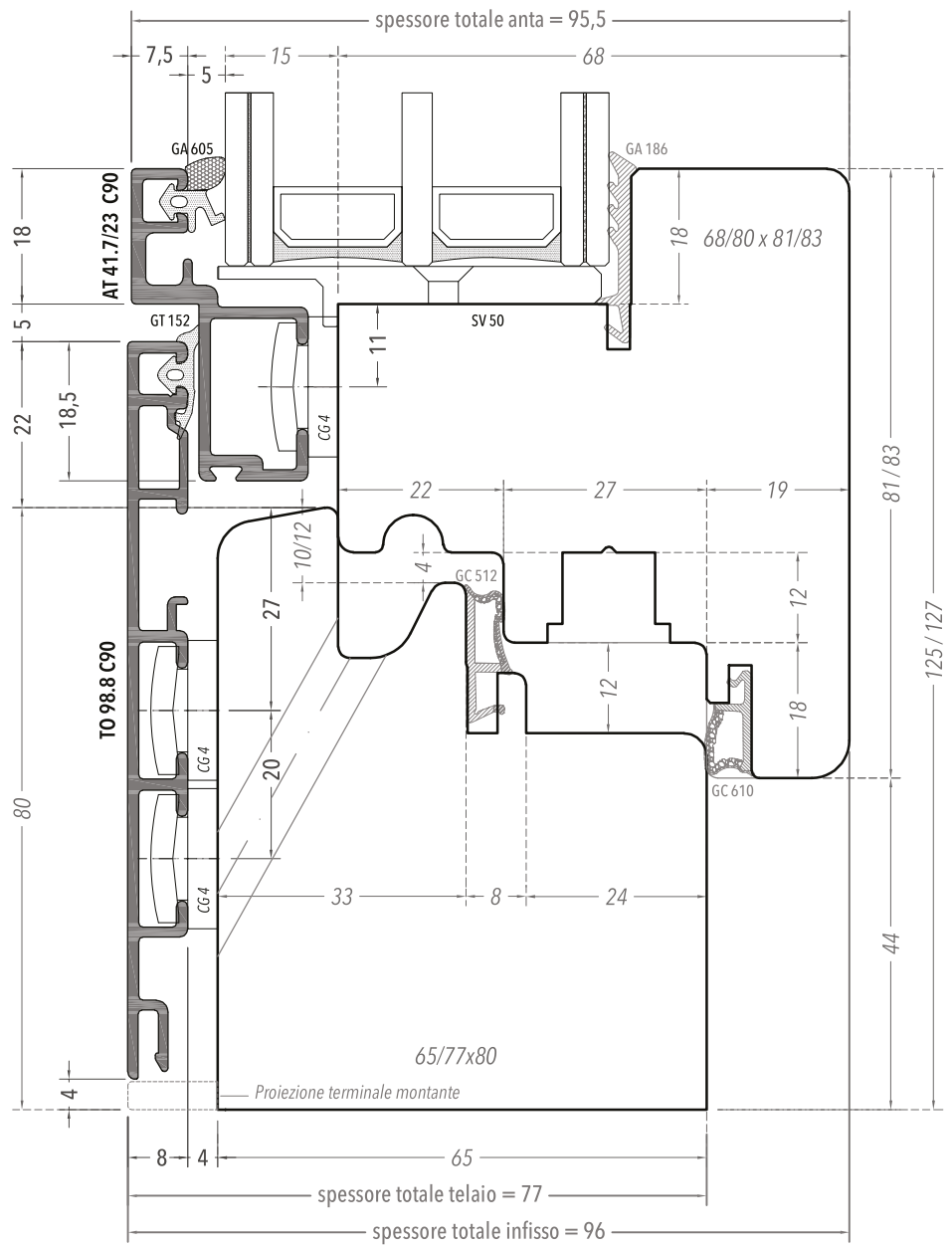
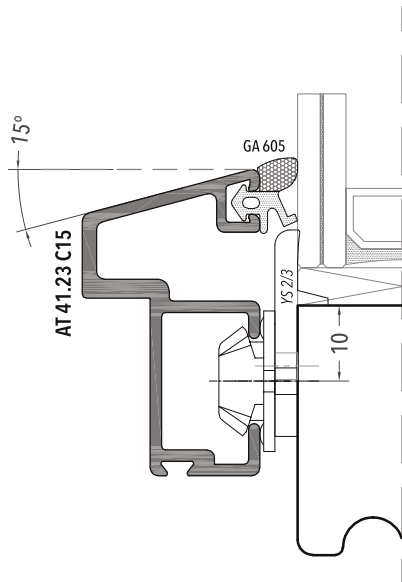



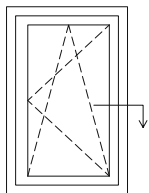

**FINESTRA**

SEZIONE ORIZZONTALE  
 NODO LATERALE  
 SCALA 1:1

Variante Slide  
 con profilo  
 inclinato a 15°  
 e vetro a filo

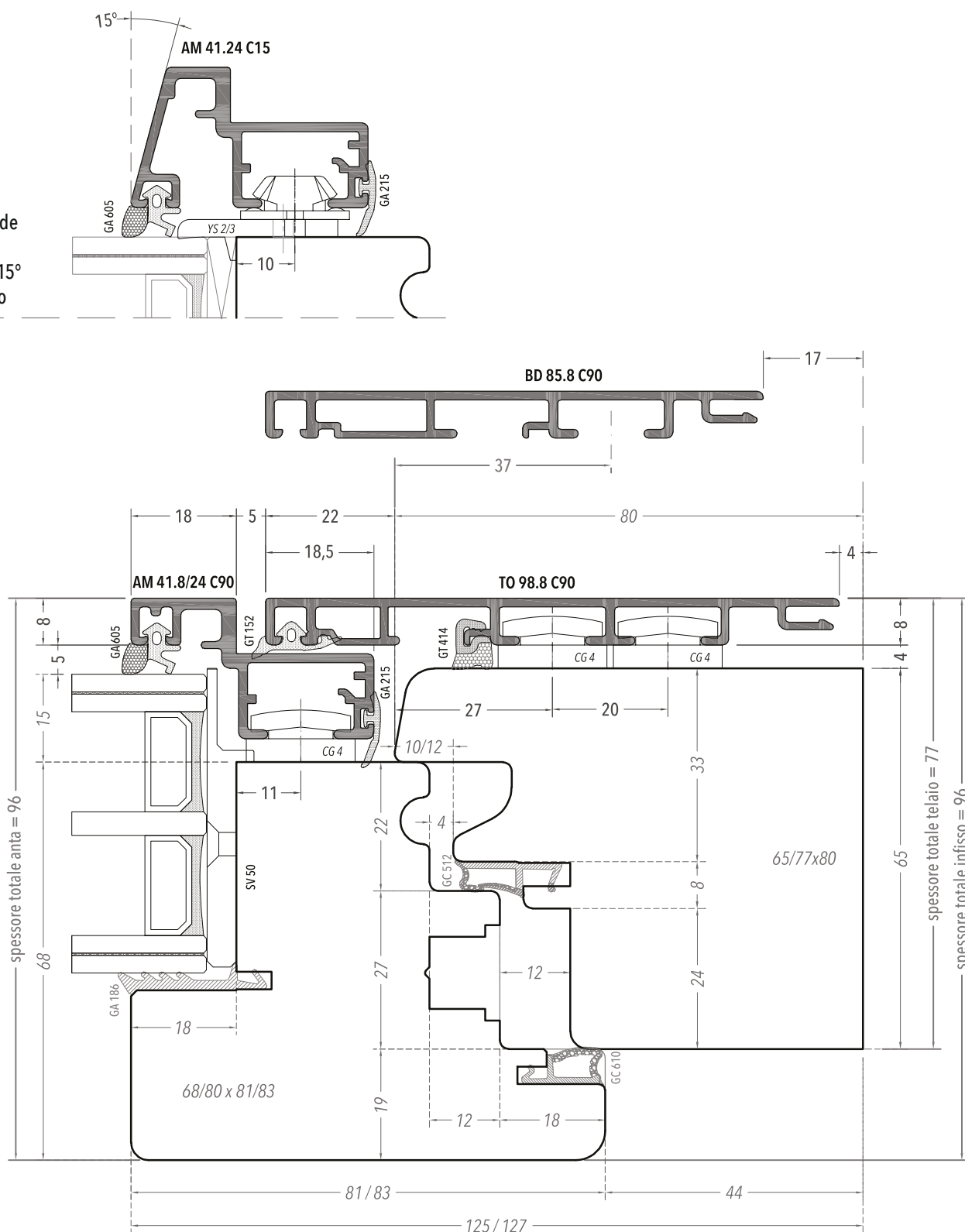

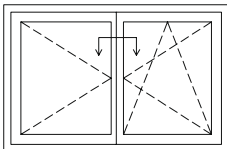

**FINESTRA**

SEZIONE ORIZZONTALE  
 NODO CENTRALE  
 SCALA 1:1

Variante Slide  
 con profilo  
 inclinato a 15°  
 e vetro a filo

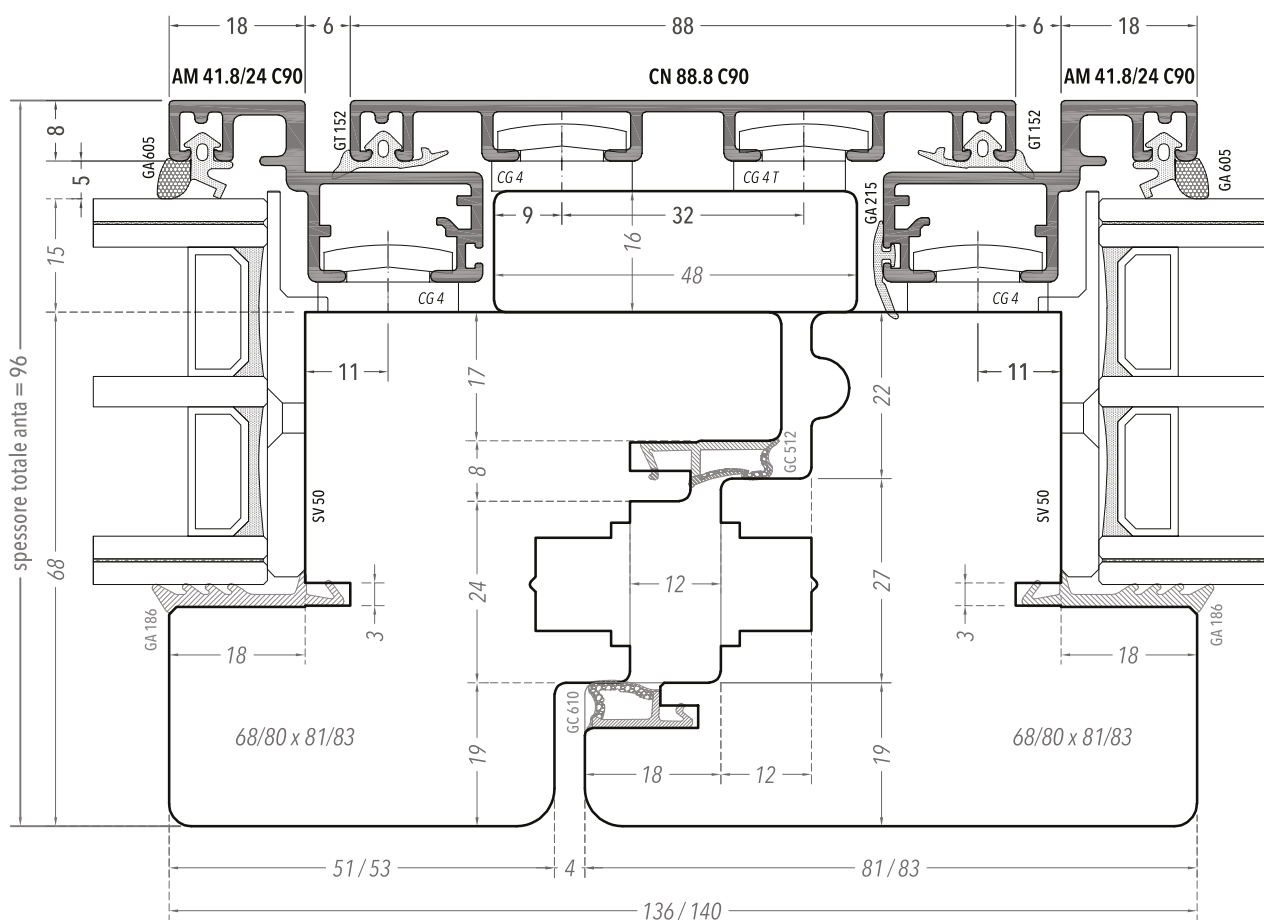
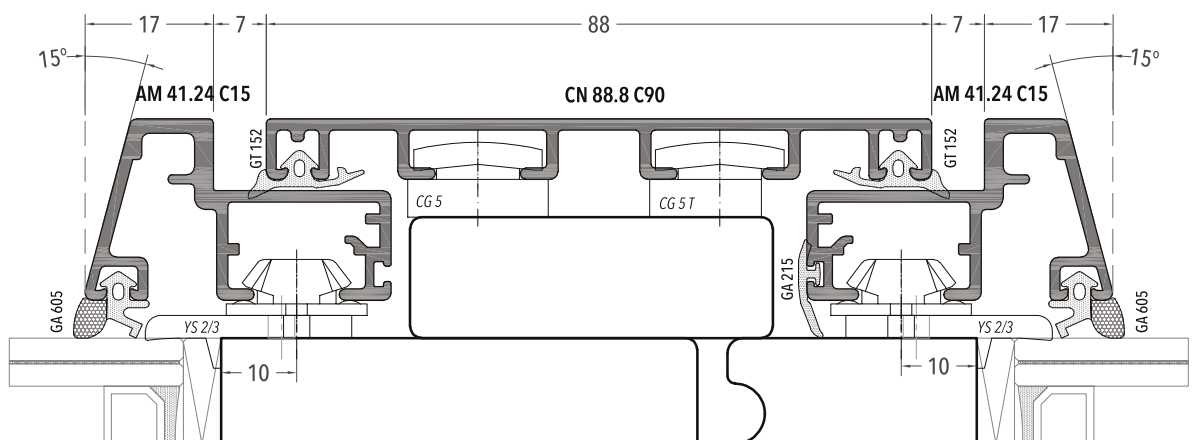

**PORTAFINESTRA**

SEZIONE VERTICALE  
NODO INFERIORE  
SCALA 1:1

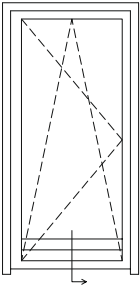

Variante Slide  
con profilo  
inclinato a 15°  
e vetro a filo

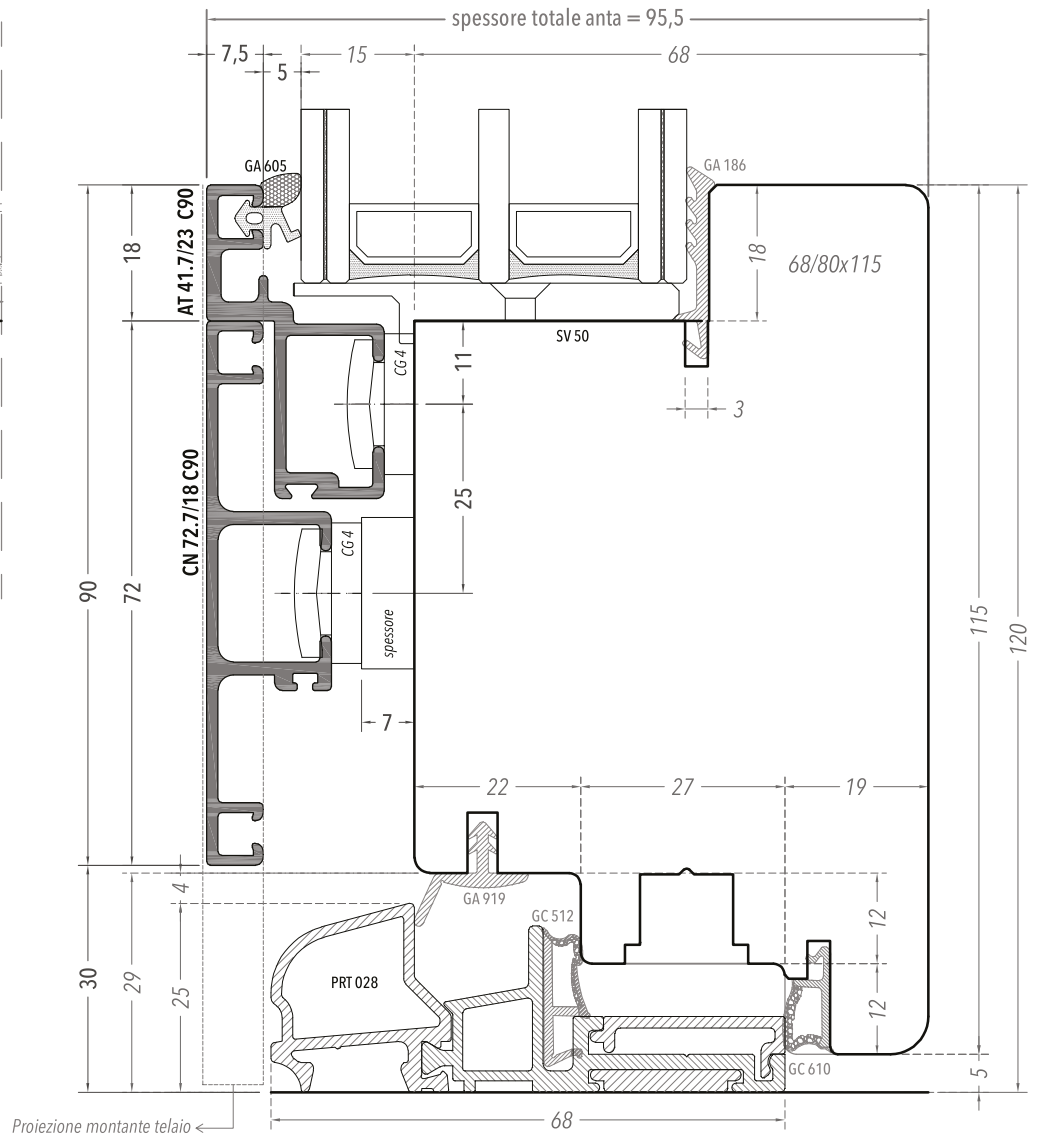
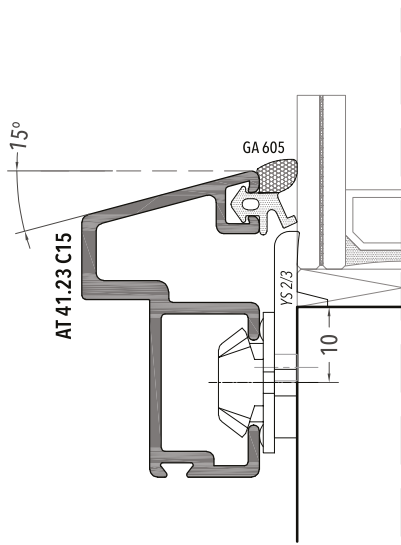



Spessore telaio 58  
Spessore anta 68  
Per serramenti legno Easy

# Bridge Easy

---

SLIM

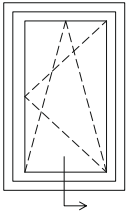

**FINESTRA**

SEZIONE VERTICALE  
 NODO INFERIORE  
 SCALA 1:1

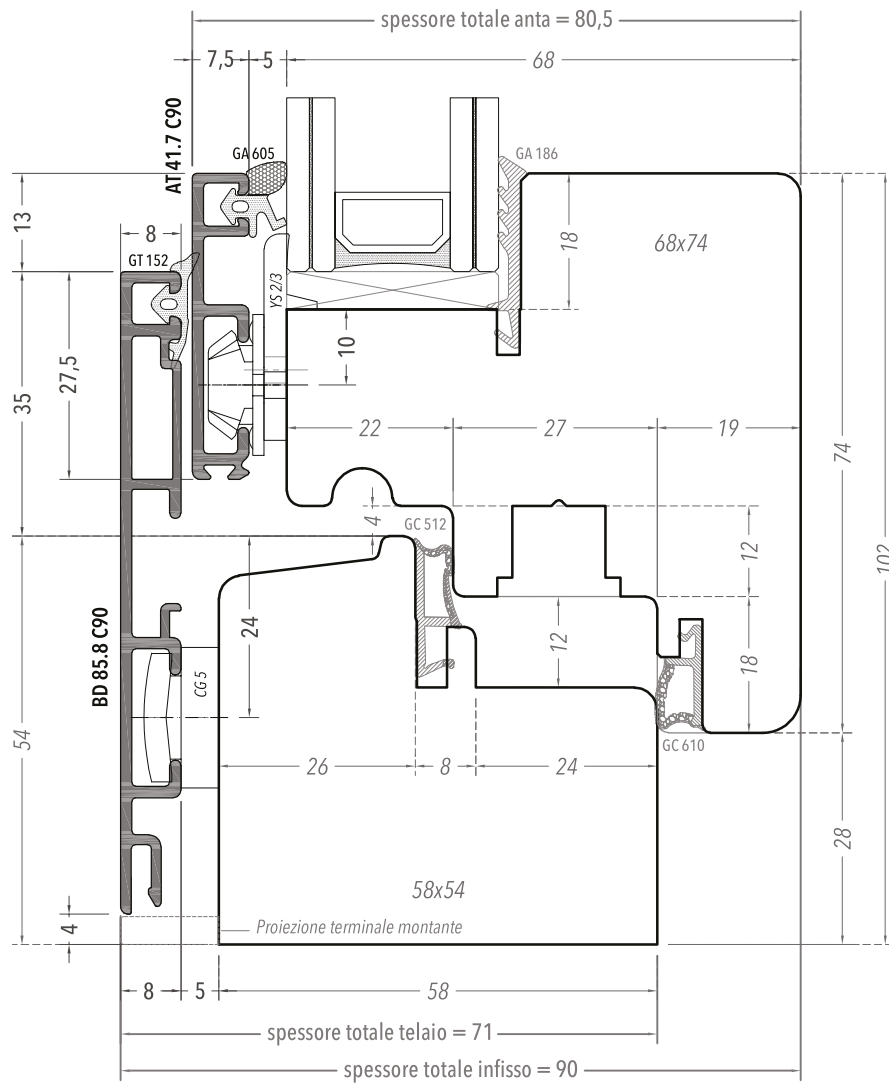

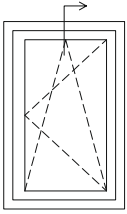

**FINESTRA**

SEZIONE VERTICALE  
 NODO SUPERIORE  
 SCALA 1:1

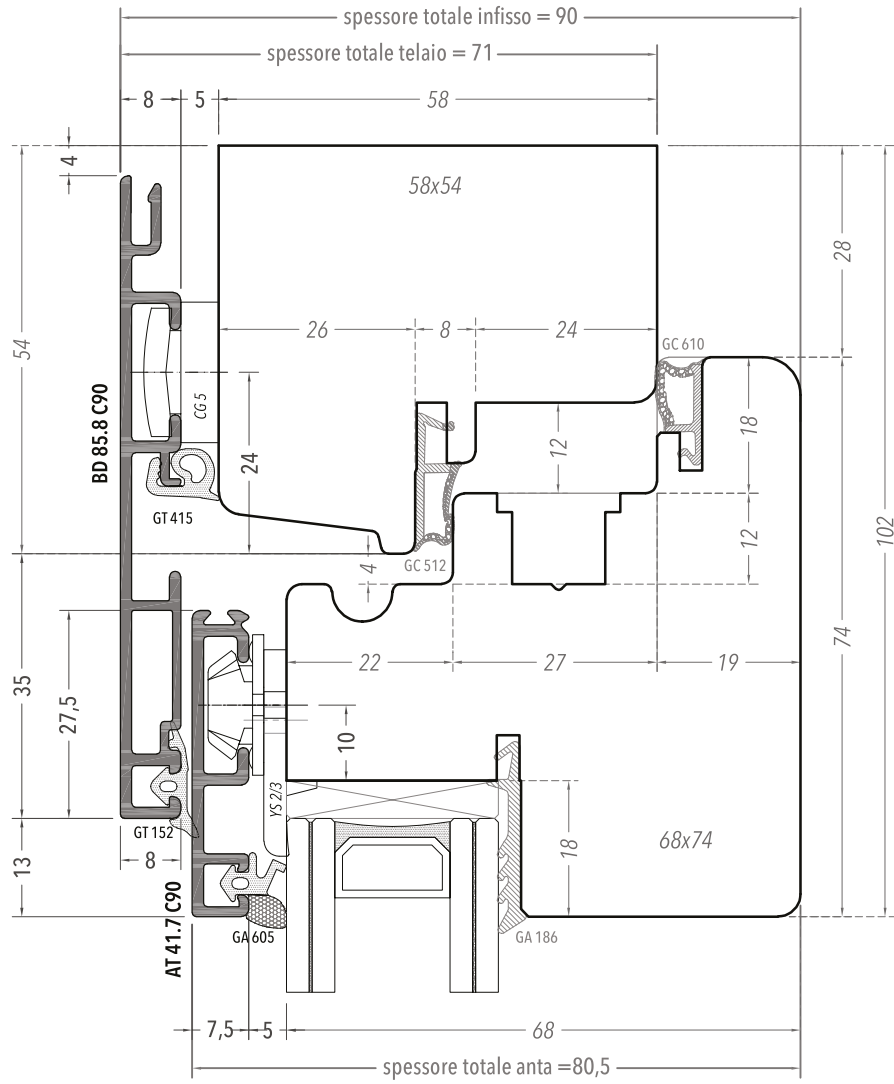

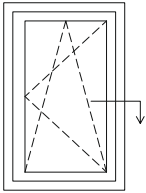

**FINESTRA**

SEZIONE ORIZZONTALE  
 NODO LATERALE  
 SCALA 1:1

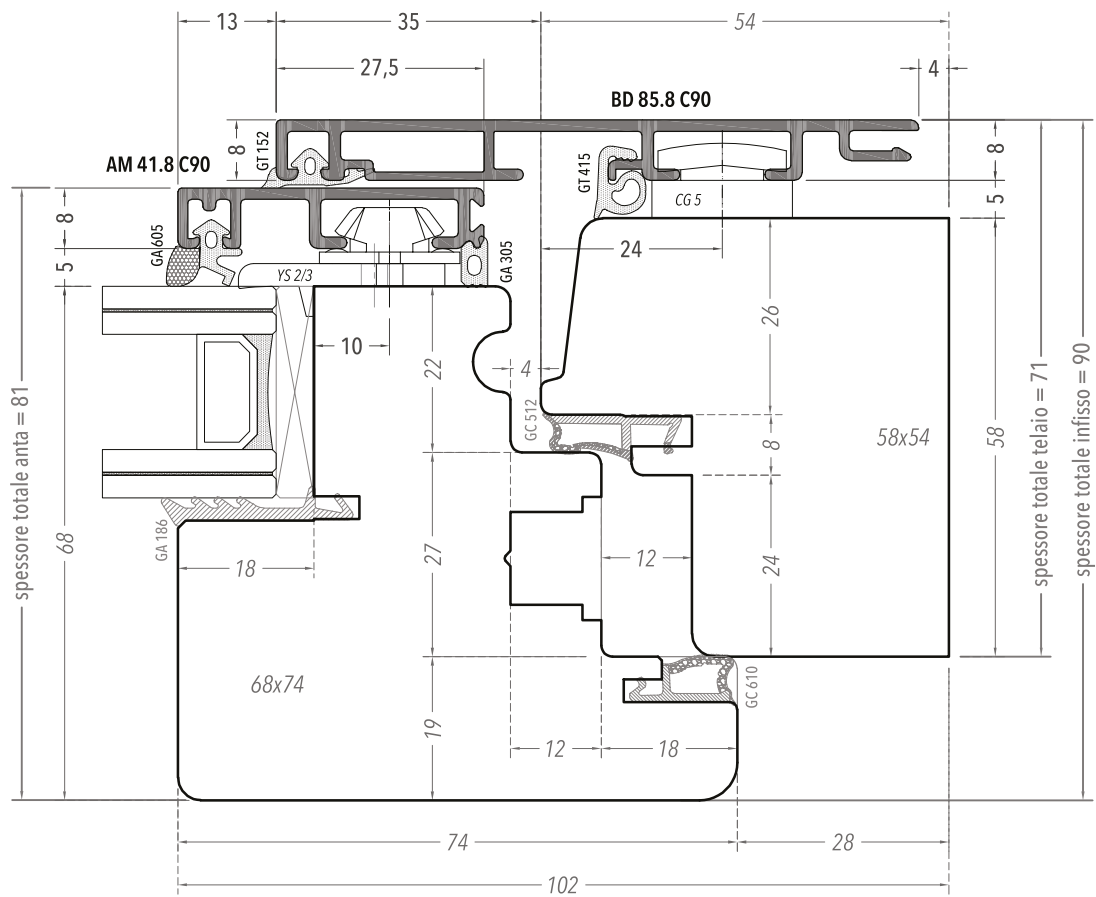



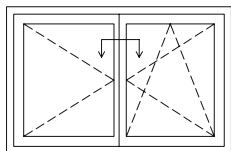

**FINESTRA**

SEZIONE ORIZZONTALE  
 NODO CENTRALE  
 SCALA 1:1

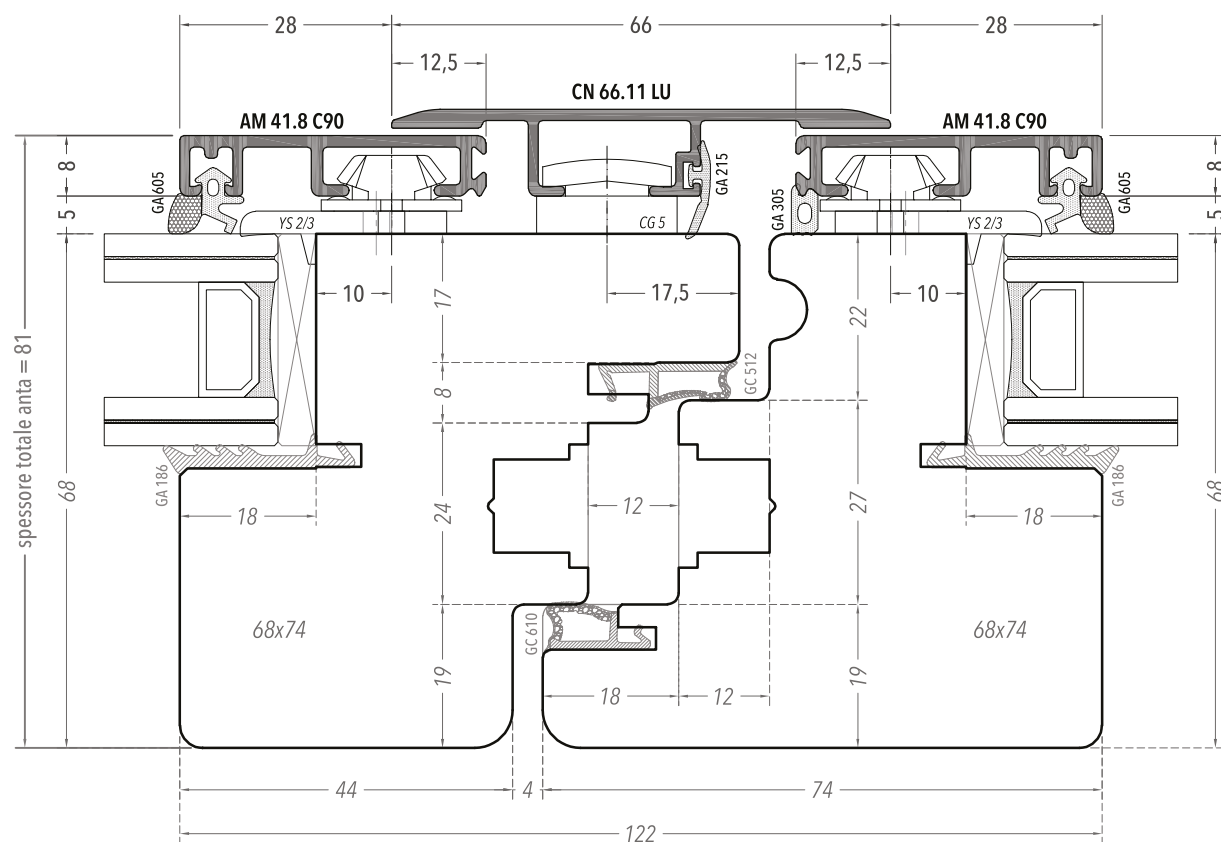

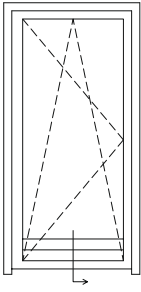

**PORTAFINESTRA**

SEZIONE VERTICALE  
NODO INFERIORE  
SCALA 1:1

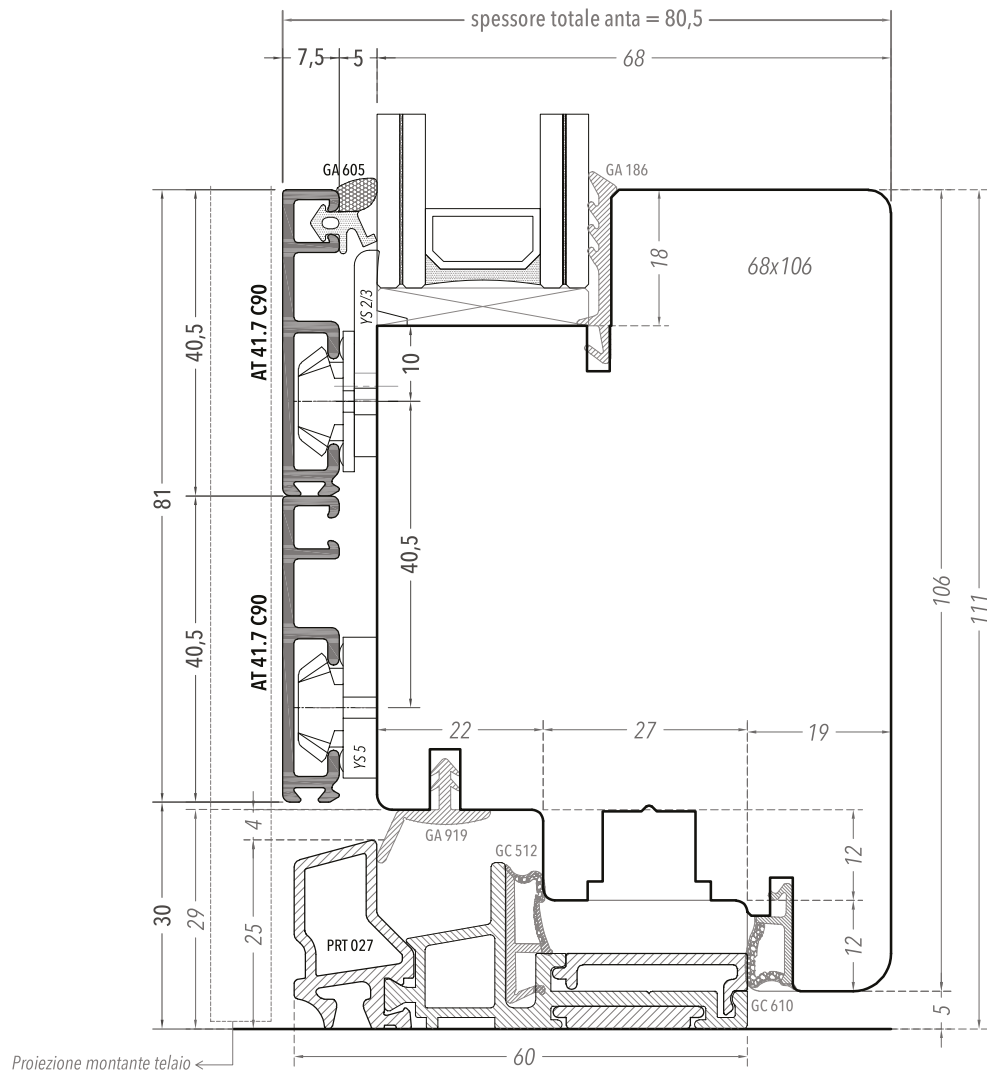





Spessore telaio 70  
Spessore anta 80

# Bridge Easy

---

SLIM HP80

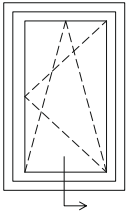

**FINESTRA**

SEZIONE VERTICALE  
NODO INFERIORE  
SCALA 1:1

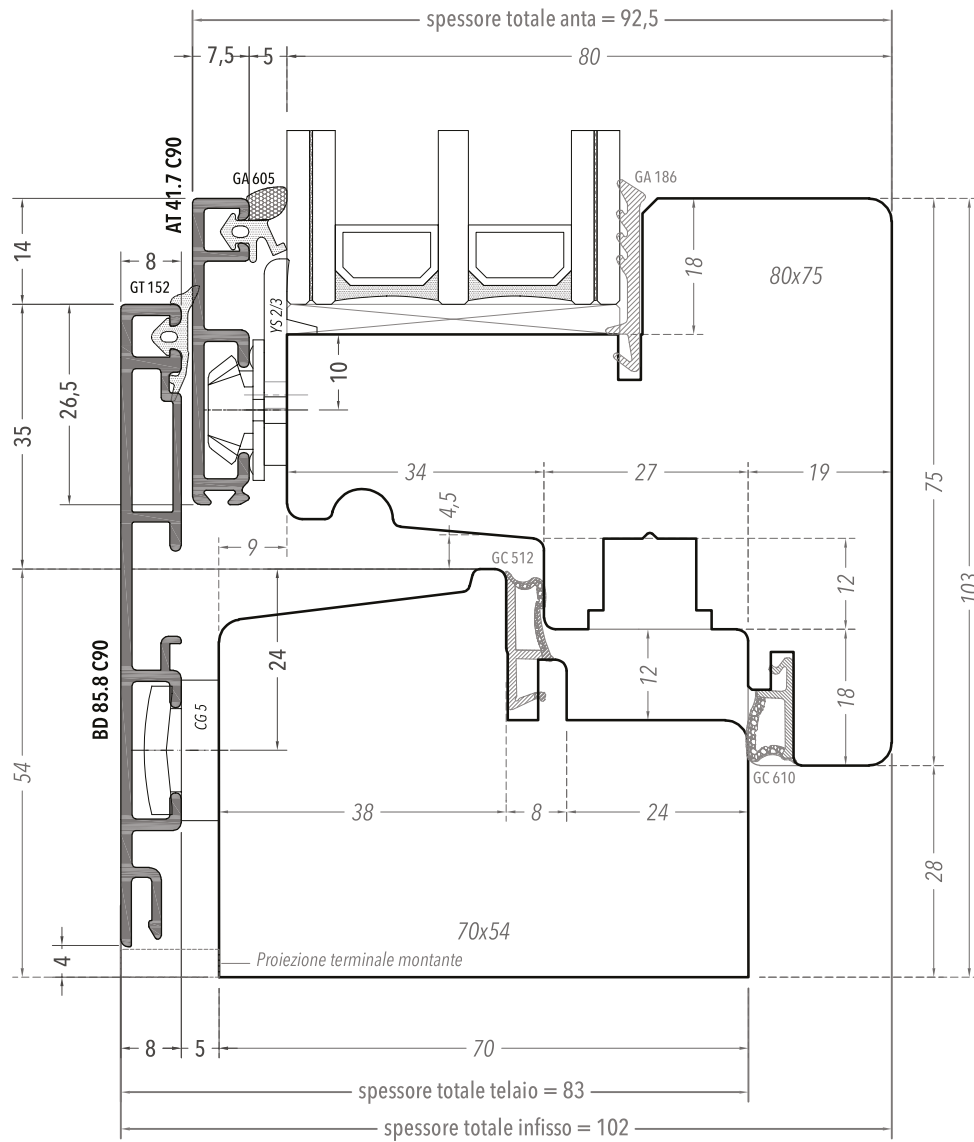

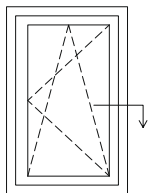

**FINESTRA**

SEZIONE ORIZZONTALE  
 NODO LATERALE  
 SCALA 1:1

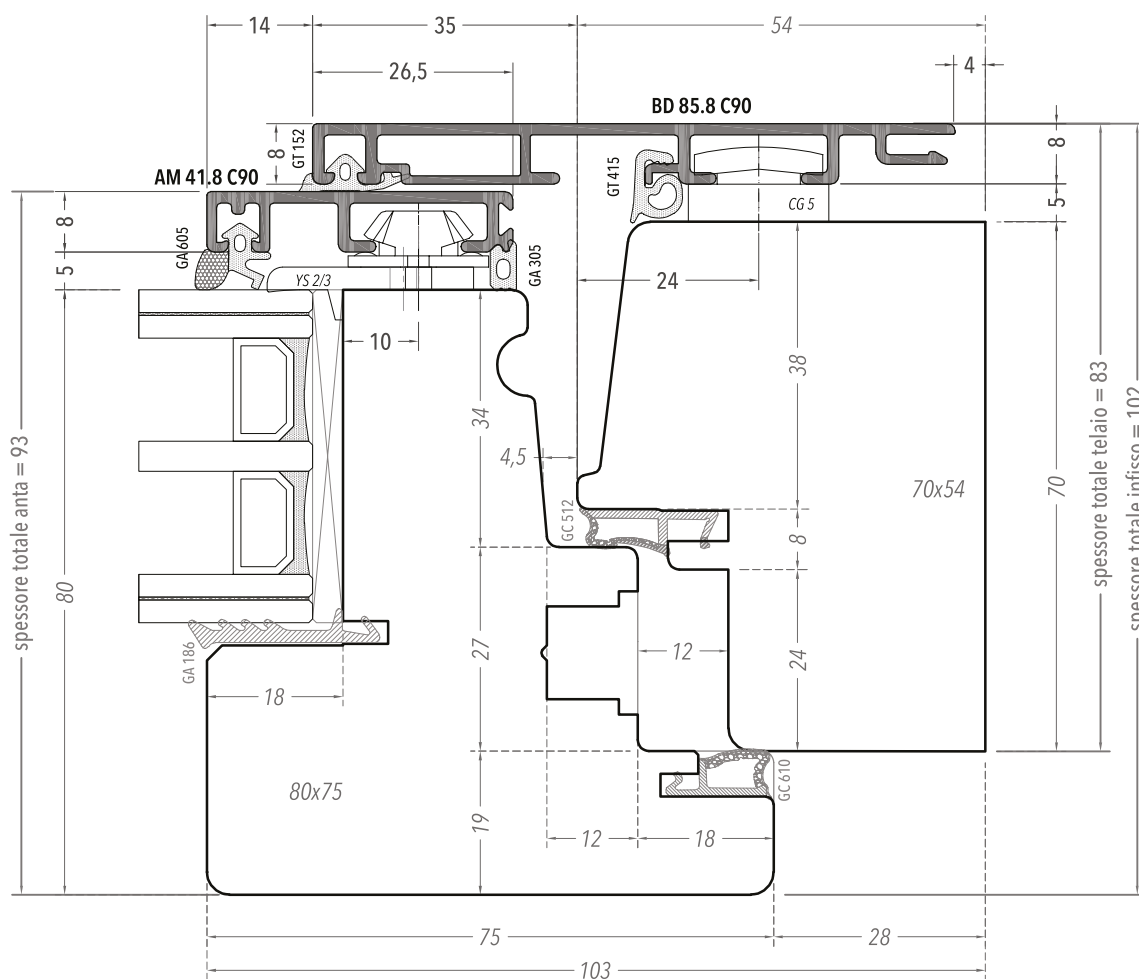

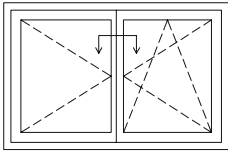

**FINESTRA**

SEZIONE ORIZZONTALE  
 NODO CENTRALE  
 SCALA 1:1

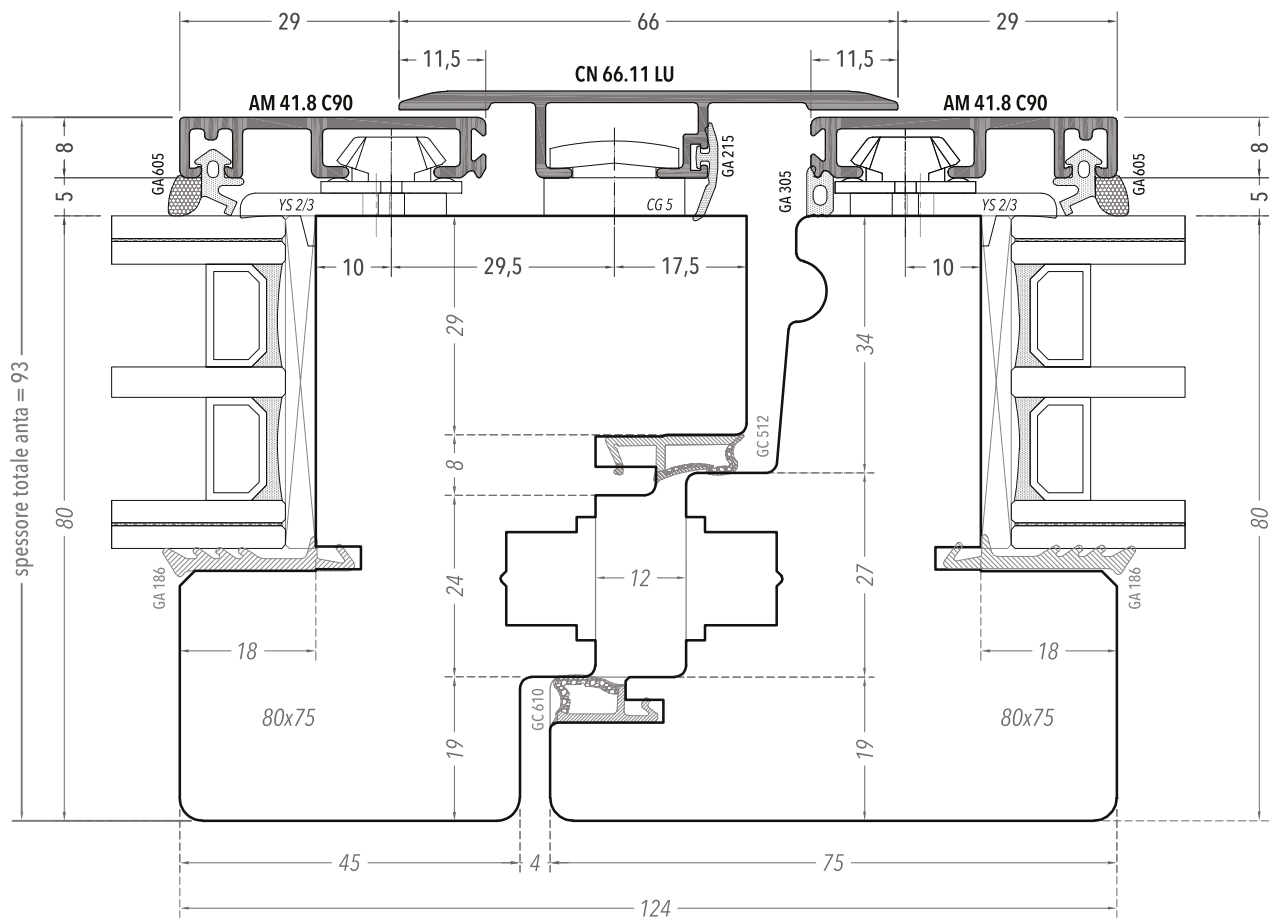



**PORTAFINESTRA**

SEZIONE VERTICALE  
NODO INFERIORE  
SCALA 1:1

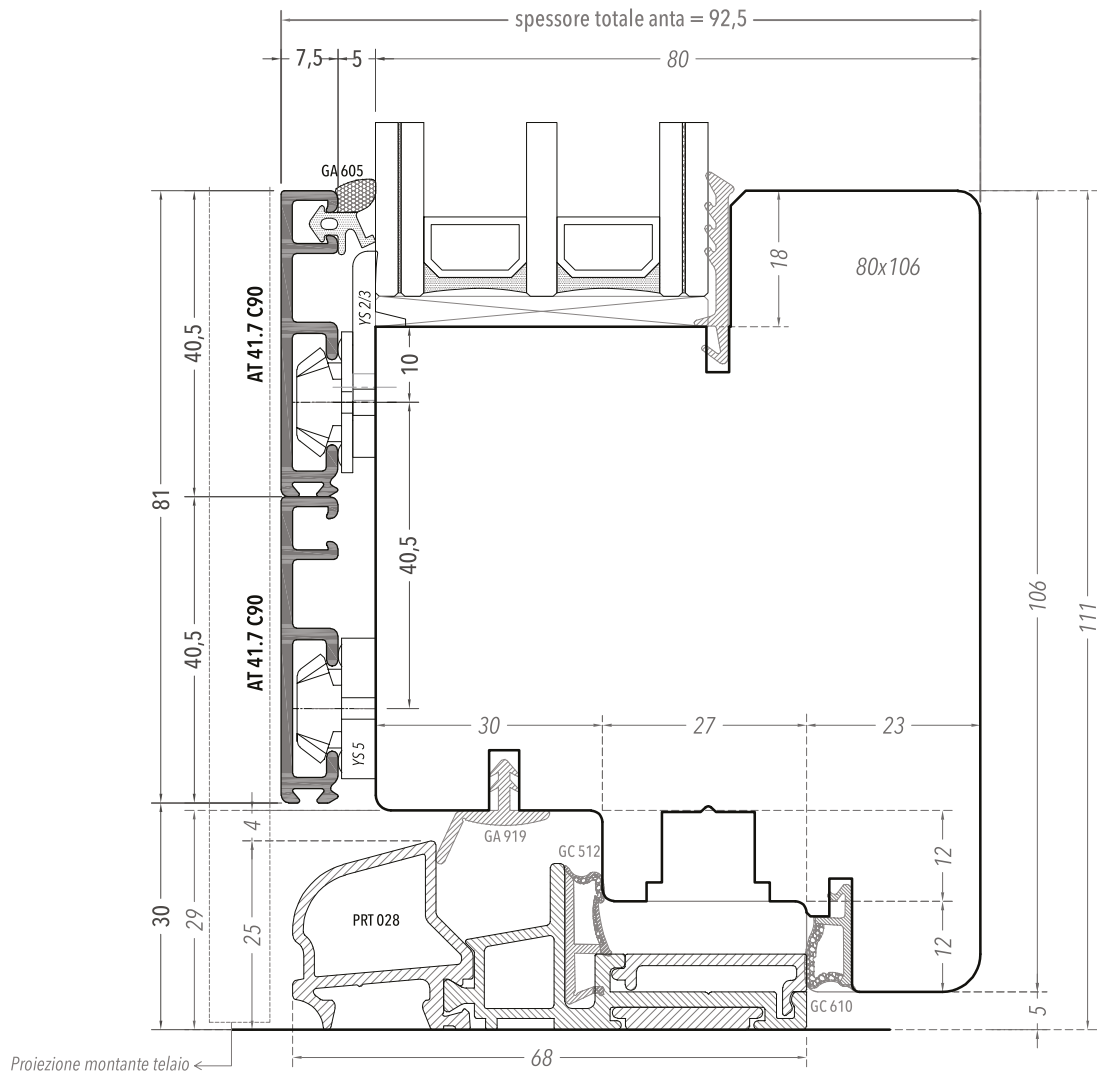
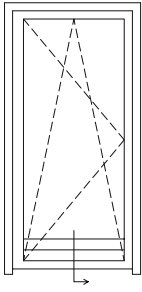



Spessore telaio 68  
Spessore anta 68

# Bridge Alumfast

---

STANDARD



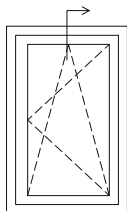

**FINESTRA**

SEZIONE VERTICALE  
NODO SUPERIORE  
SCALA 1:1

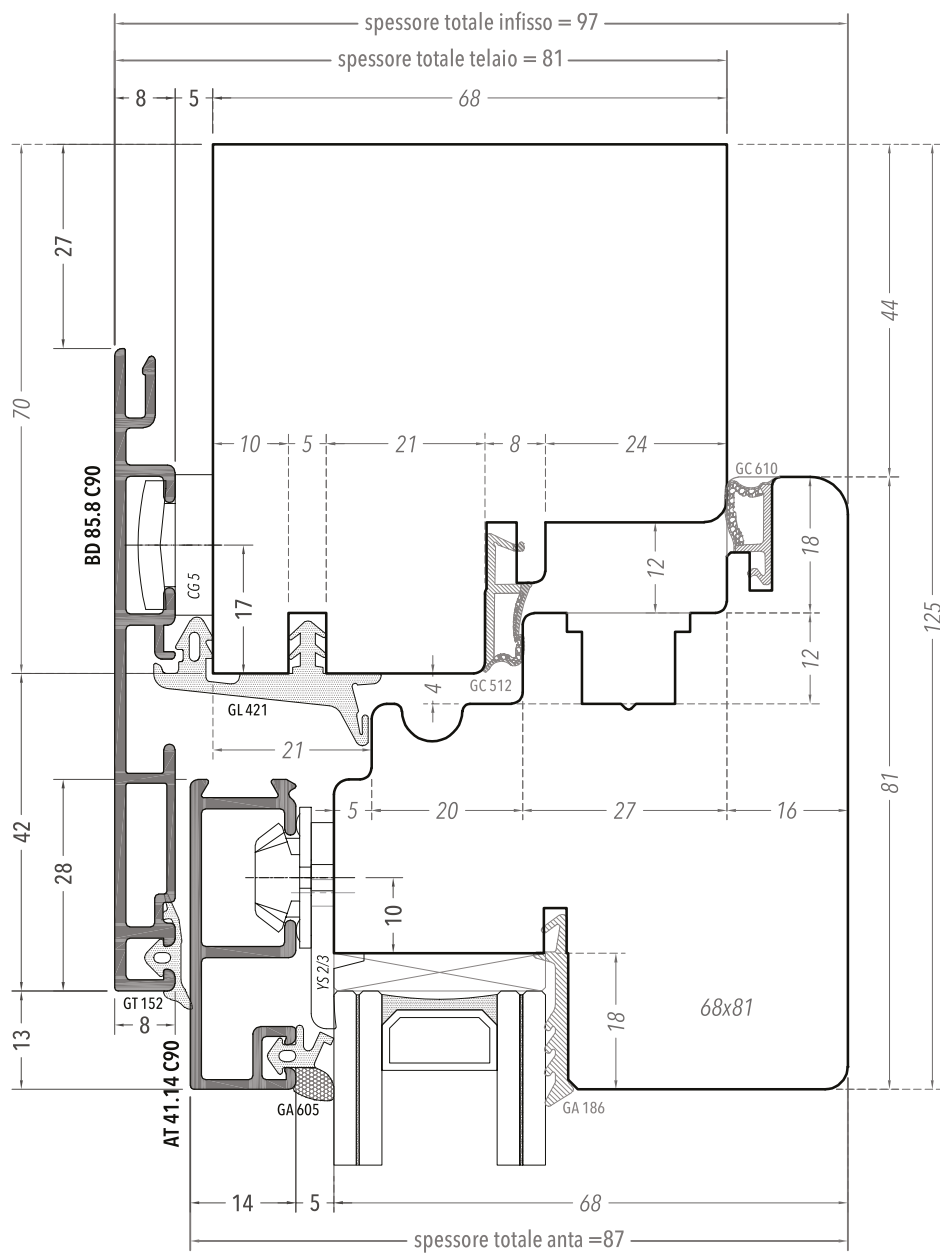
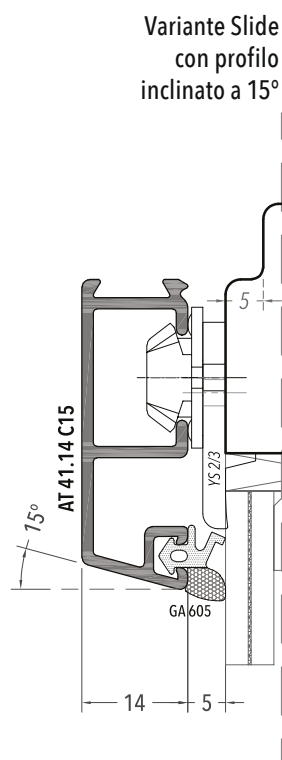

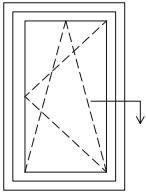

**FINESTRA**

SEZIONE ORIZZONTALE  
 NODO LATERALE  
 SCALA 1:1

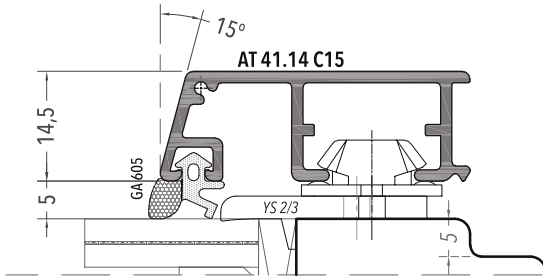

Variante Slide  
 con profilo  
 inclinato a 15°

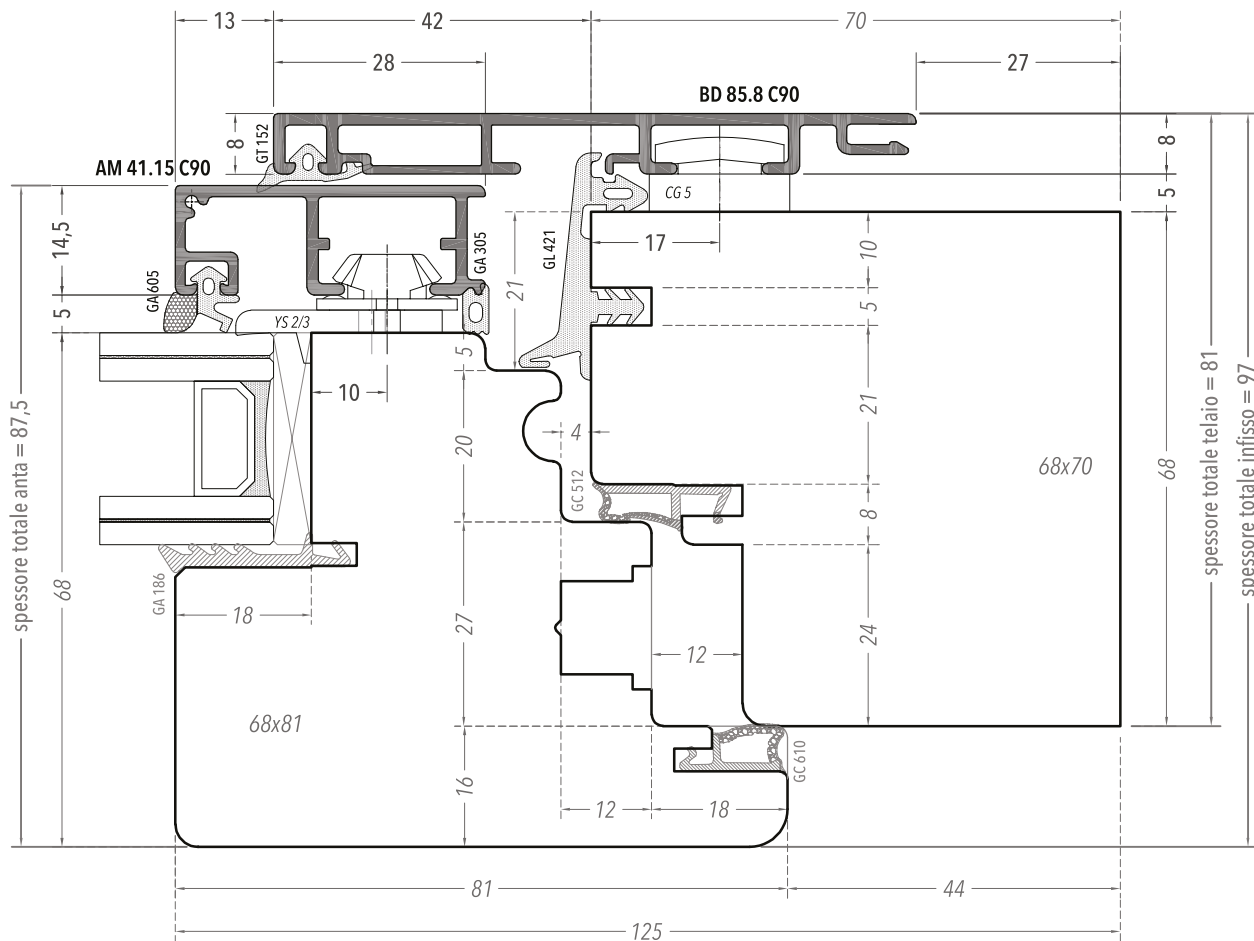

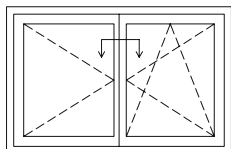

**FINESTRA**

SEZIONE ORIZZONTALE  
NODO CENTRALE  
SCALA 1:1

Variante Slide  
con profilo  
inclinato a 15°

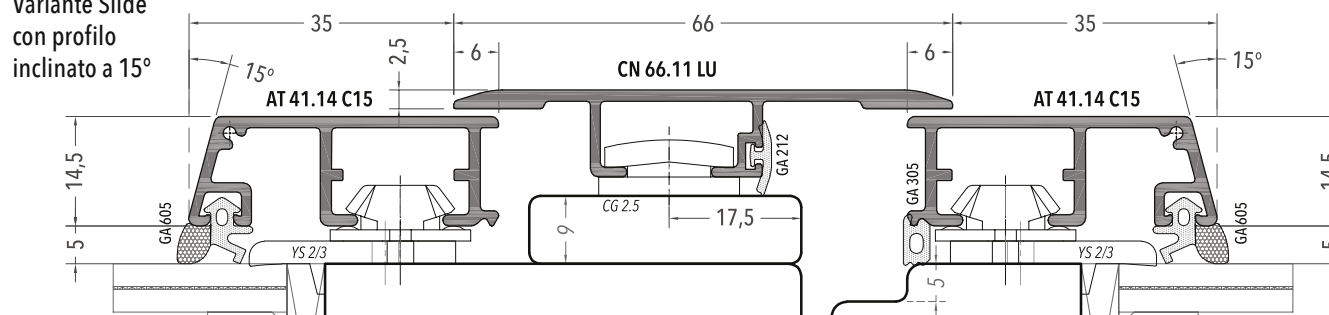

Variante con  
guarnizione  
GL421

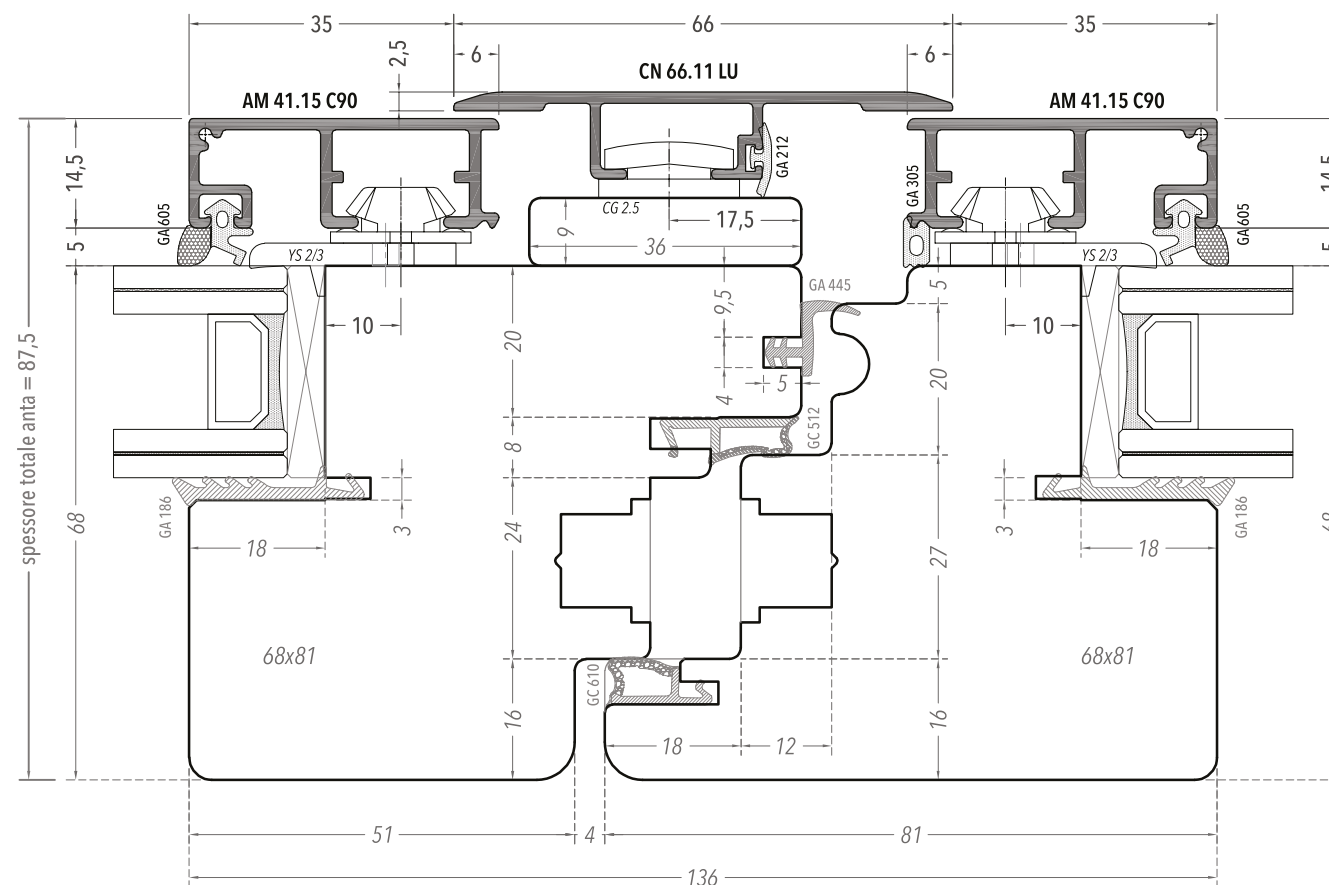
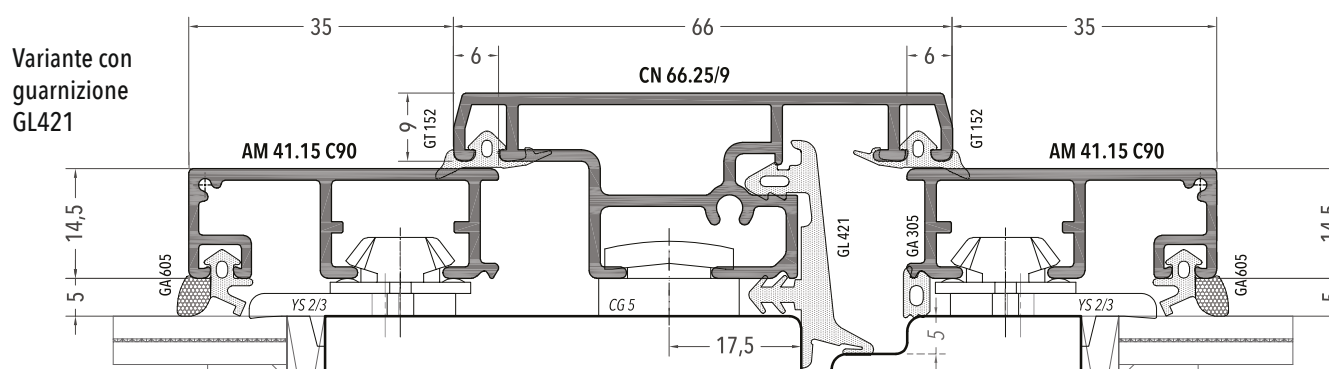

Per il disegno del nodo con montantino aggiunto, consulta la pagina del montantino Sistema 21 Standard.





**APRIBILE CON SOTTO-LUCE**

SEZIONE VERTICALE  
NODO ABBINAMENTO  
SCALA 1:1

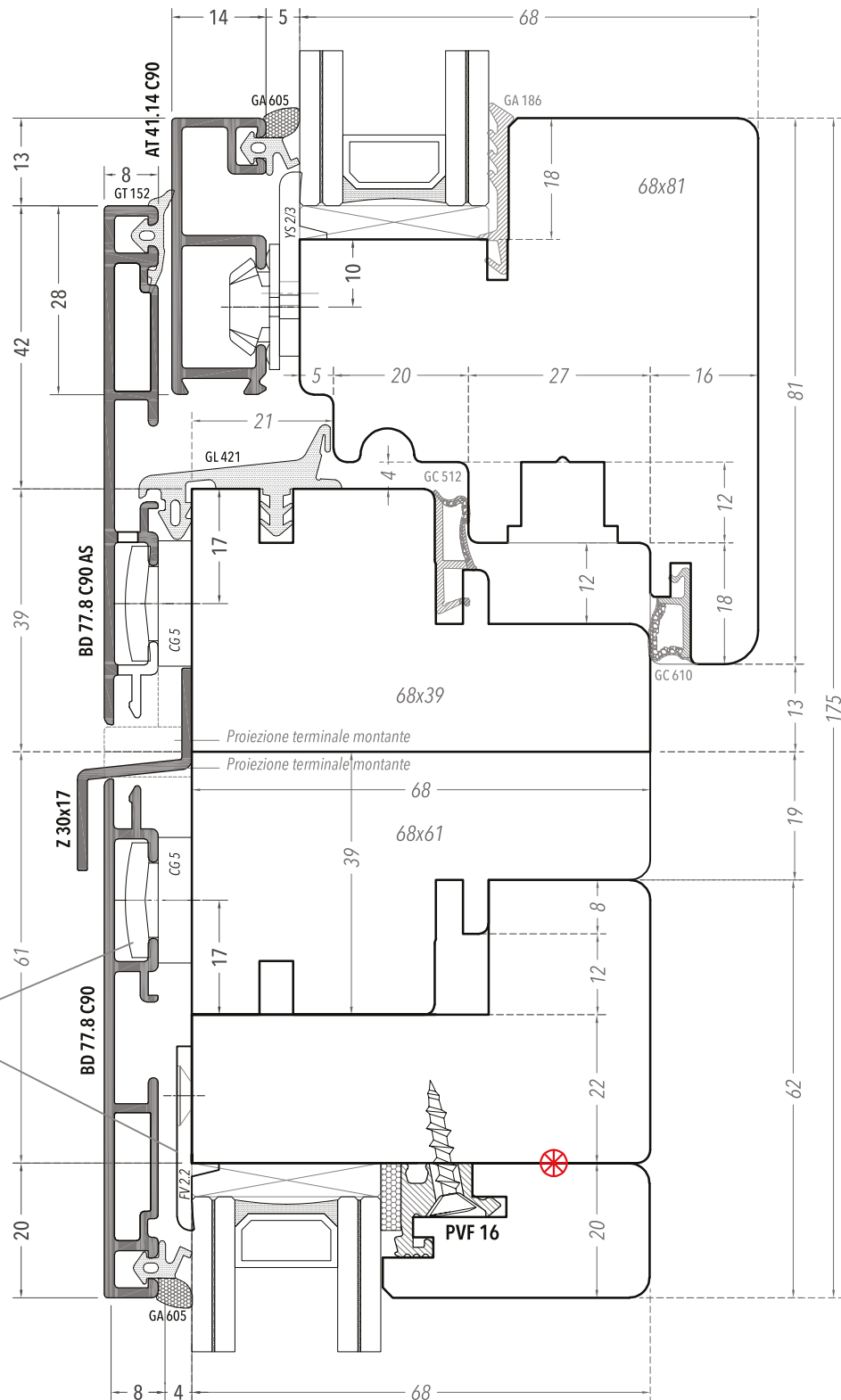
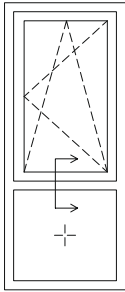

Alternare alla clip girevole una basetta fermavetro auto-posizionante FV 2.2

 Siliconatura dei listelli in legno

Il profilo Z3x17 verrà fornito con una lunghezza pari all'esterno telaio. Dovrà essere tagliato a misura luce interna montanti telaio in alluminio. Soluzione consigliata per abbinamenti di grandi dimensioni.

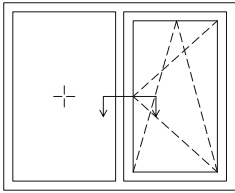

**FINESTRA CON FIANCO-LUCE**

SEZIONE ORIZZONTALE  
NODO ABBINAMENTO  
SCALA 1:1

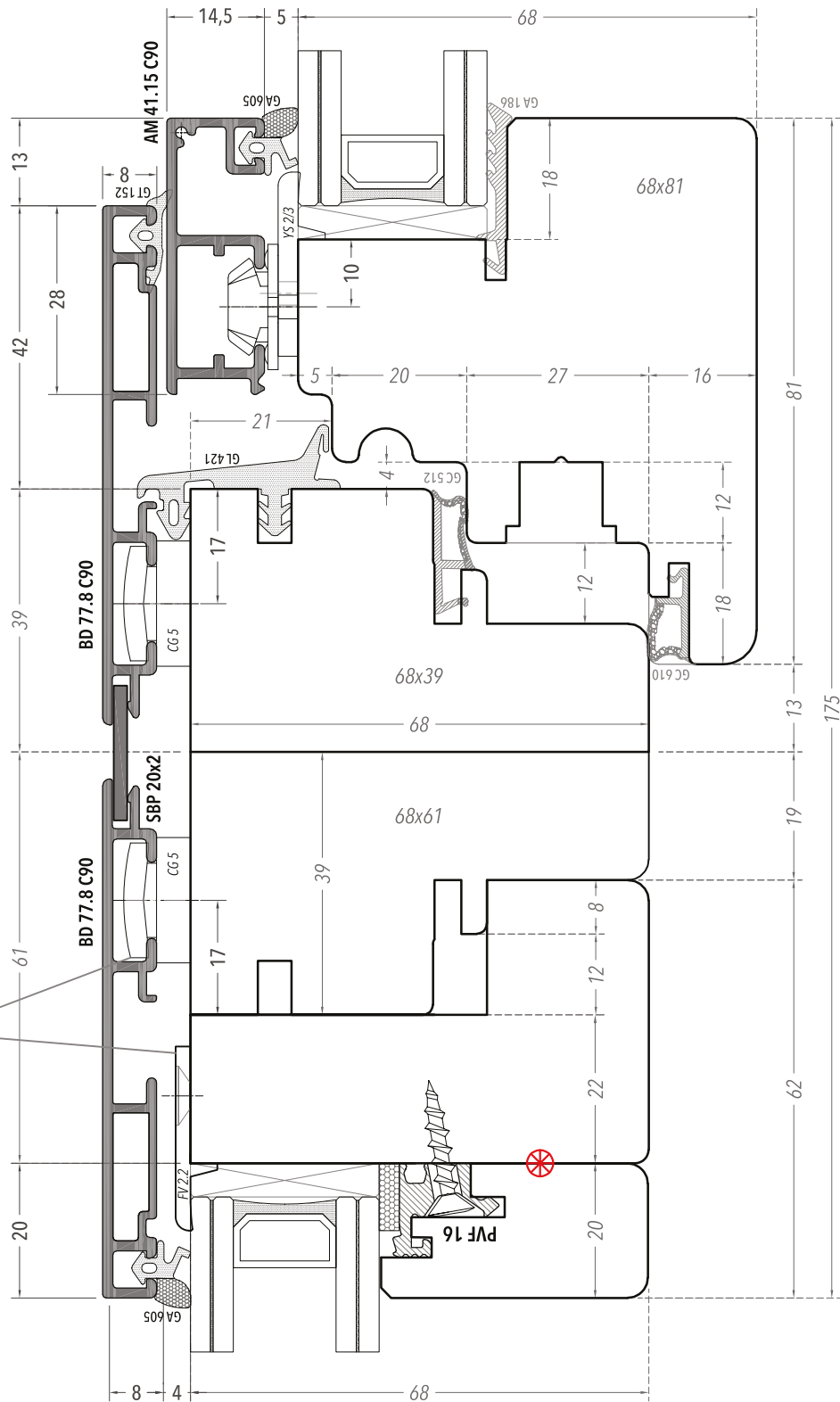

Alternare alla clip girevole una basetta fermavetro auto-posizionante FV 2.2

 Siliconatura dei listelli in legno

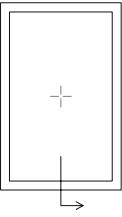

**FISSO**  
SEZIONE VERTICALE  
NODO INFERIORE  
SCALA 1:1

 Siliconatura dei listelli in legno

Alternare alla clip  
girevole una bassetta  
fermavetro  
auto-posizionante FV 2.2

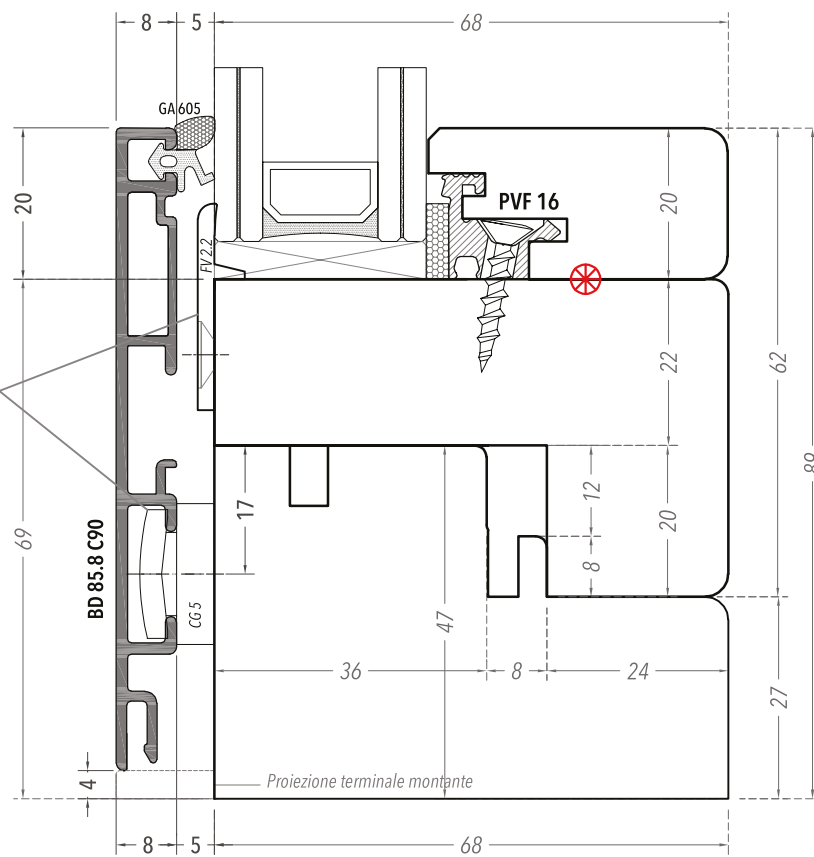

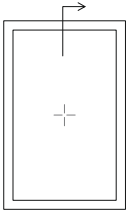

**FISSO**

SEZIONE VERTICALE  
NODO SUPERIORE  
SCALA 1:1

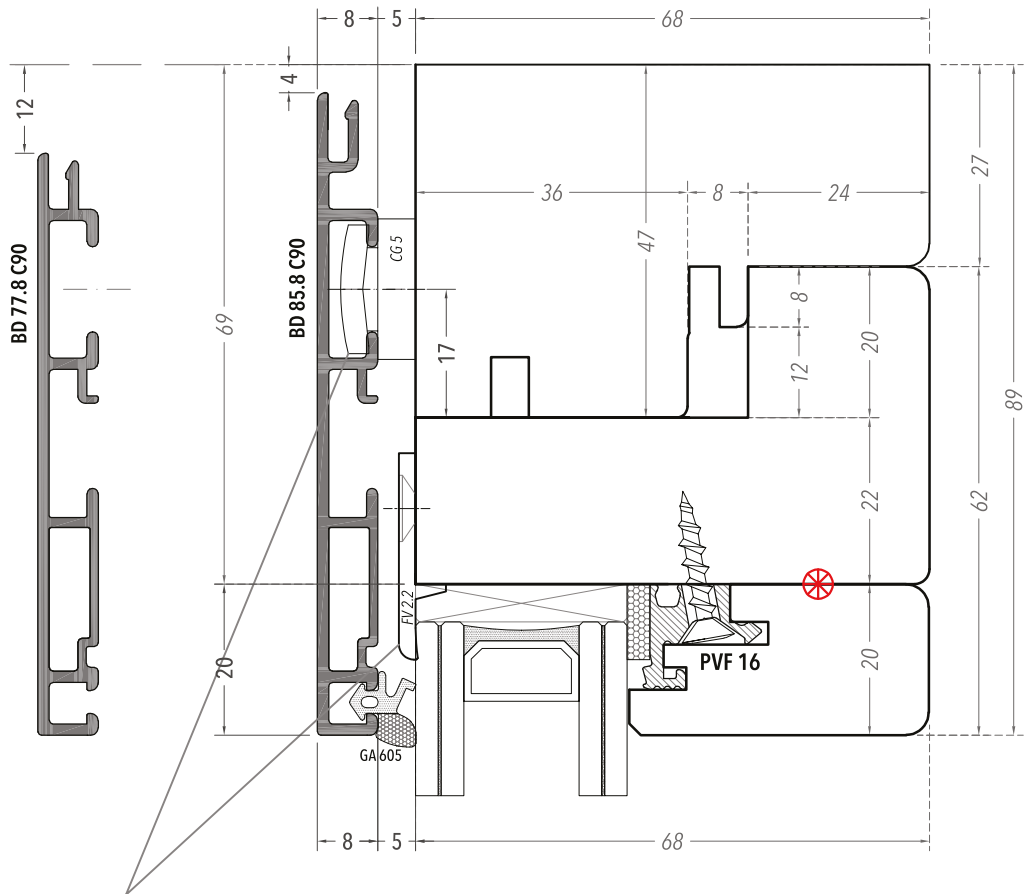

Alternare alla clip girevole una basetta  
fermavetro auto-posizionante FV 2.2

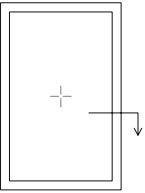

**FISSO**  
SEZIONE ORIZZONTALE  
NODO LATERALE  
SCALA 1:1

 Siliconatura dei listelli in legno

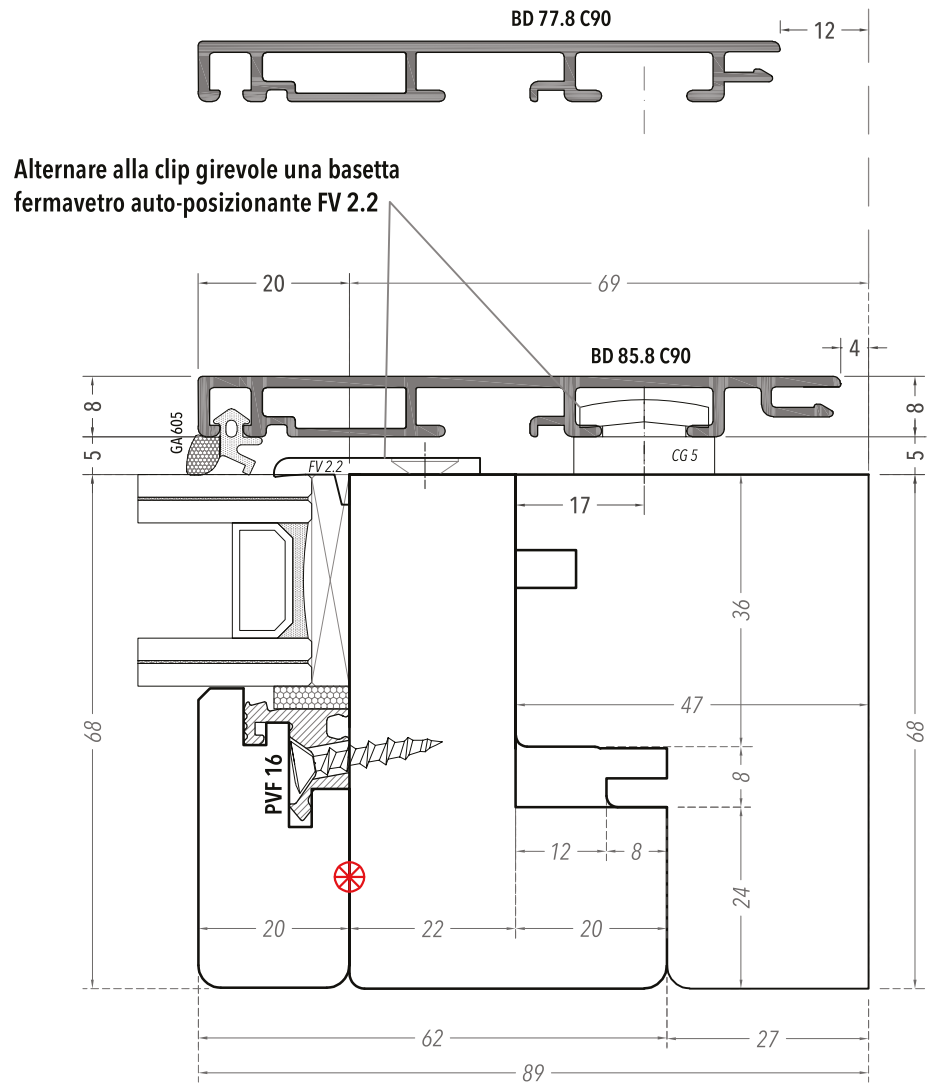

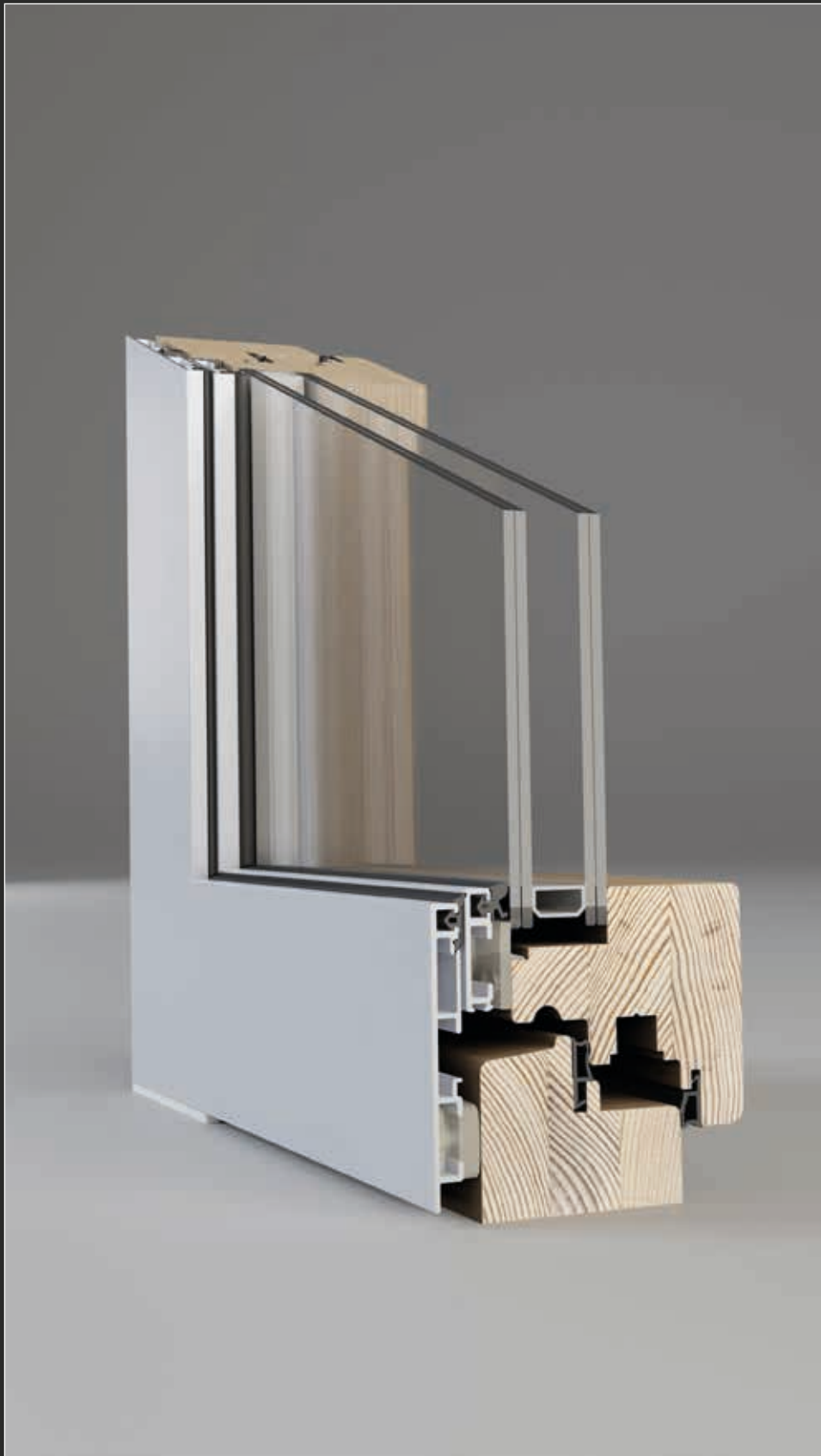

Spessore telaio 58  
Spessore anta 68

# Bridge Grace

---

STANDARD

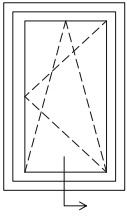

**FINESTRA**

SEZIONE VERTICALE  
 NODO INFERIORE  
 SCALA 1:1

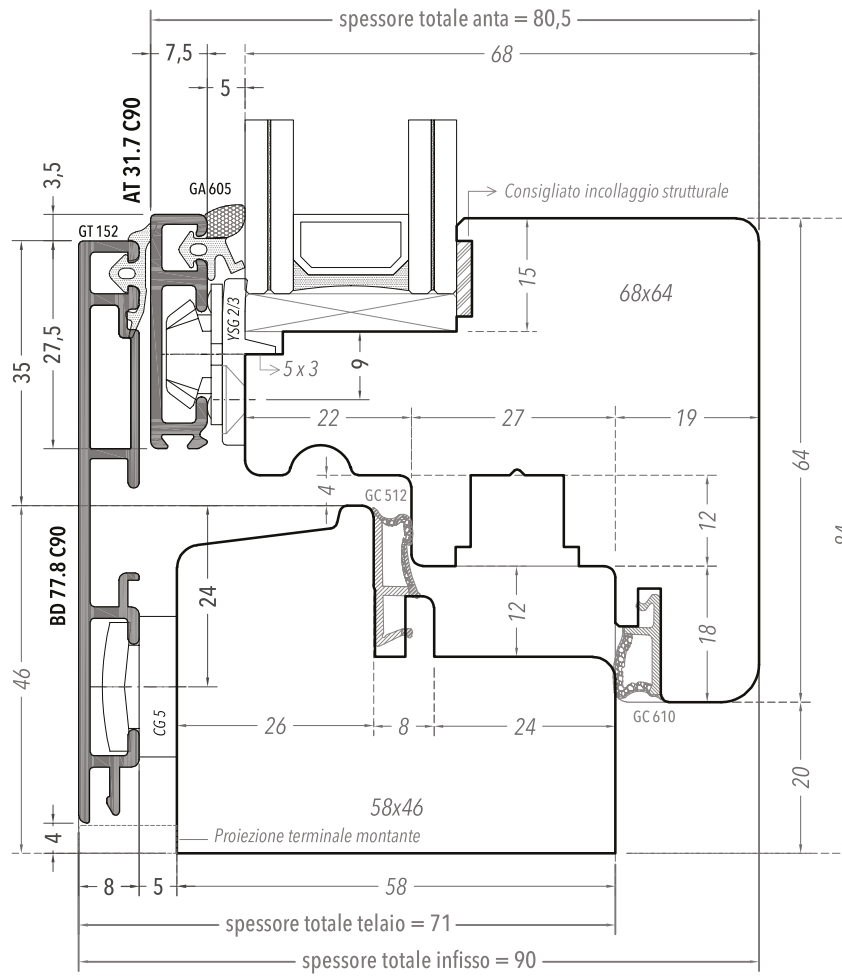



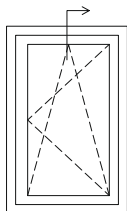

**FINESTRA**

SEZIONE VERTICALE  
 NODO SUPERIORE  
 SCALA 1:1

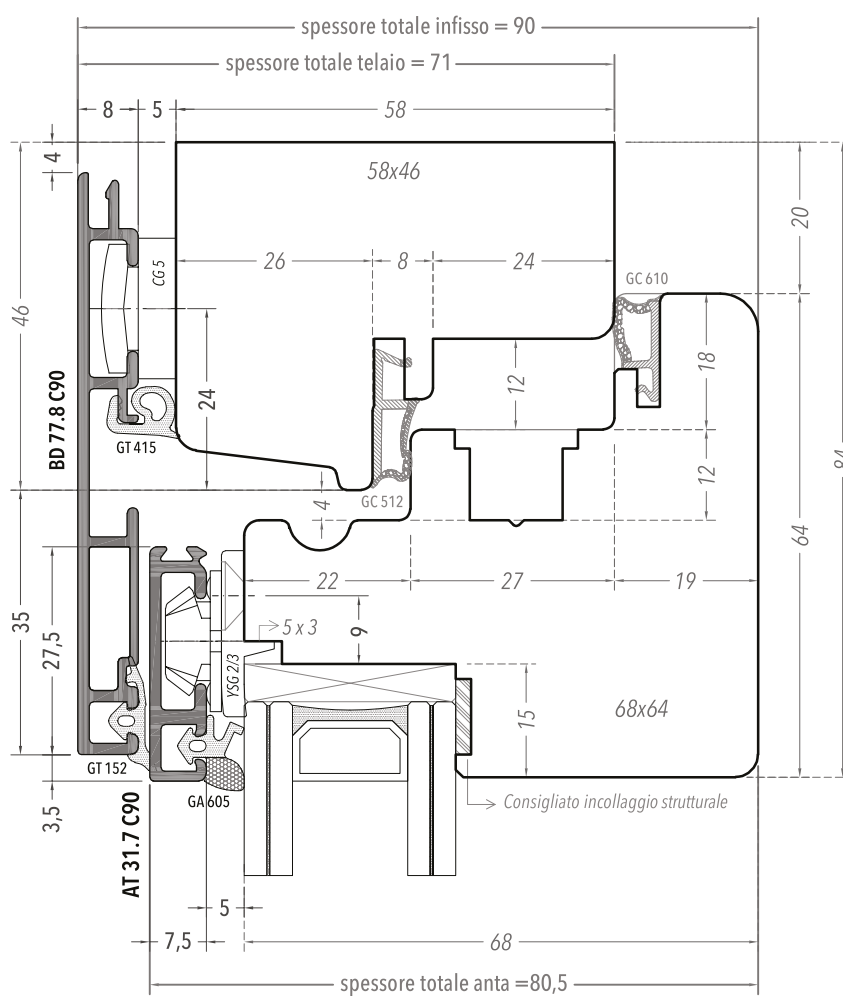

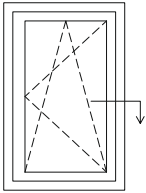

**FINESTRA**

SEZIONE ORIZZONTALE  
 NODO LATERALE  
 SCALA 1:1

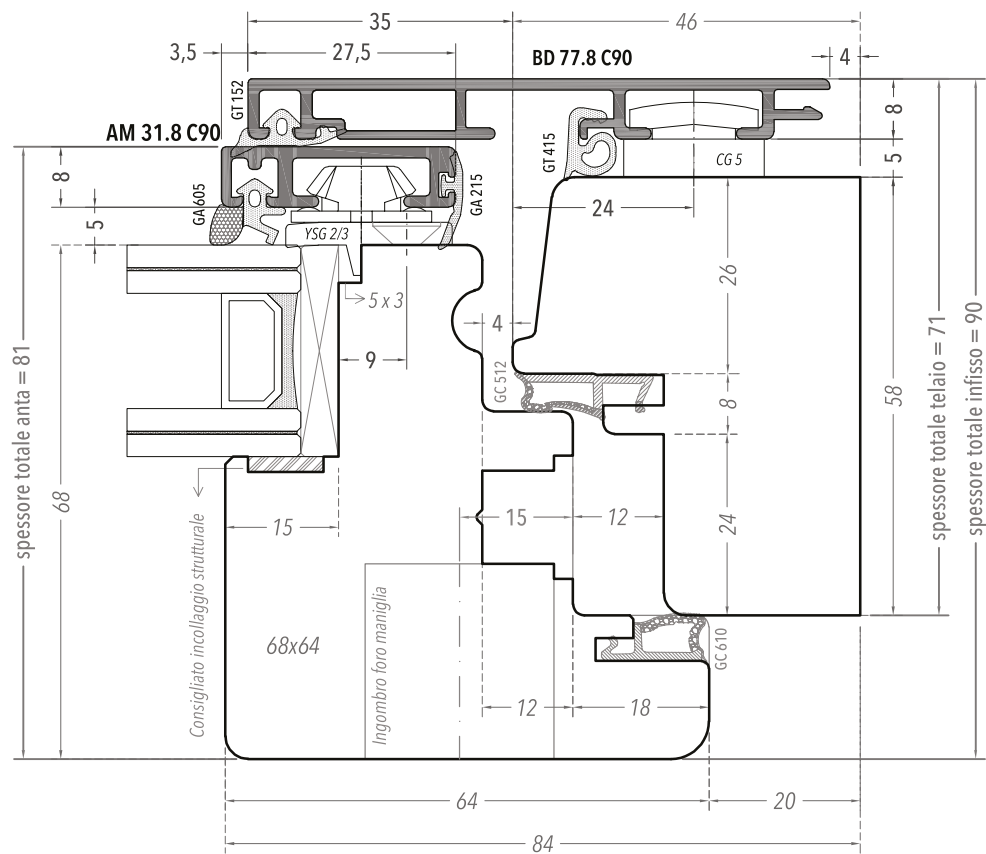

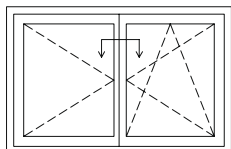

**FINESTRA**

SEZIONE ORIZZONTALE  
 NODO CENTRALE  
 SCALA 1:1

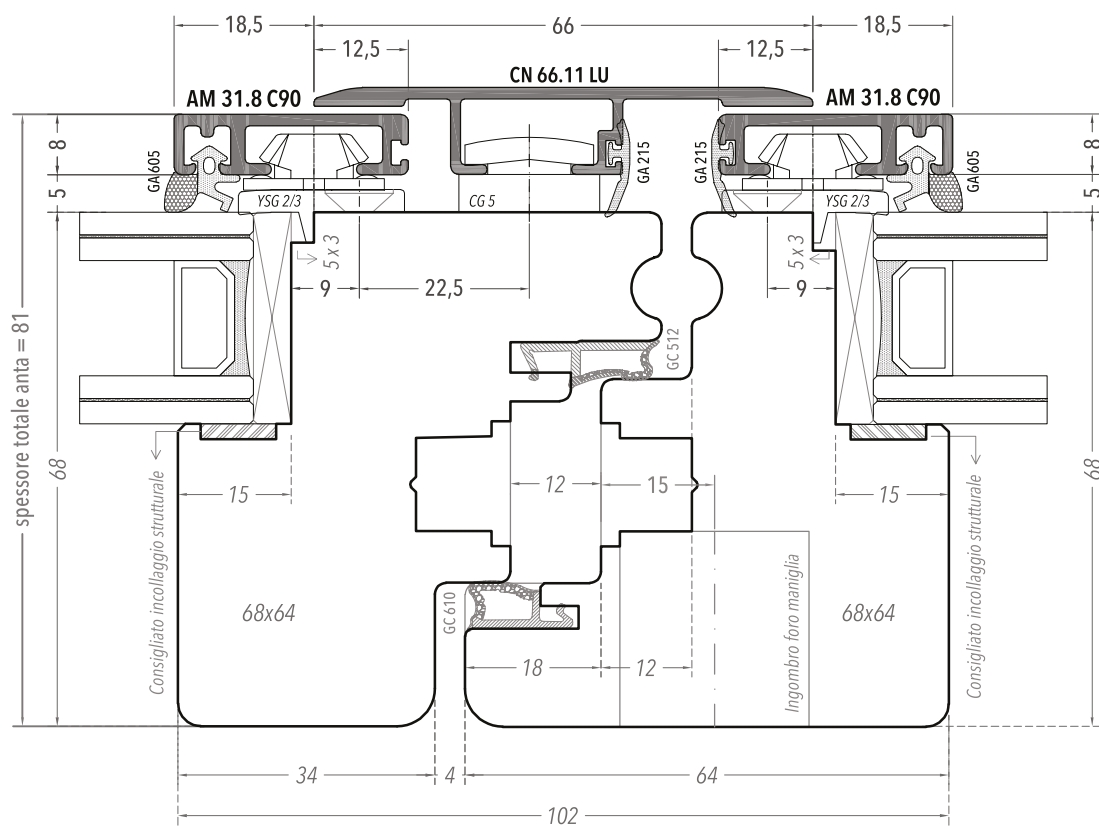

Per il disegno del nodo con montantino aggiunto, consulta la pagina del montantino Bridge Grace.

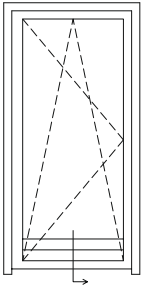

**PORTAFINESTRA**

SEZIONE VERTICALE  
 NODO INFERIORE  
 SCALA 1:1

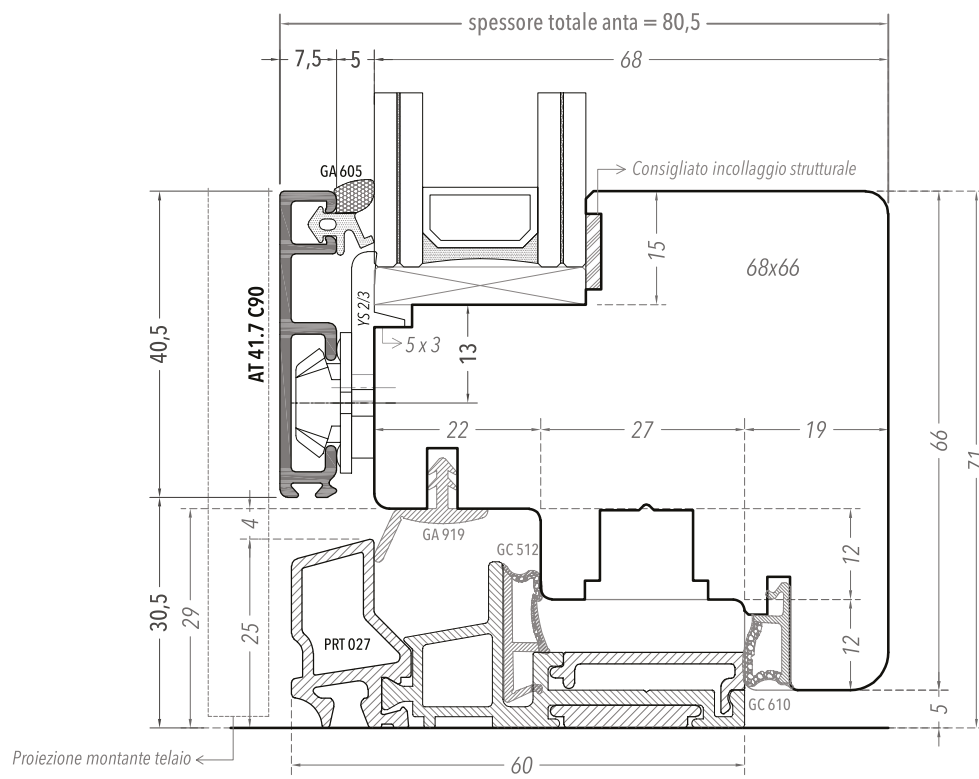





Spessore telaio 68  
Spessore anta 80

# Bridge Grace

---

HP80

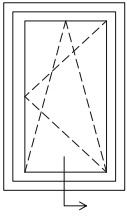

**FINESTRA**

SEZIONE VERTICALE  
 NODO INFERIORE  
 SCALA 1:1

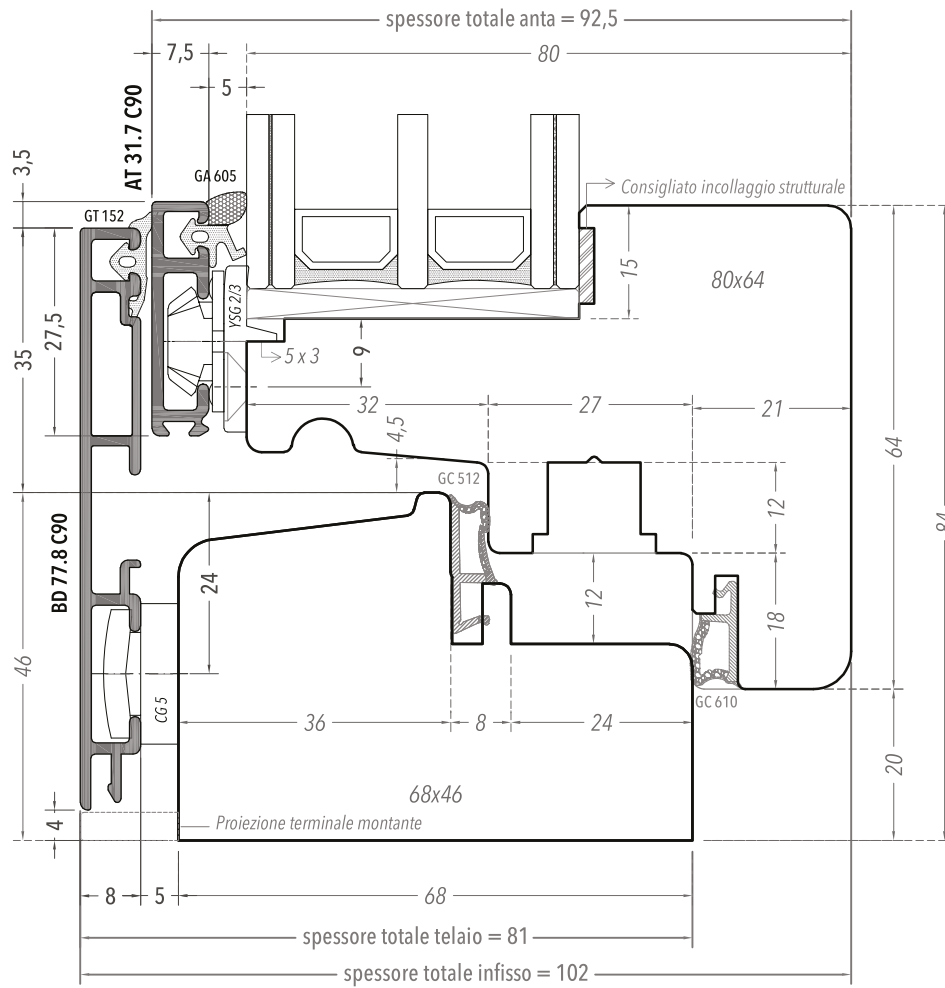



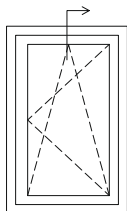

**FINESTRA**

SEZIONE VERTICALE  
 NODO SUPERIORE  
 SCALA 1:1

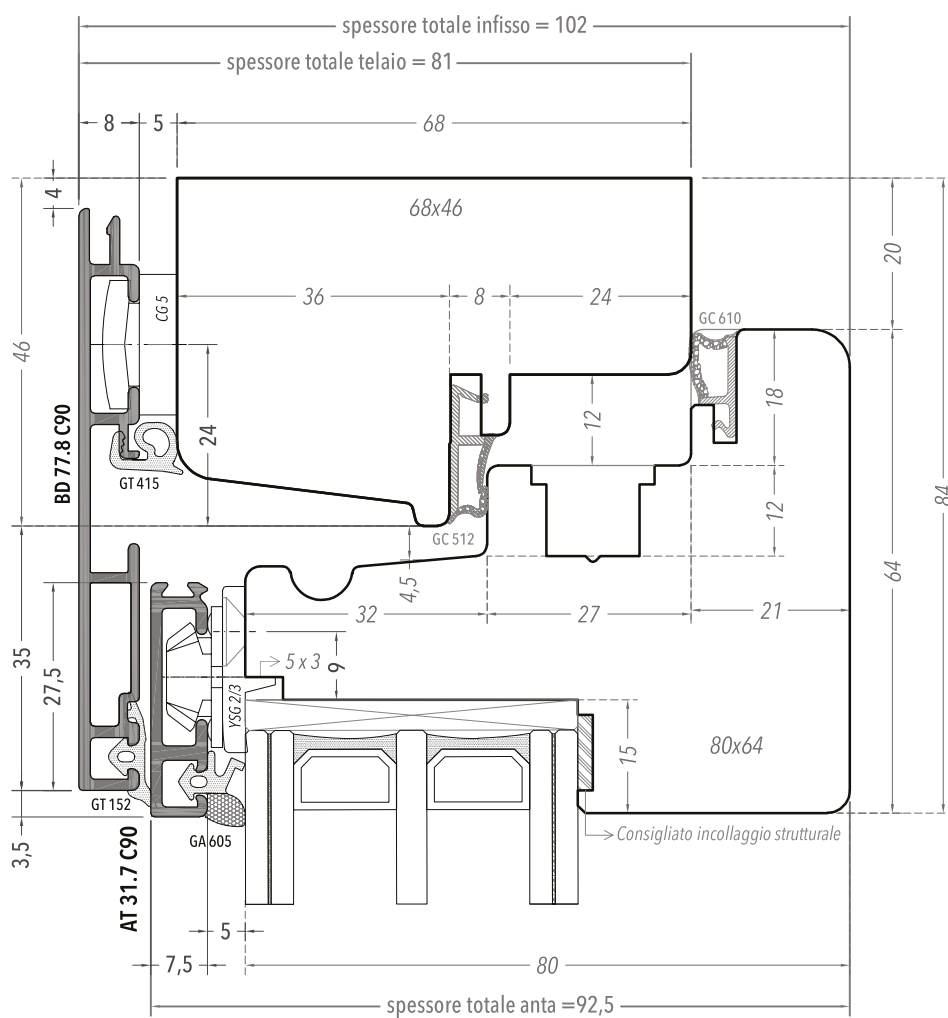

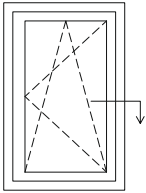

**FINESTRA**

SEZIONE ORIZZONTALE  
 NODO LATERALE  
 SCALA 1:1

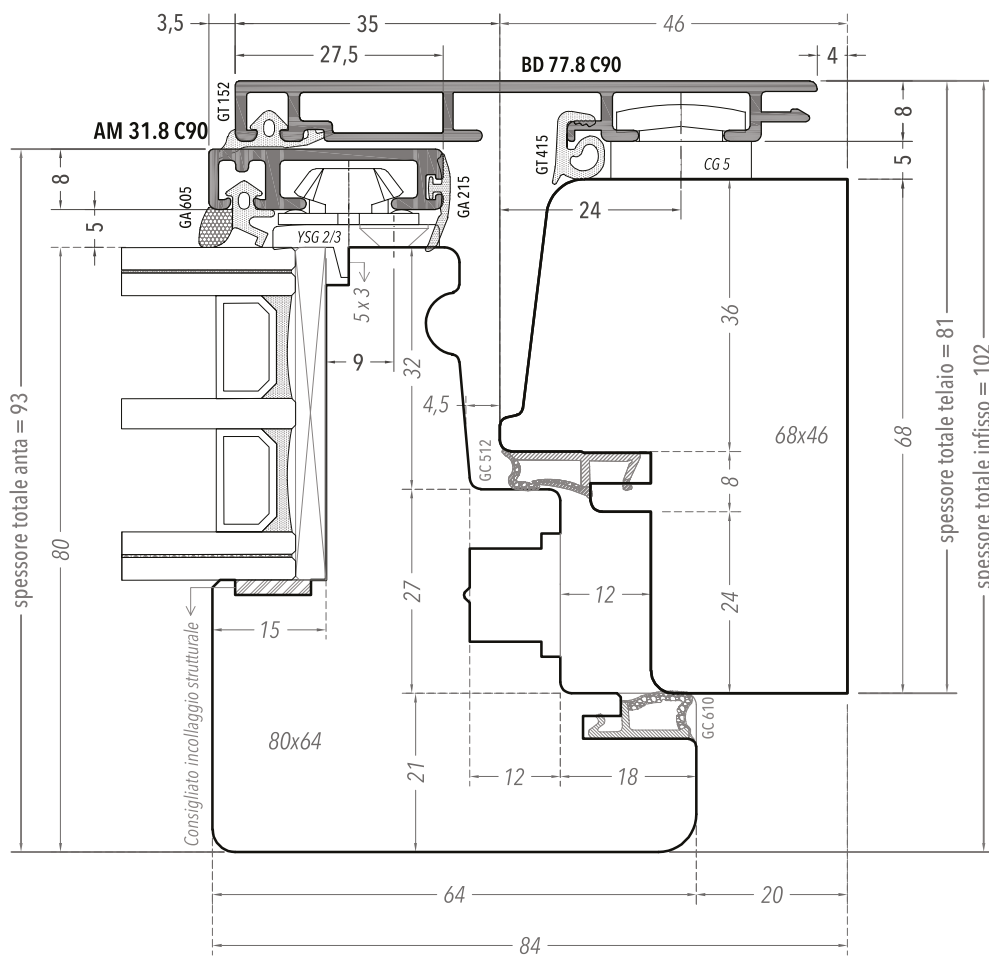

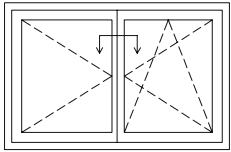

**FINESTRA**  
SEZIONE ORIZZONTALE  
NODO CENTRALE  
SCALA 1:1

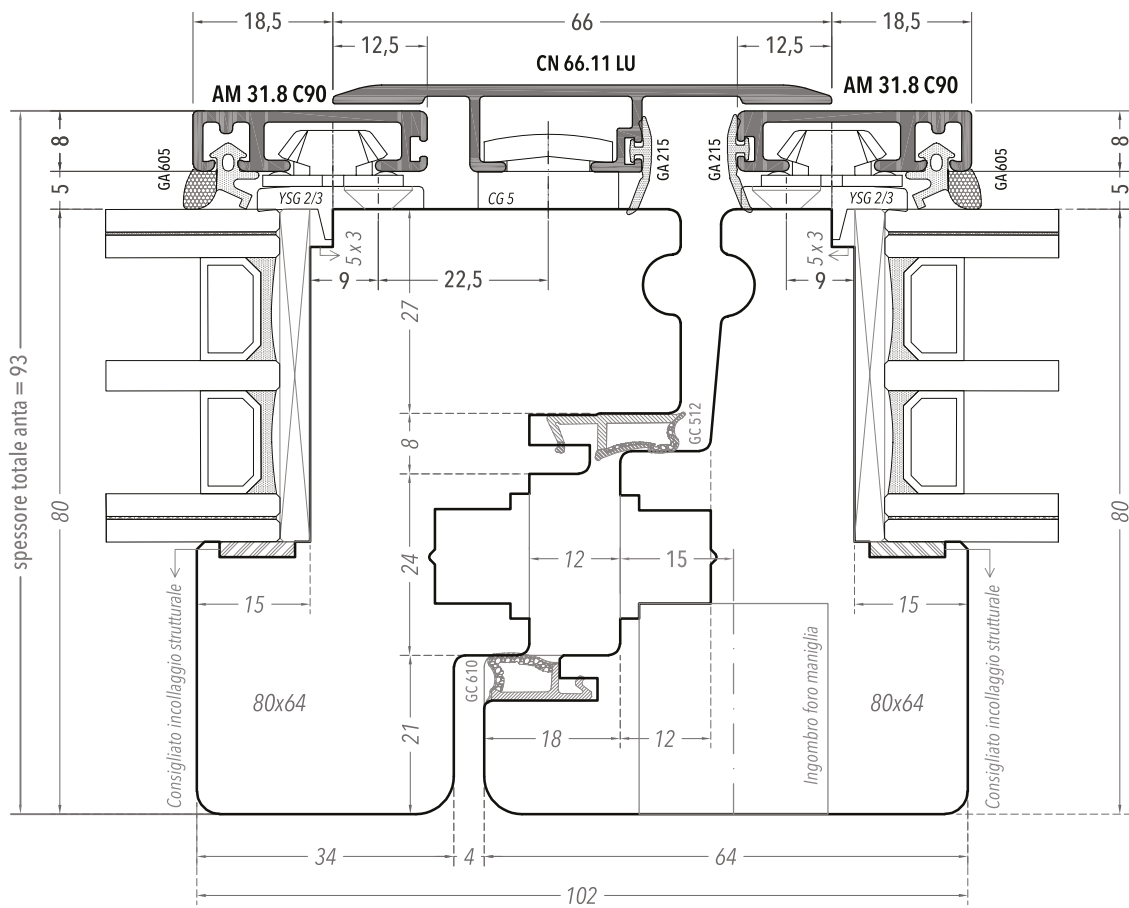

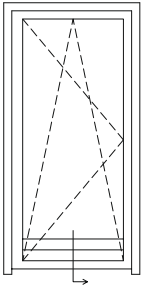

**PORTAFINESTRA**

SEZIONE VERTICALE  
 NODO INFERIORE  
 SCALA 1:1

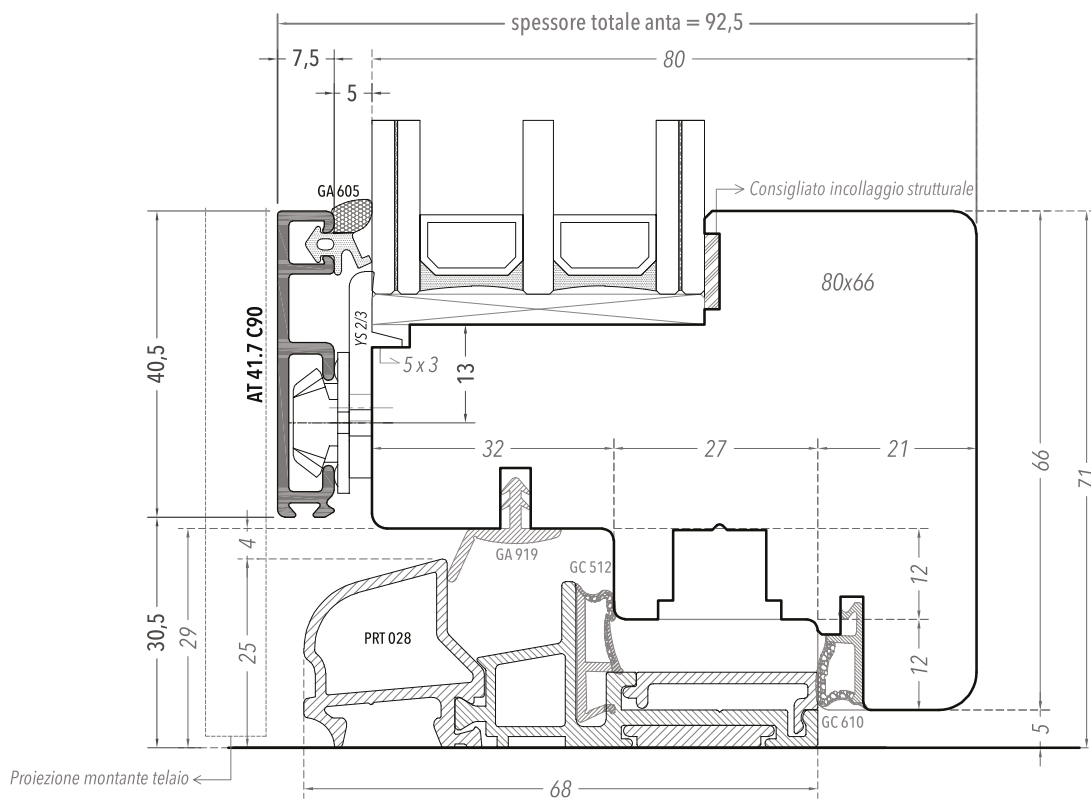





Spessore telaio 78  
Spessore anta 80

# Ghost

---

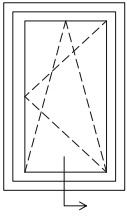

**FINESTRA**

SEZIONE VERTICALE  
 NODO INFERIORE  
 SCALA 1:1

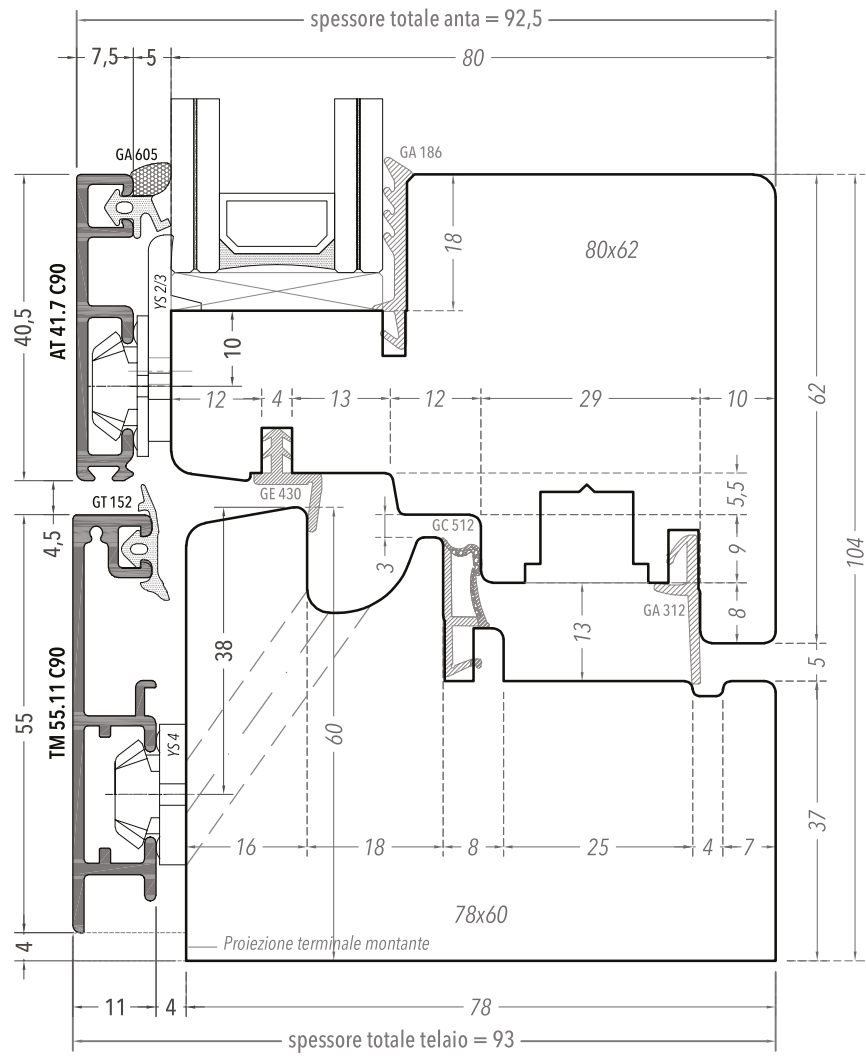



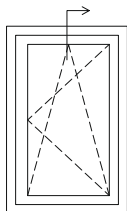

**FINESTRA**  
 SEZIONE VERTICALE  
 NODO SUPERIORE  
 SCALA 1:1

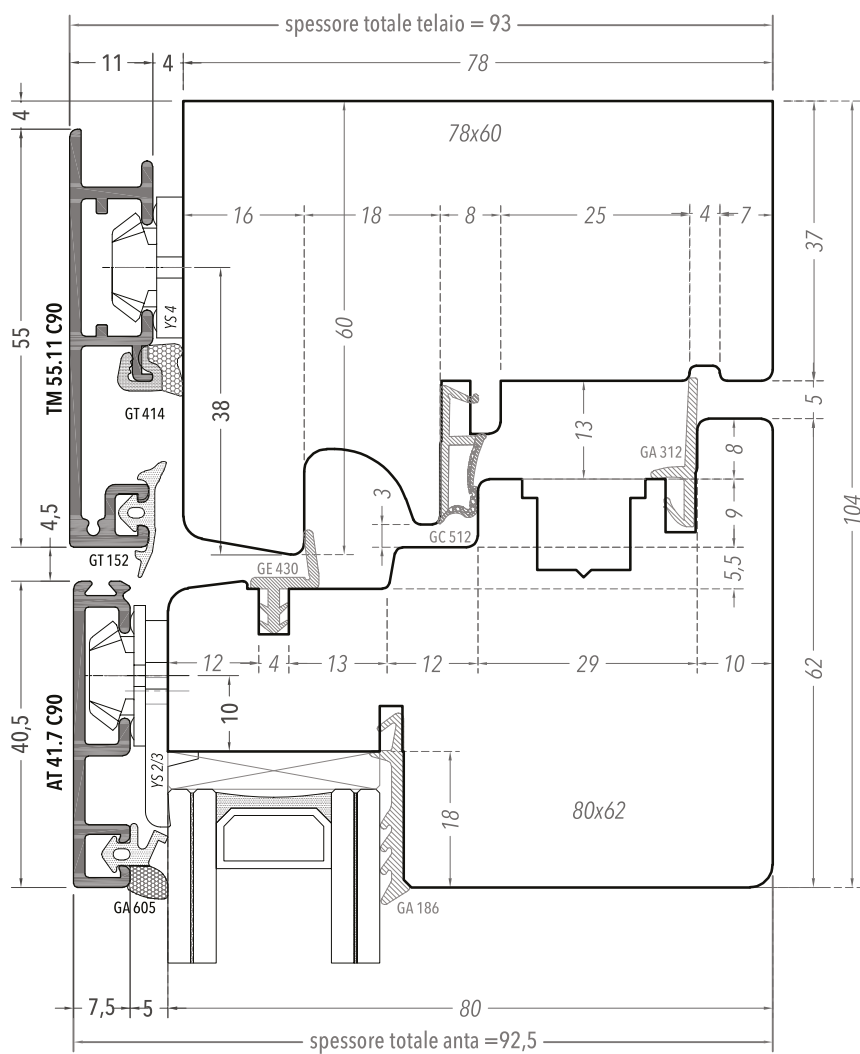

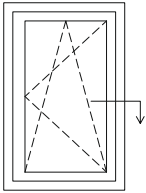

**FINESTRA**

SEZIONE ORIZZONTALE  
 NODO LATERALE  
 SCALA 1:1

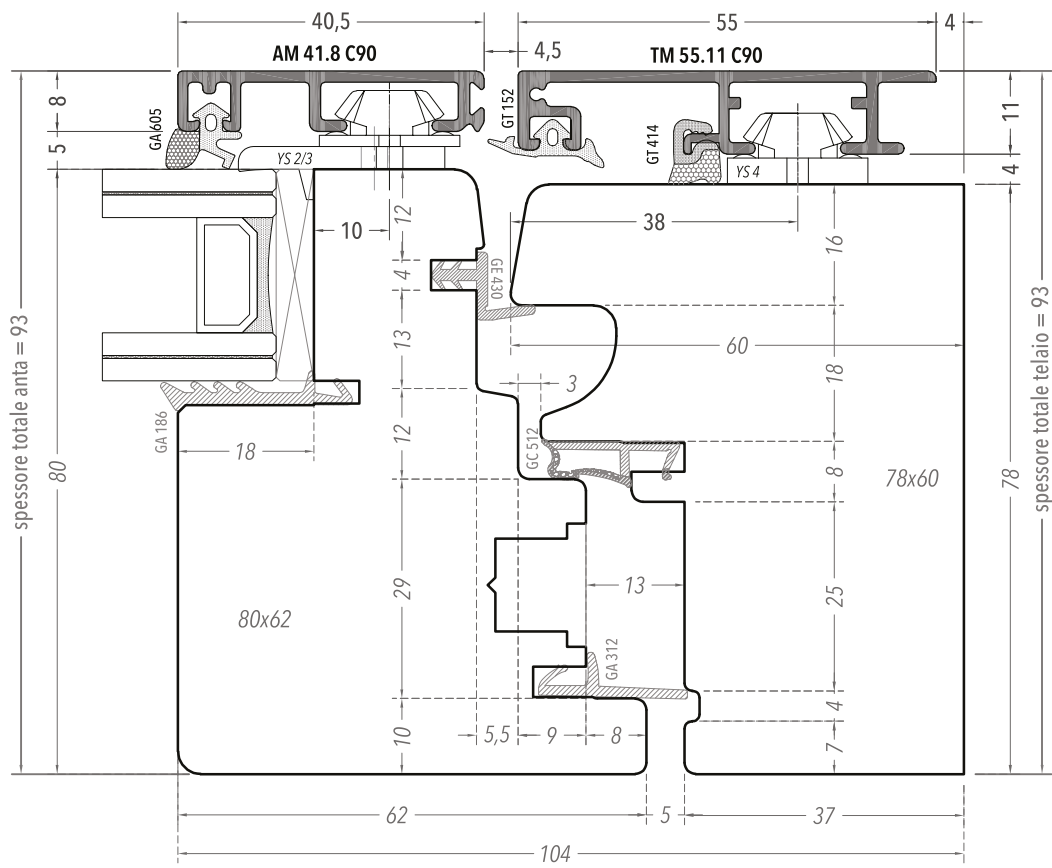

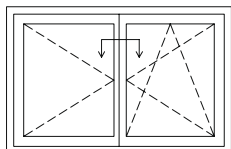

**FINESTRA**

SEZIONE ORIZZONTALE

NODO CENTRALE

SCALA 1:1

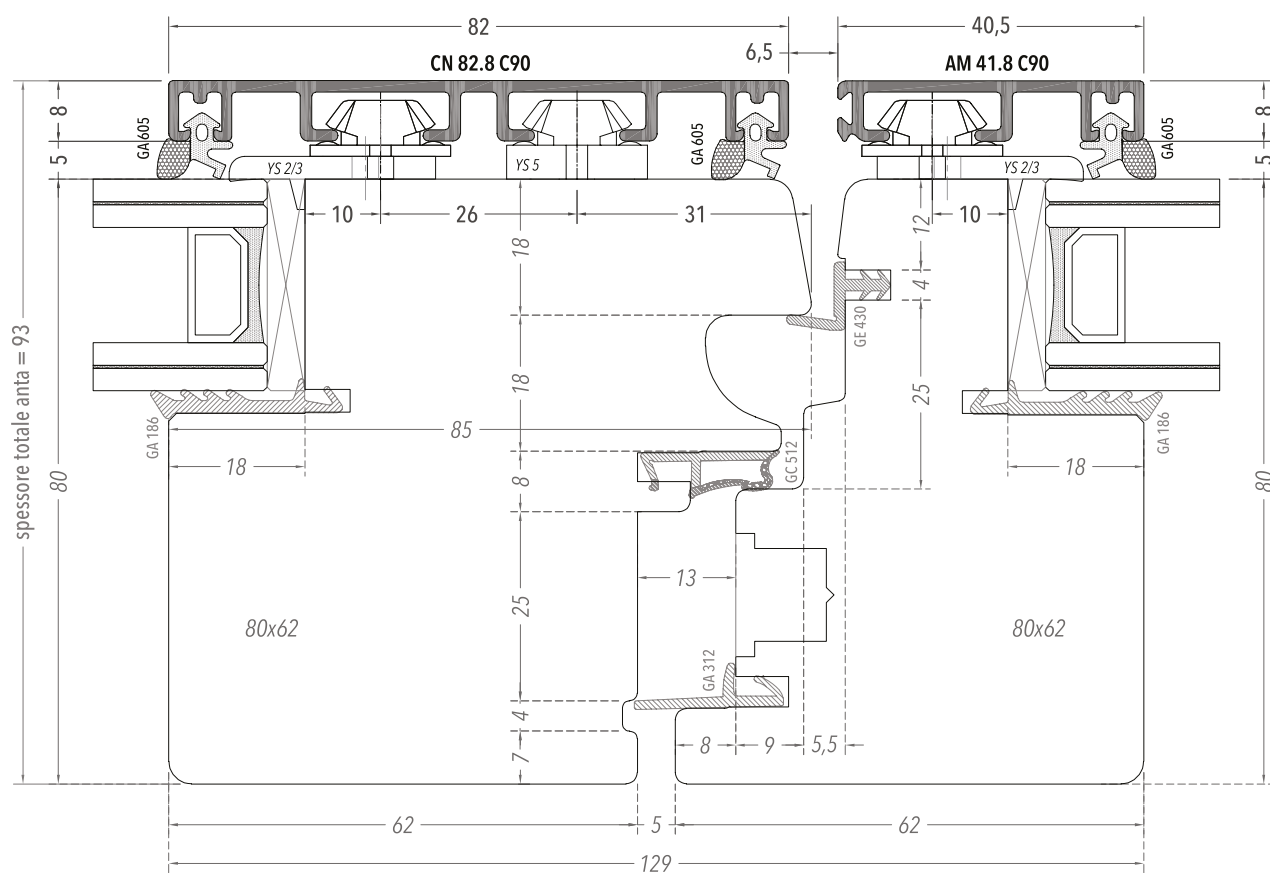

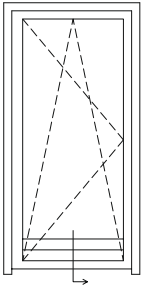

**PORTAFINESTRA**

SEZIONE VERTICALE  
NODO INFERIORE  
SCALA 1:1

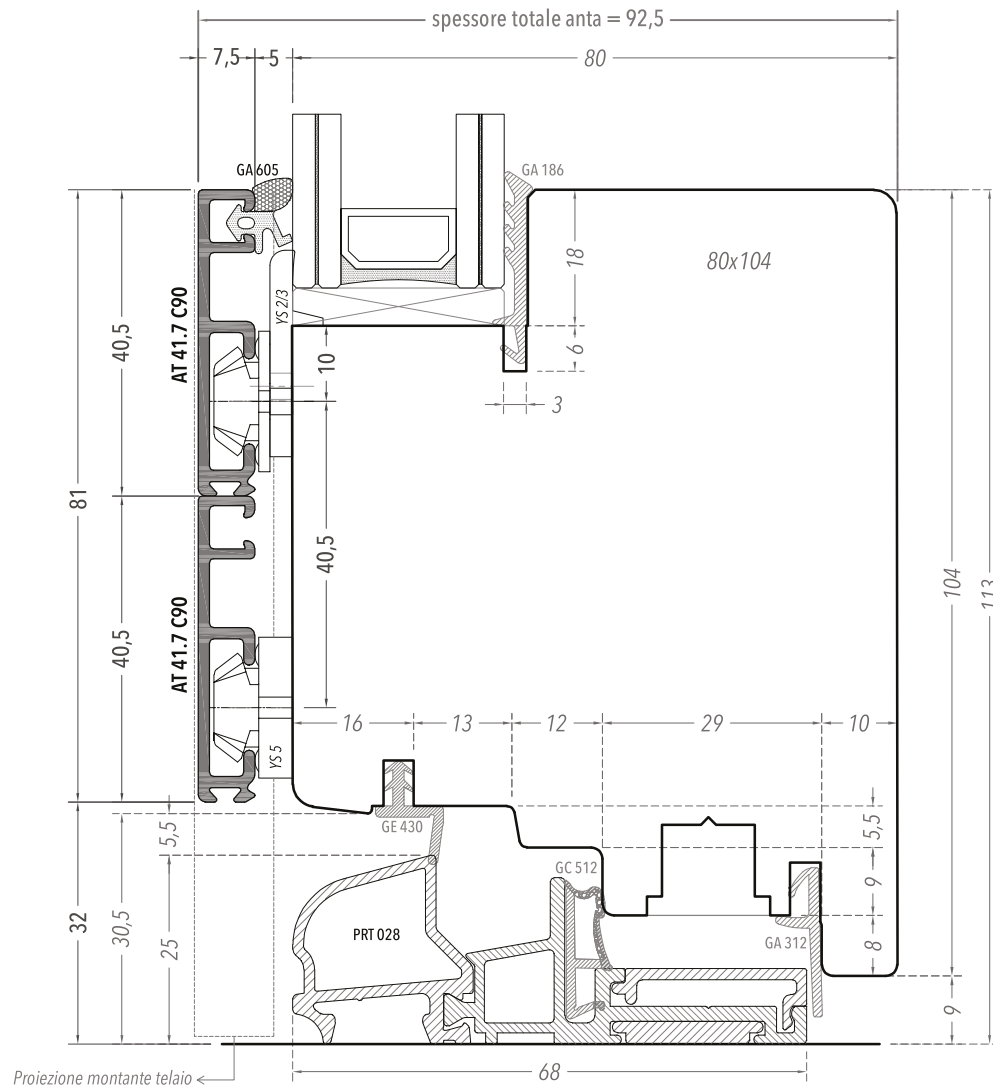





Spessore telaio 74  
Spessore anta 68

# Luce

---

QUADRA

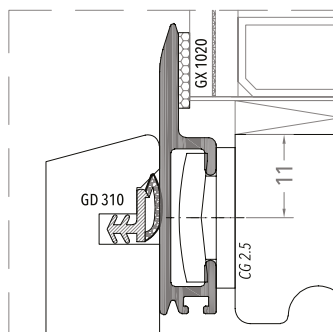
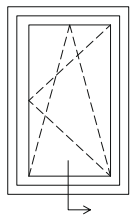

Variante con guarnizione GD 310  
su telaio

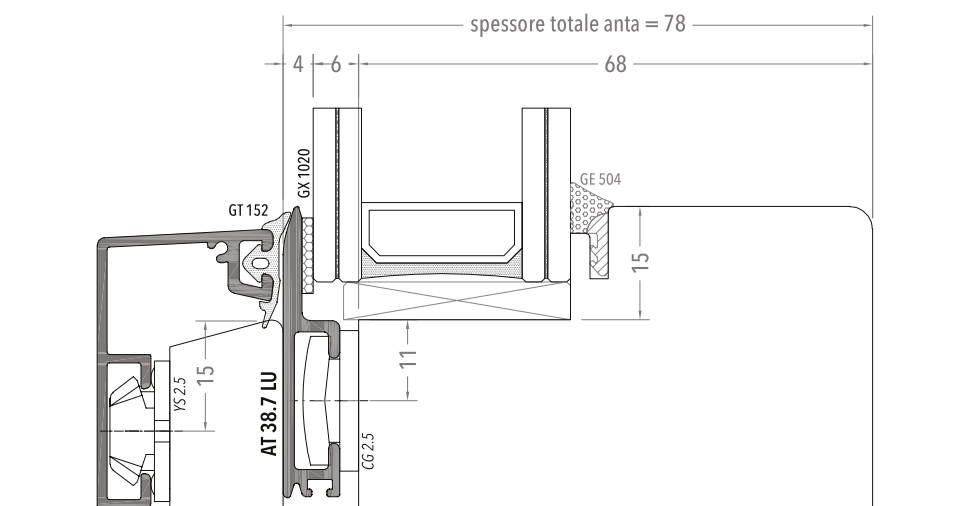

Variante con vetro a sbalzo e profilo anta Linea Plus  
La guarnizione GX 1020 sarà fornita incollata sul profilo.

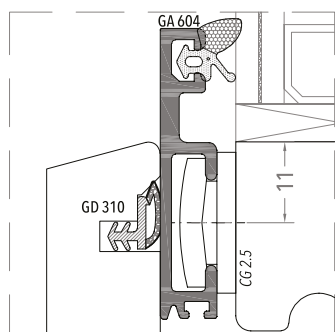

Variante con guarnizione GD 310  
su telaio

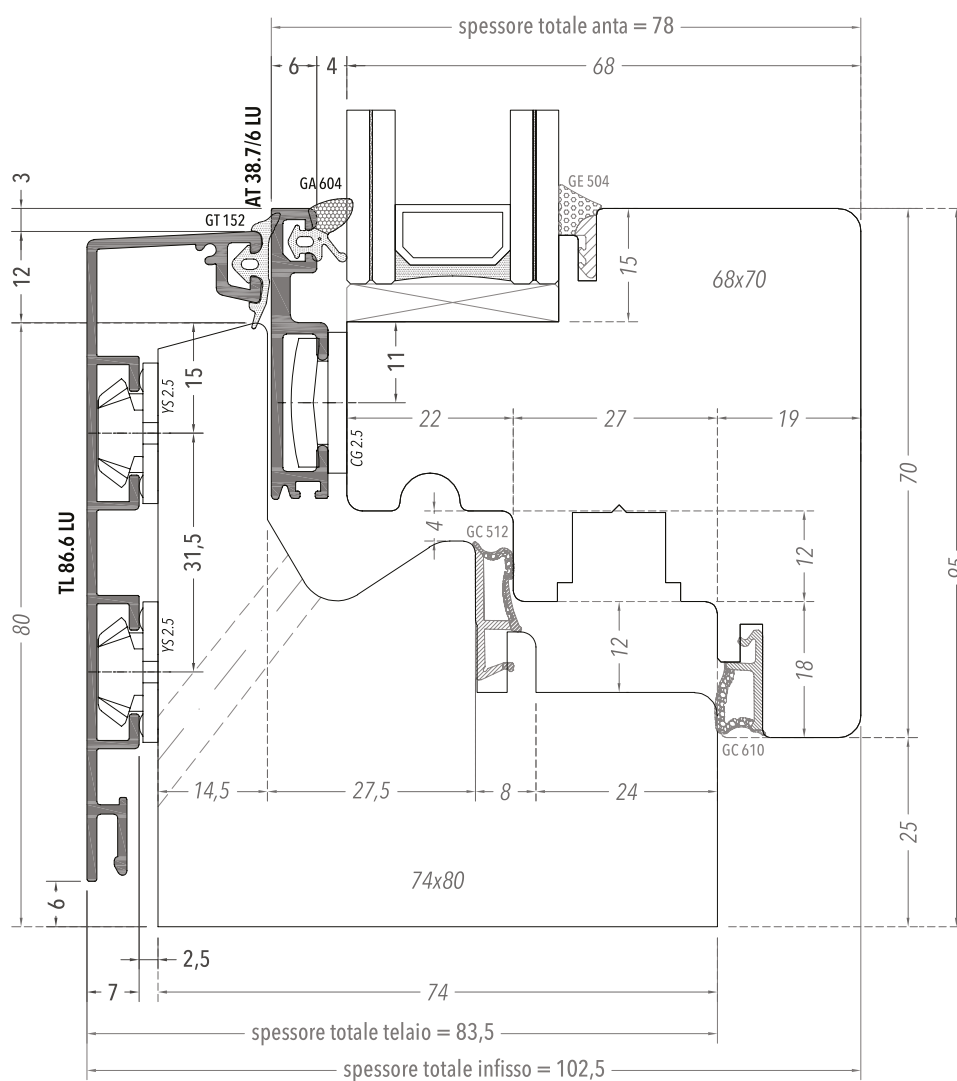



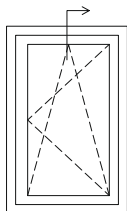

**FINESTRA**

SEZIONE VERTICALE  
NODO SUPERIORE  
SCALA 1:1

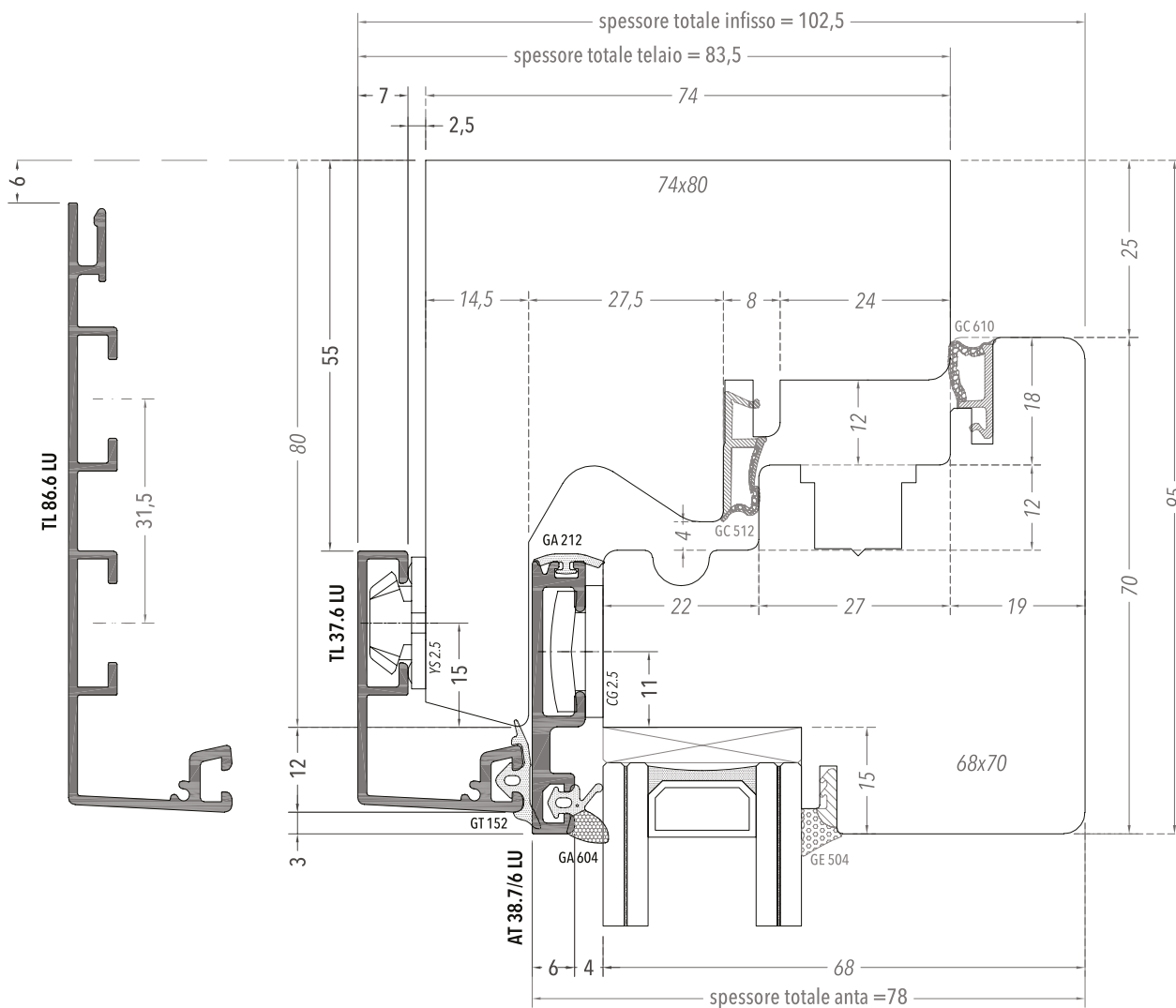

Variante con vetro a sbalzo e profilo anta Linea Plus.  
La guarnizione GX 1020 sarà fornita incollata sul profilo.

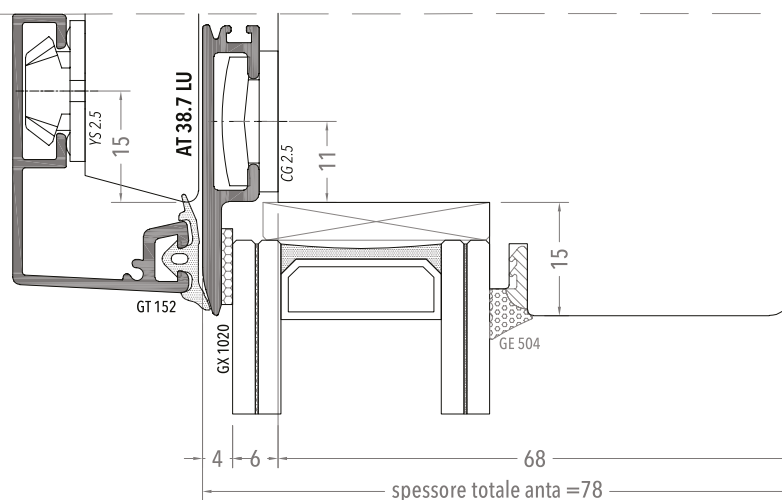

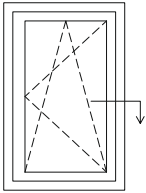

**FINESTRA**

SEZIONE ORIZZONTALE  
NODO LATERALE  
SCALA 1:1

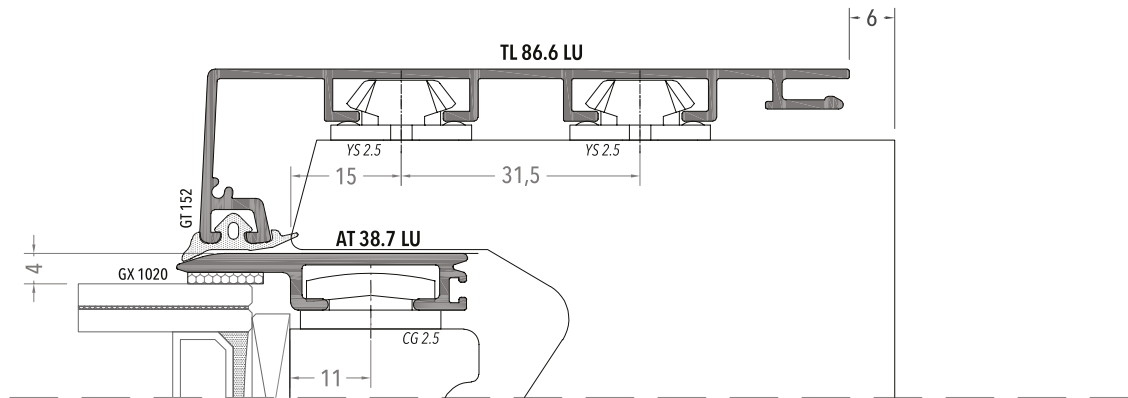

Variante con vetro a sbalzo e profilo anta Linea Plus.  
La guarnizione GX 1020 sarà fornita incollata sul profilo.

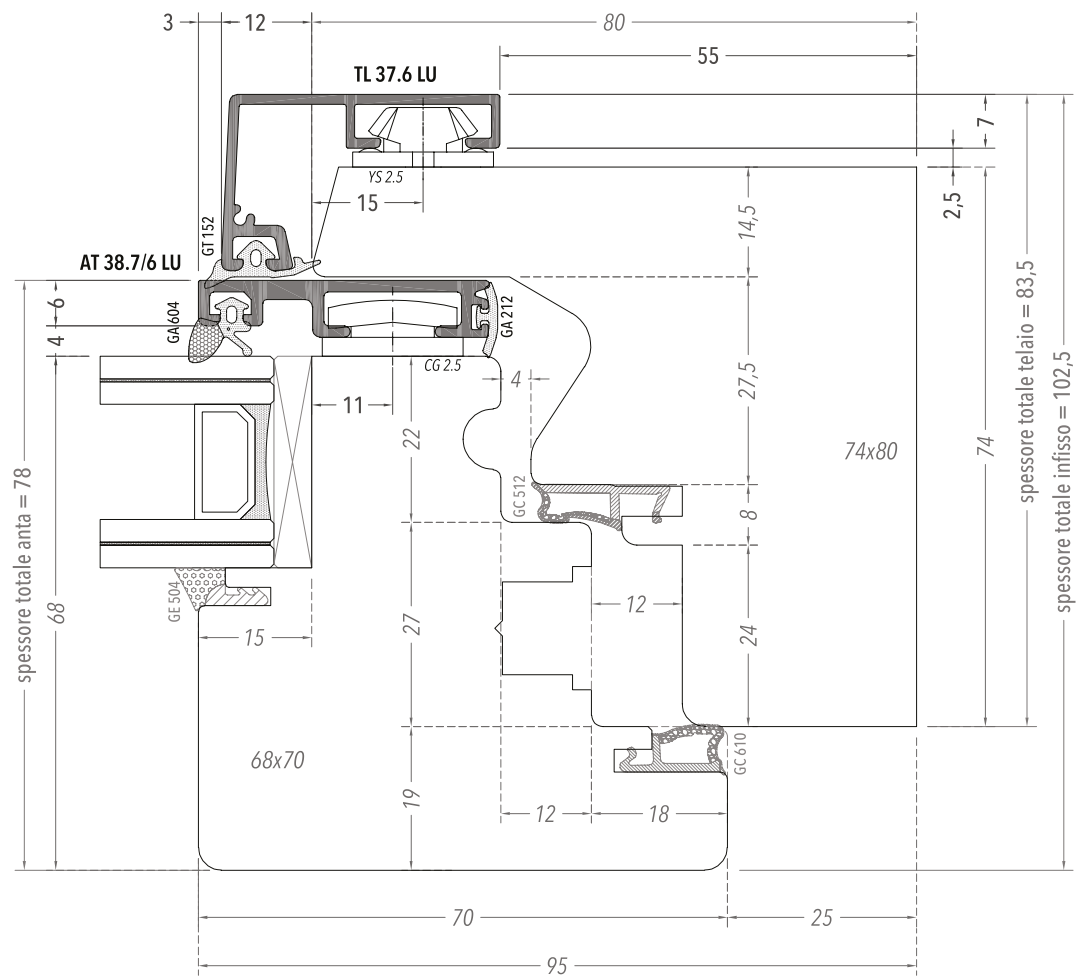

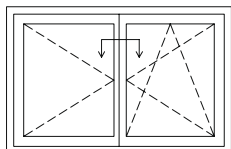

# FINESTRA

SEZIONE ORIZZONTALE  
NODO CENTRALE  
SCALA 1:1

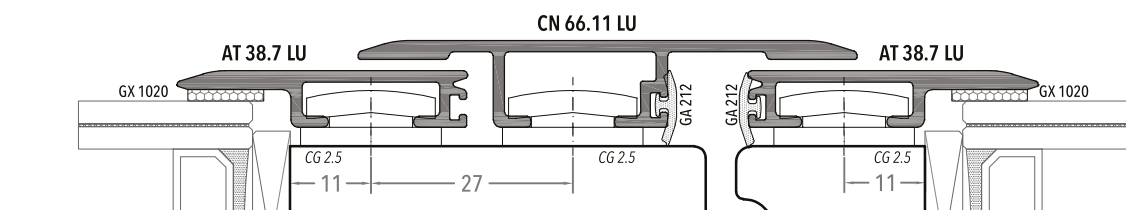

Variante con vetro a sbalzo e profilo anta Linea Plus.  
La guarnizione GX 1020 sarà fornita incollata sul profilo.

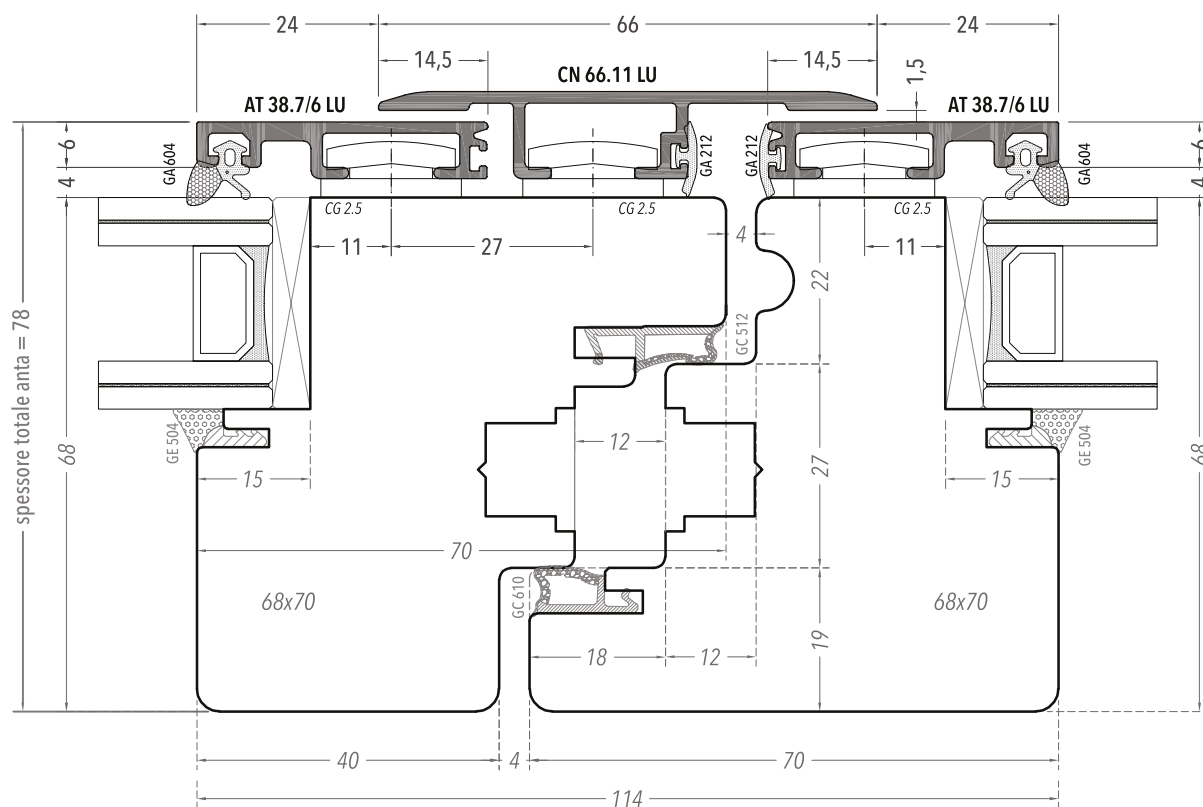

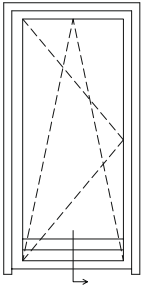

**PORTAFINESTRA**

SEZIONE VERTICALE  
NODO INFERIORE  
SCALA 1:1

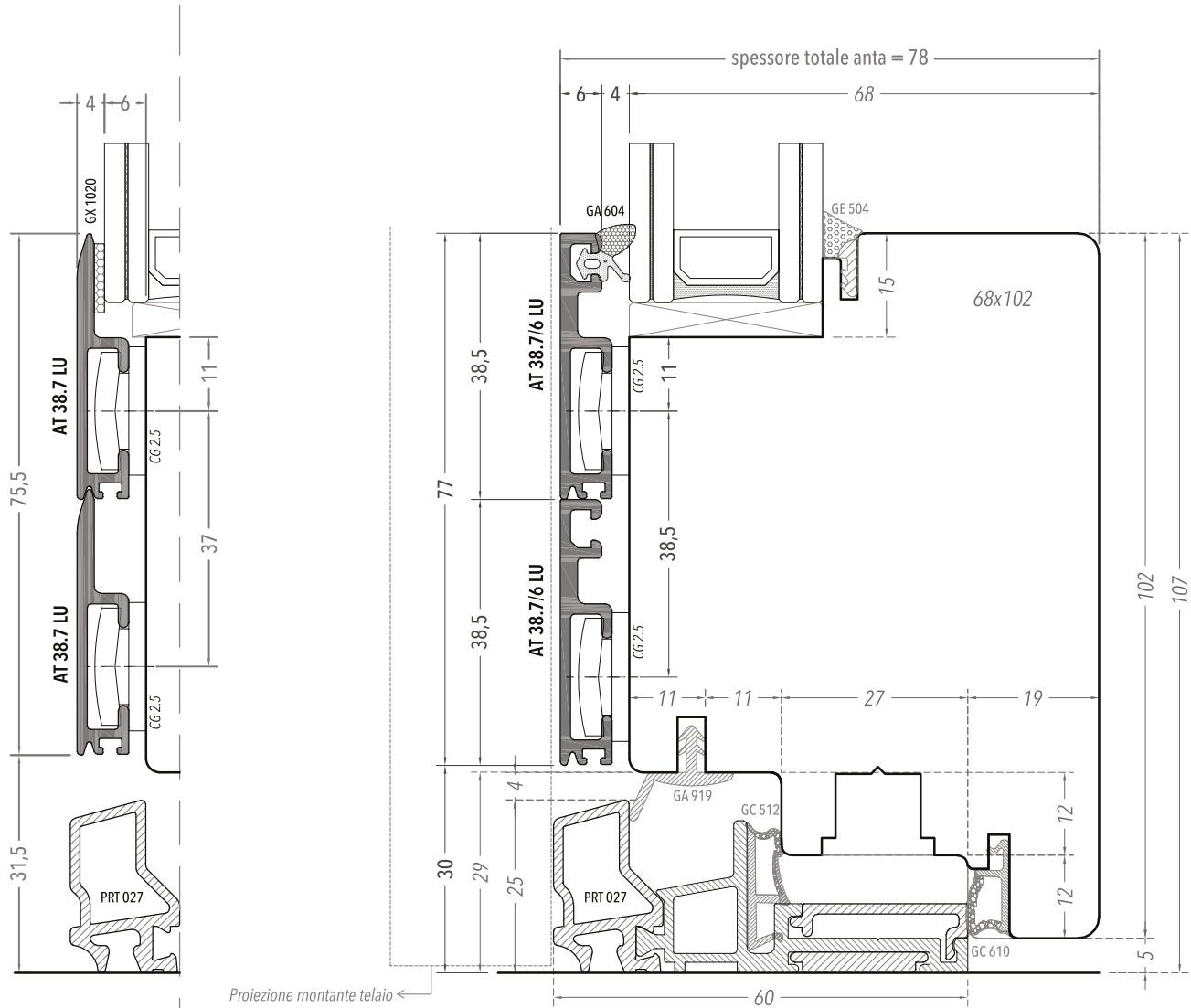

Variante con vetro a sbalzo e profilo anta Linea Plus.  
La guarnizione GX 1020 sarà fornita incollata sul profilo.



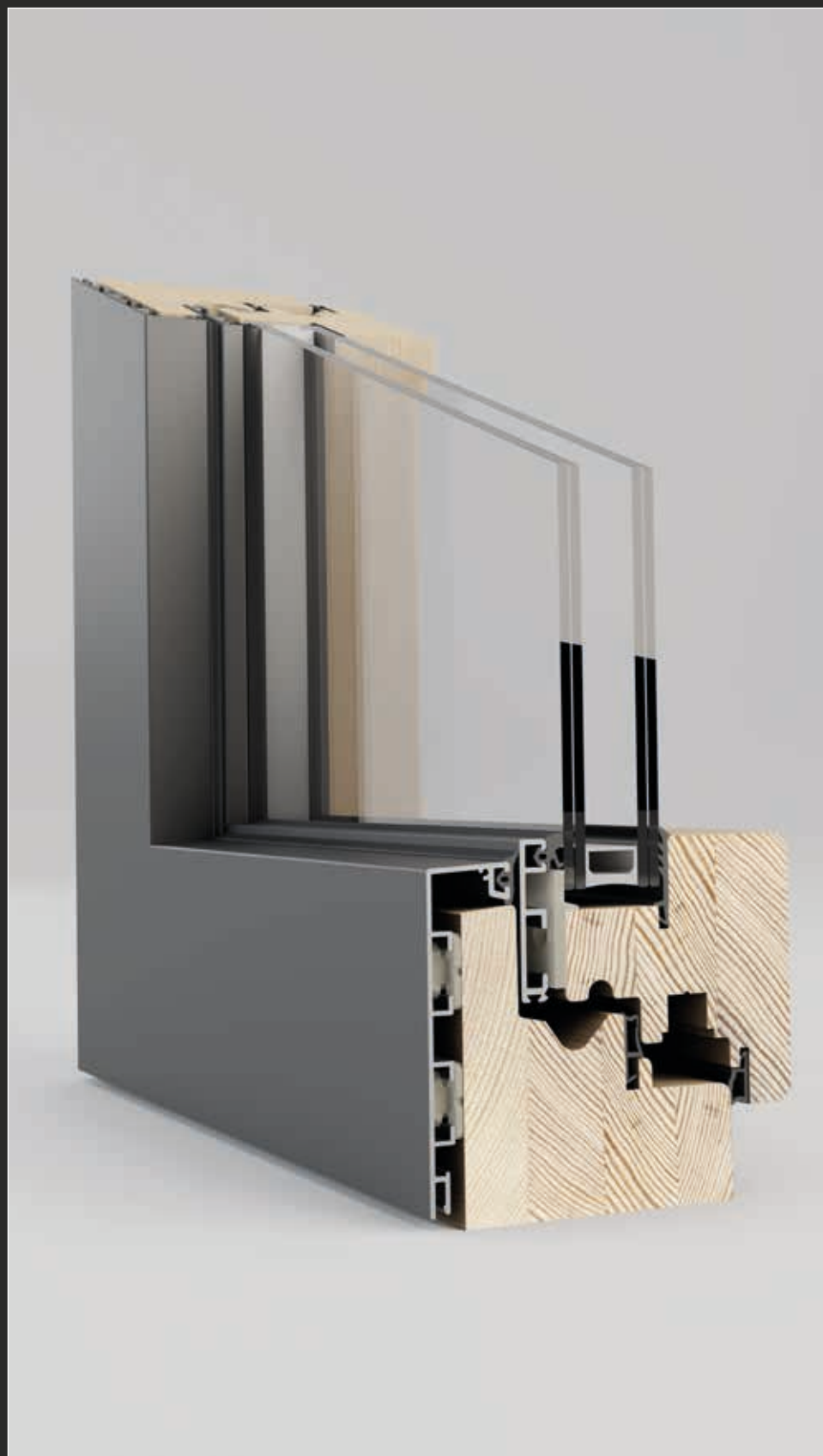

Spessore telaio 78  
Spessore anta 68

# Luce

---

# ALUMFAST

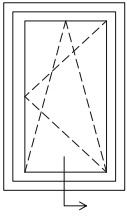

**FINESTRA**

SEZIONE VERTICALE  
NODO INFERIORE  
SCALA 1:1

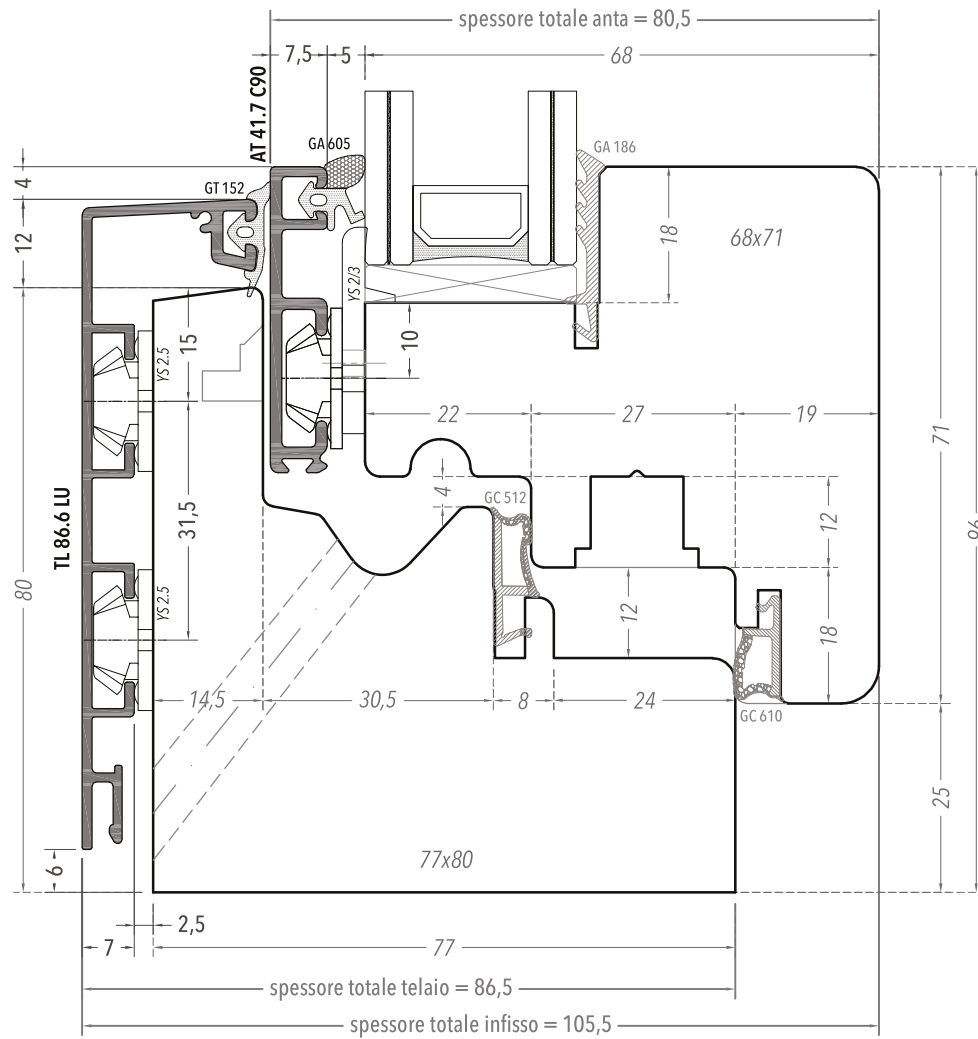



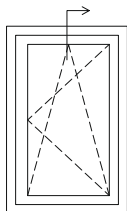

**FINESTRA**  
 SEZIONE VERTICALE  
 NODO SUPERIORE  
 SCALA 1:1

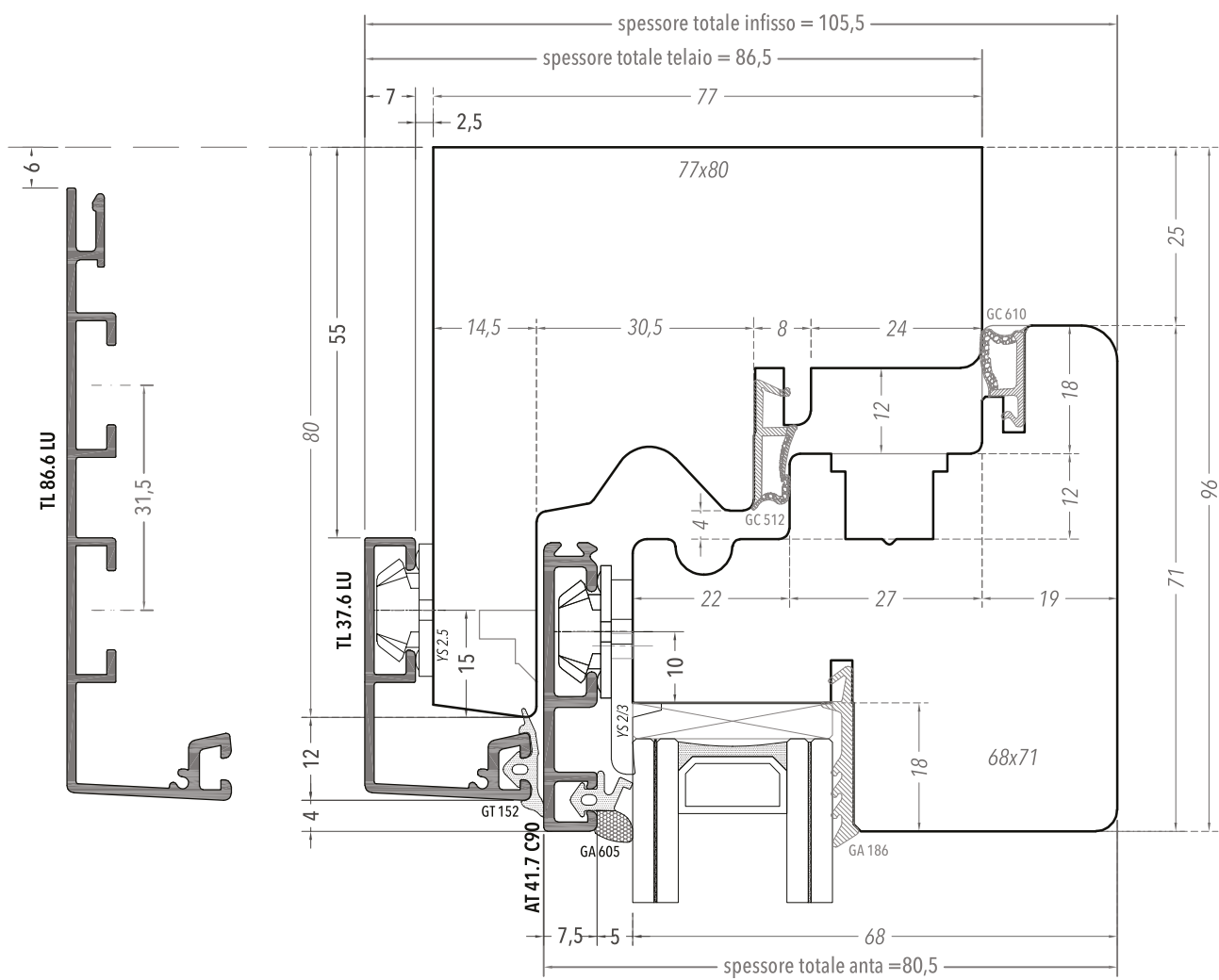

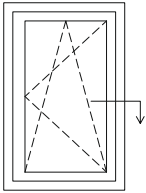

**FINESTRA**

SEZIONE ORIZZONTALE  
NODO LATERALE  
SCALA 1:1

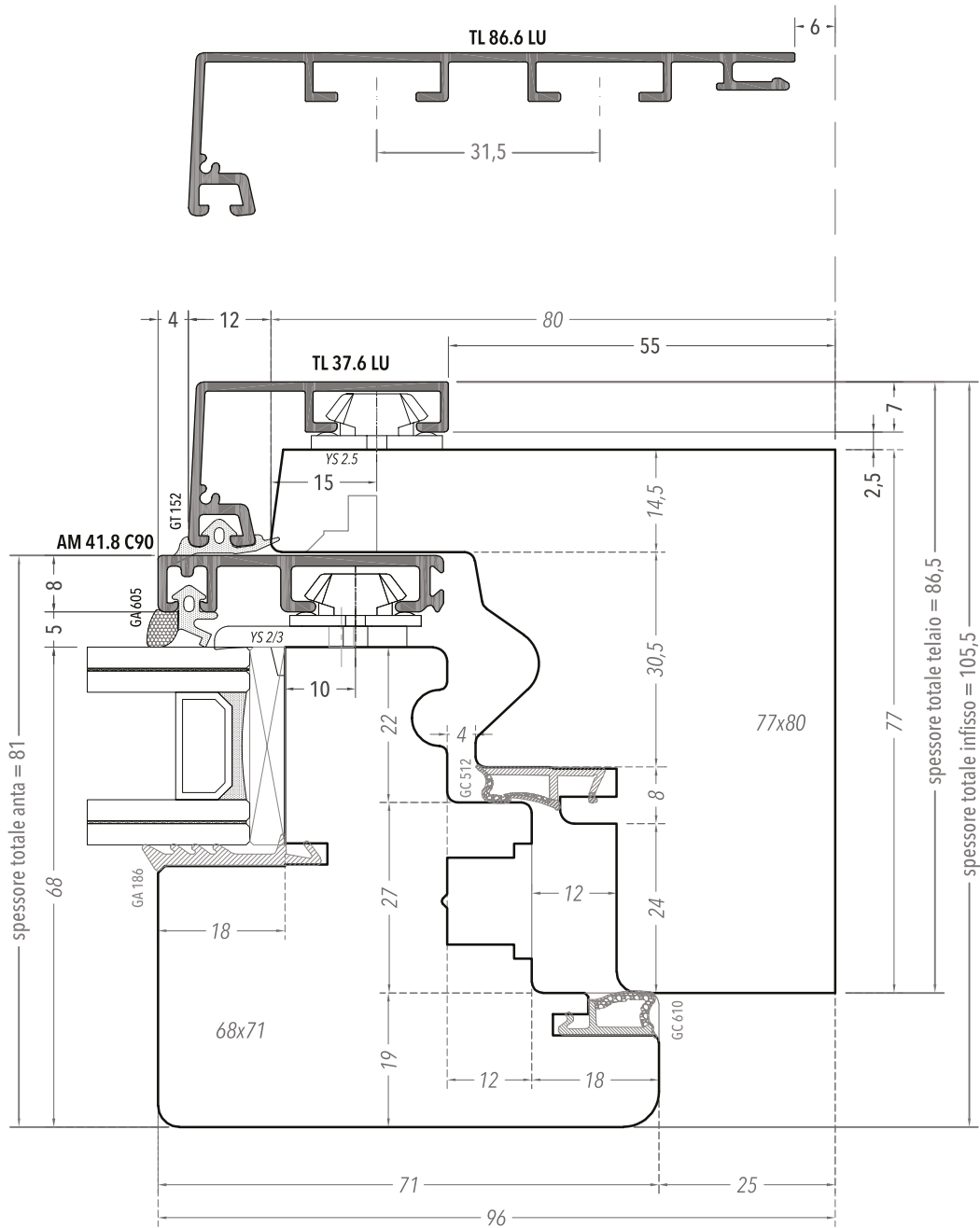

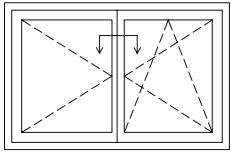

**FINESTRA**  
 SEZIONE ORIZZONTALE  
 NODO CENTRALE  
 SCALA 1:1

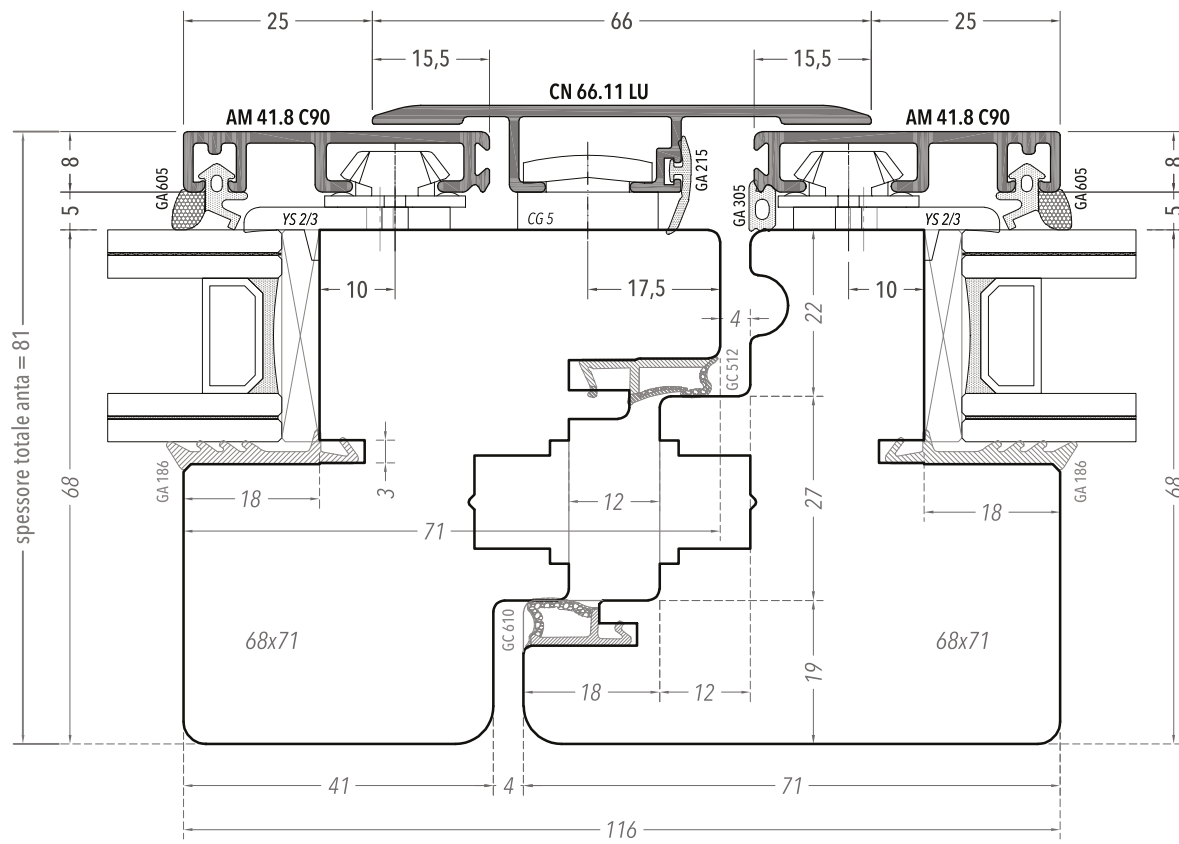

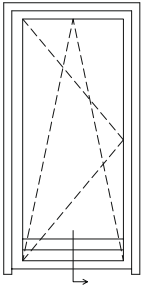

**PORTAFINESTRA**

SEZIONE VERTICALE  
NODO INFERIORE  
SCALA 1:1

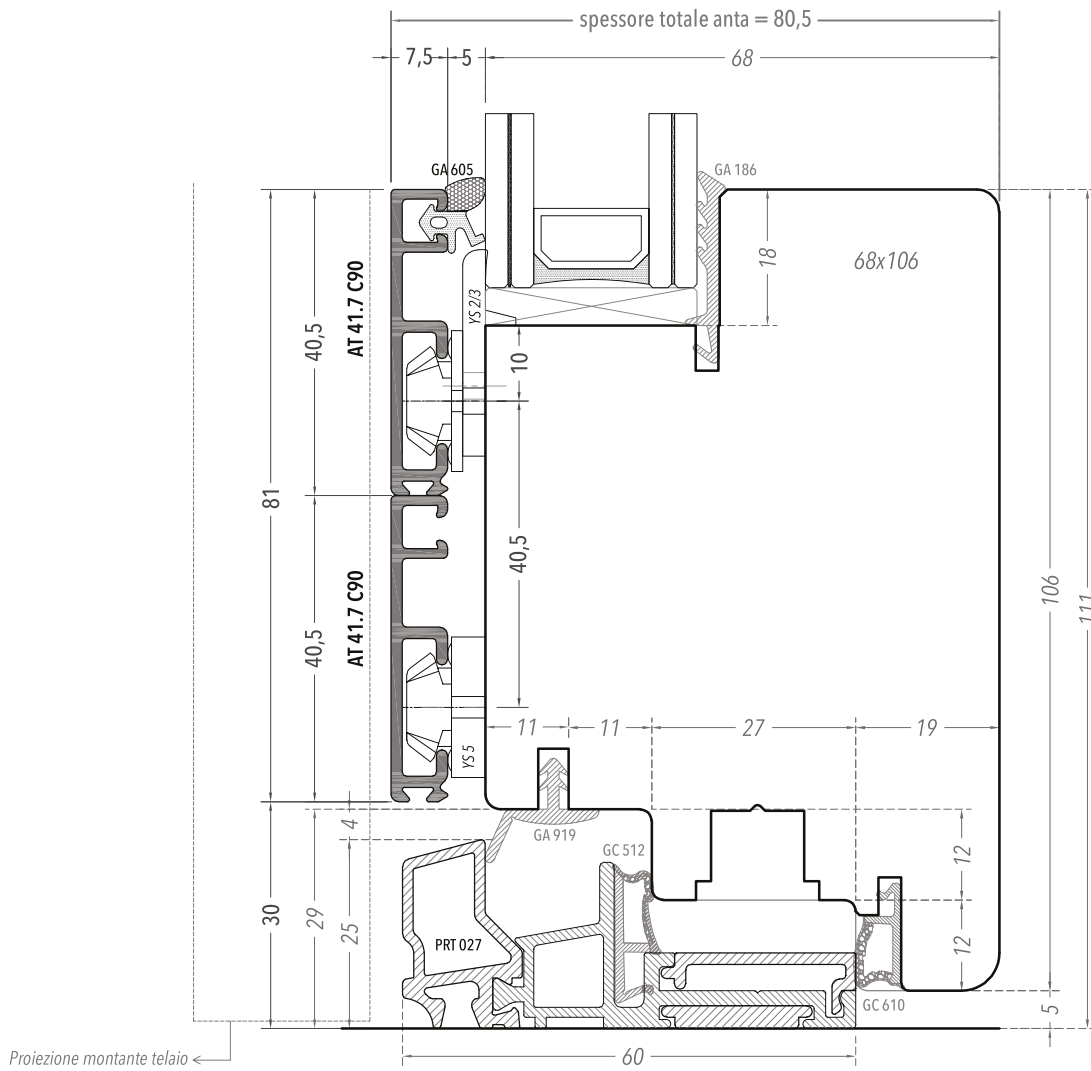

Per tutte le altre combinazioni di profili per gli zoccoli della portafinestra, consulta le pagine introduttive del catalogo.





Spessore telaio 74  
Spessore anta 68

# Luce

---

LEGNO

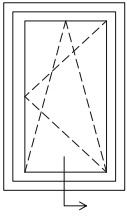

**FINESTRA**

SEZIONE VERTICALE  
 NODO INFERIORE  
 SCALA 1:1

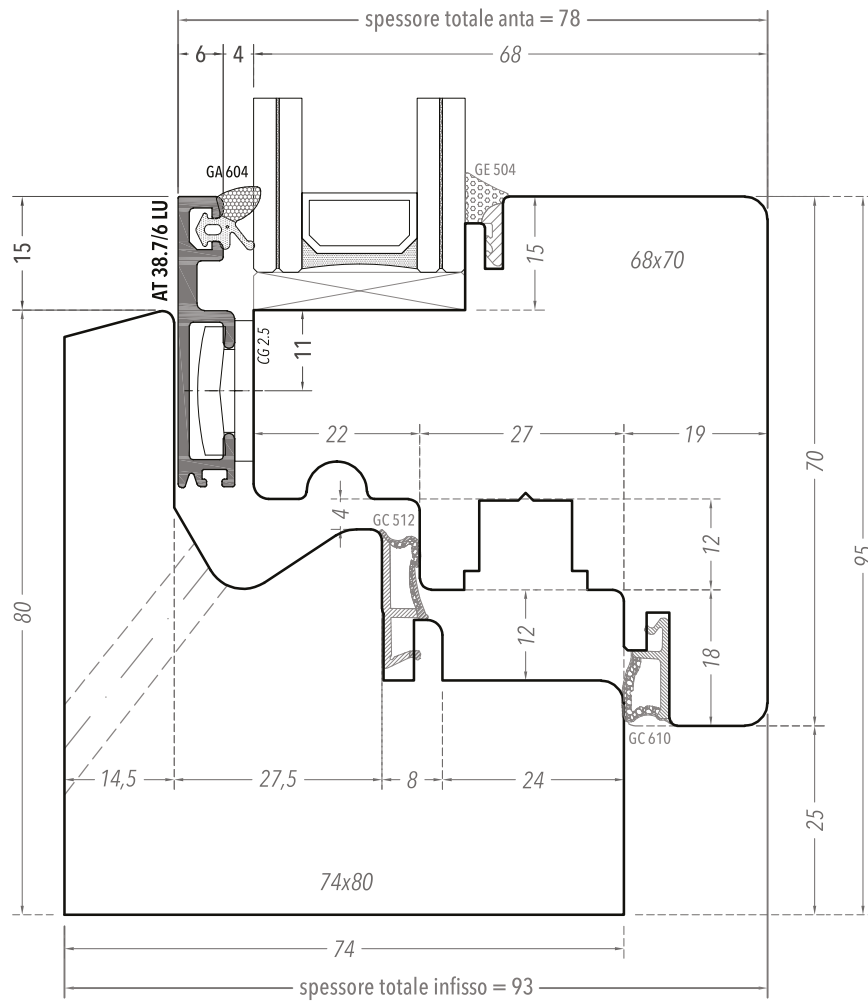



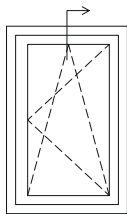

**FINESTRA**  
 SEZIONE VERTICALE  
 NODO SUPERIORE  
 SCALA 1:1

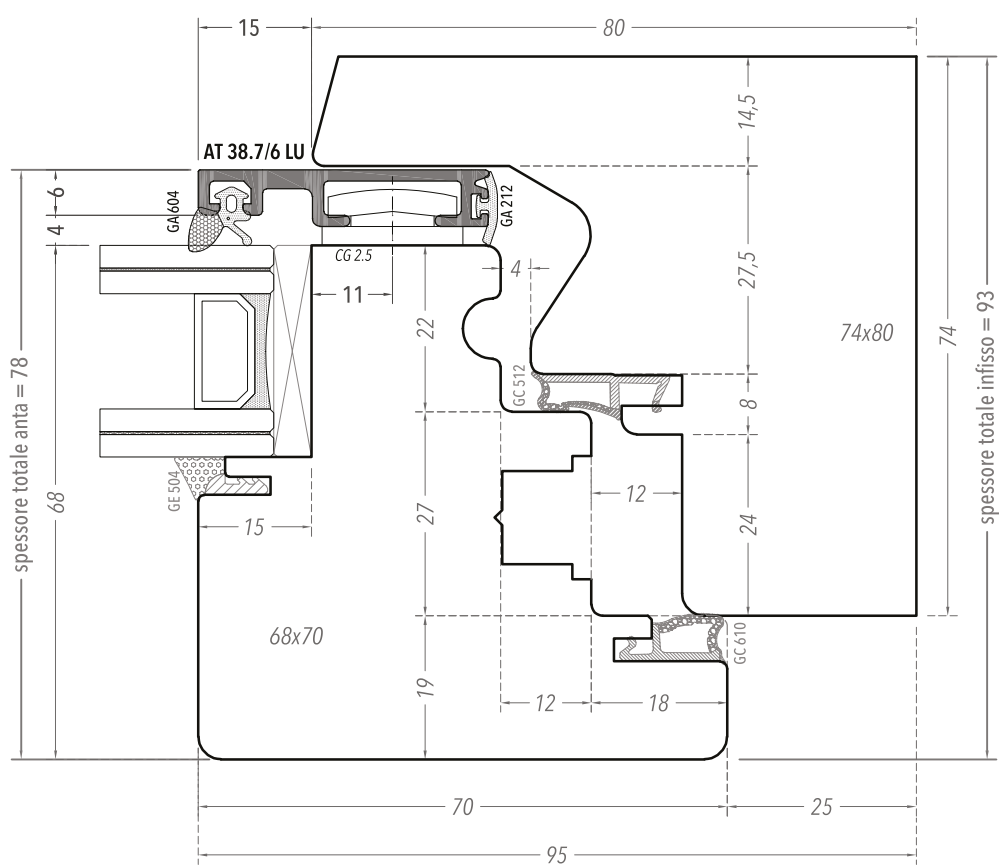

# Bilico

---

Spessore telaio 68  
Spessore anta 68

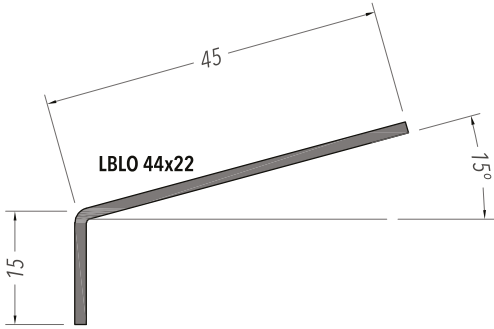
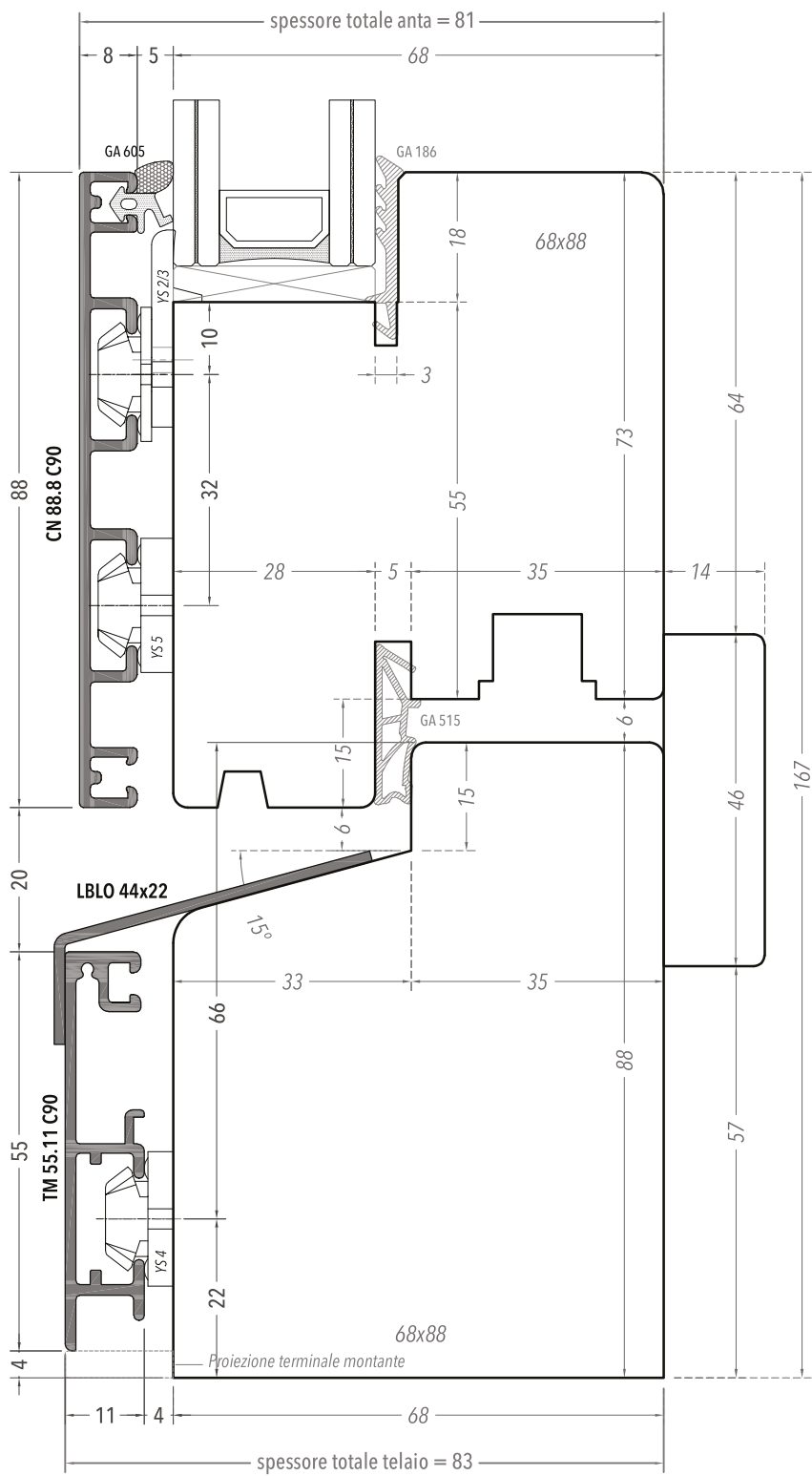
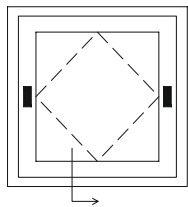

Lamierino pressopiegato  
spessore 1,5 mm

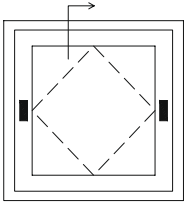

**BILICO**  
 SEZIONE VERTICALE  
 NODO SUPERIORE  
 SCALA 1:1

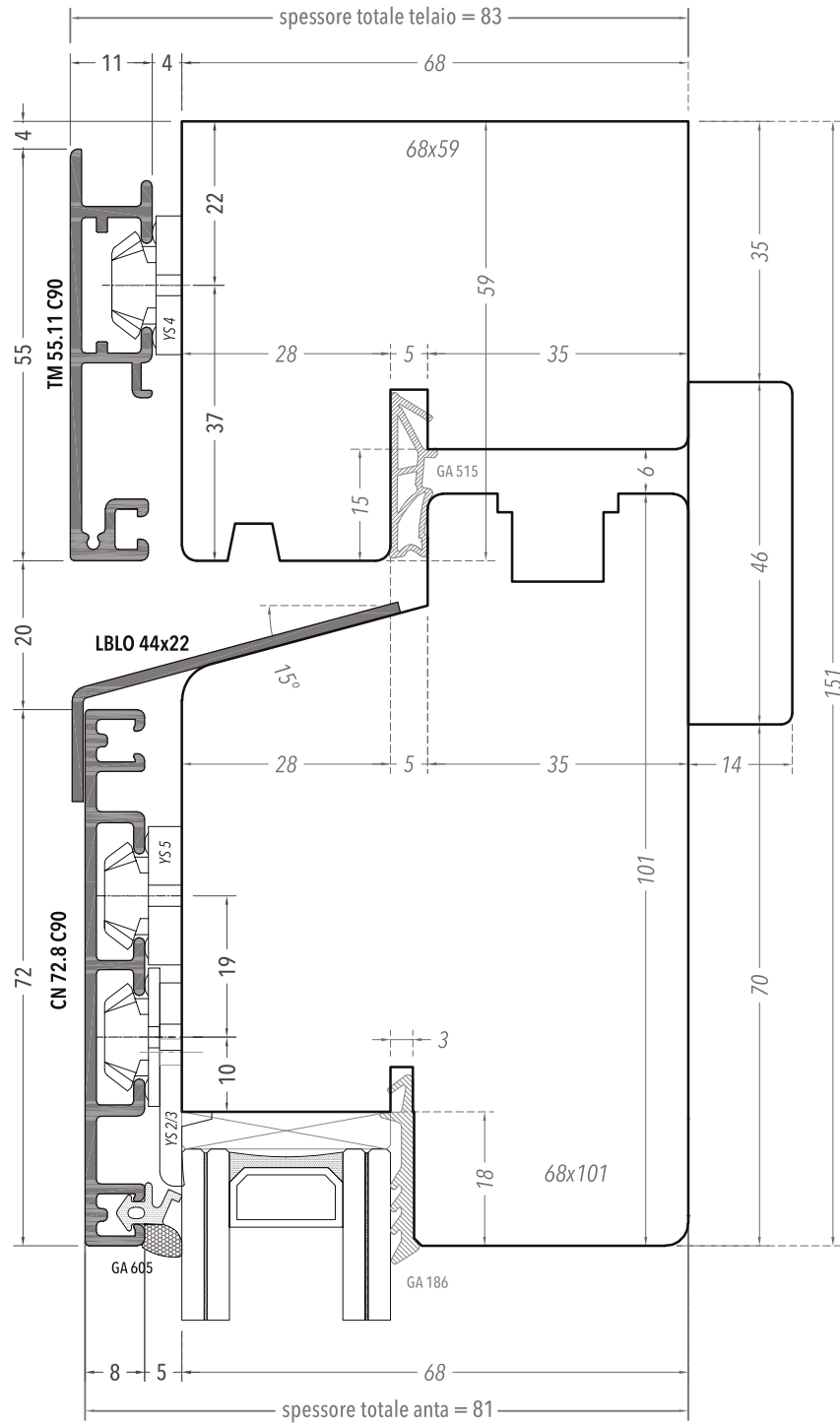

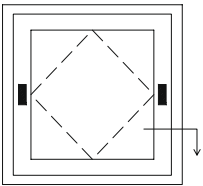

**BILICO**

SEZIONE ORIZZONTALE SOTTO LE CERNIERE  
 NODO LATERALE  
 SCALA 1:1

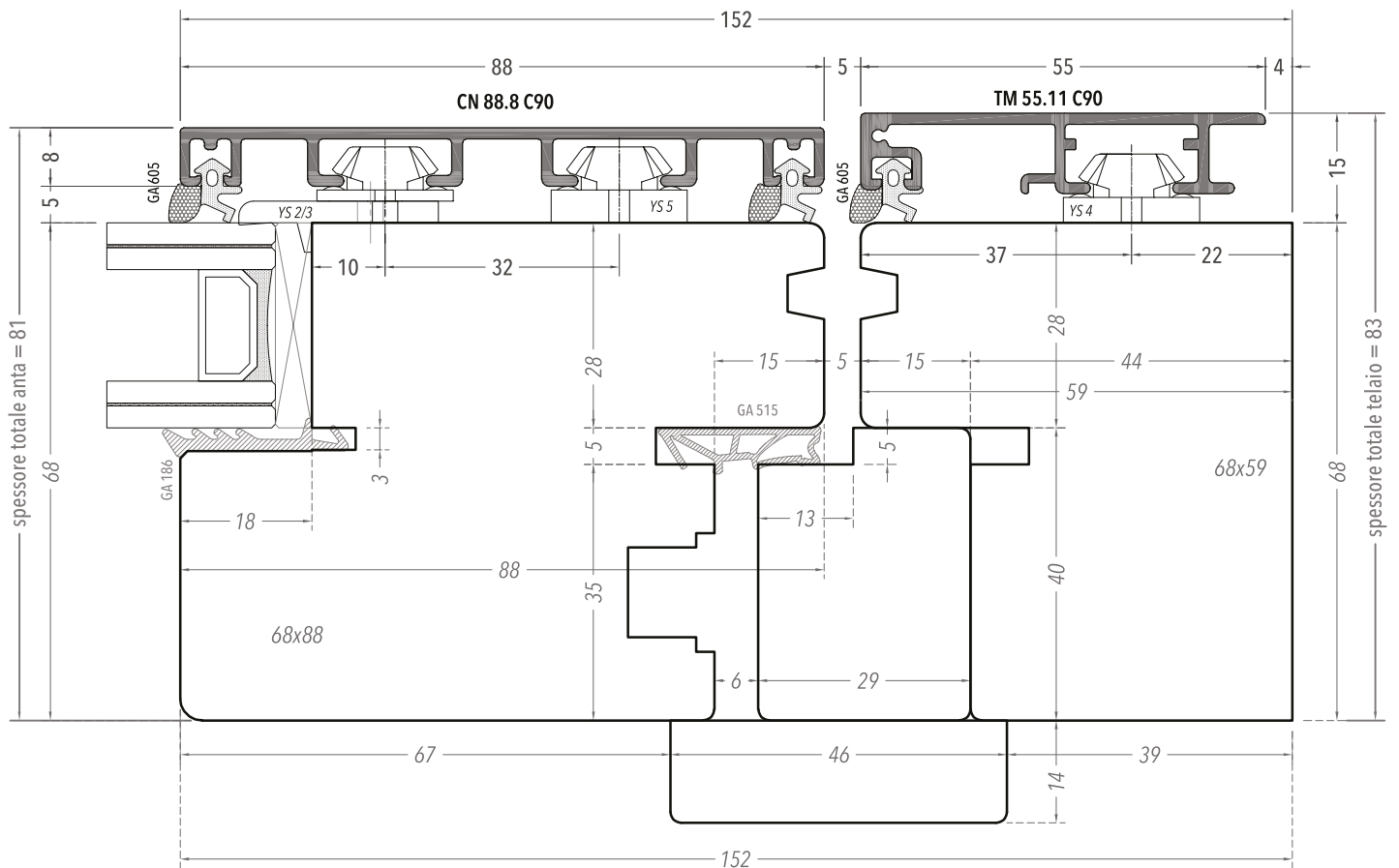

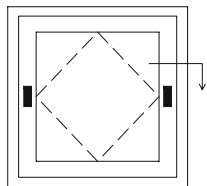

**BILICO**

SEZIONE ORIZZONTALE SOPRA LE CERNIERE  
 NODO LATERALE  
 SCALA 1:1

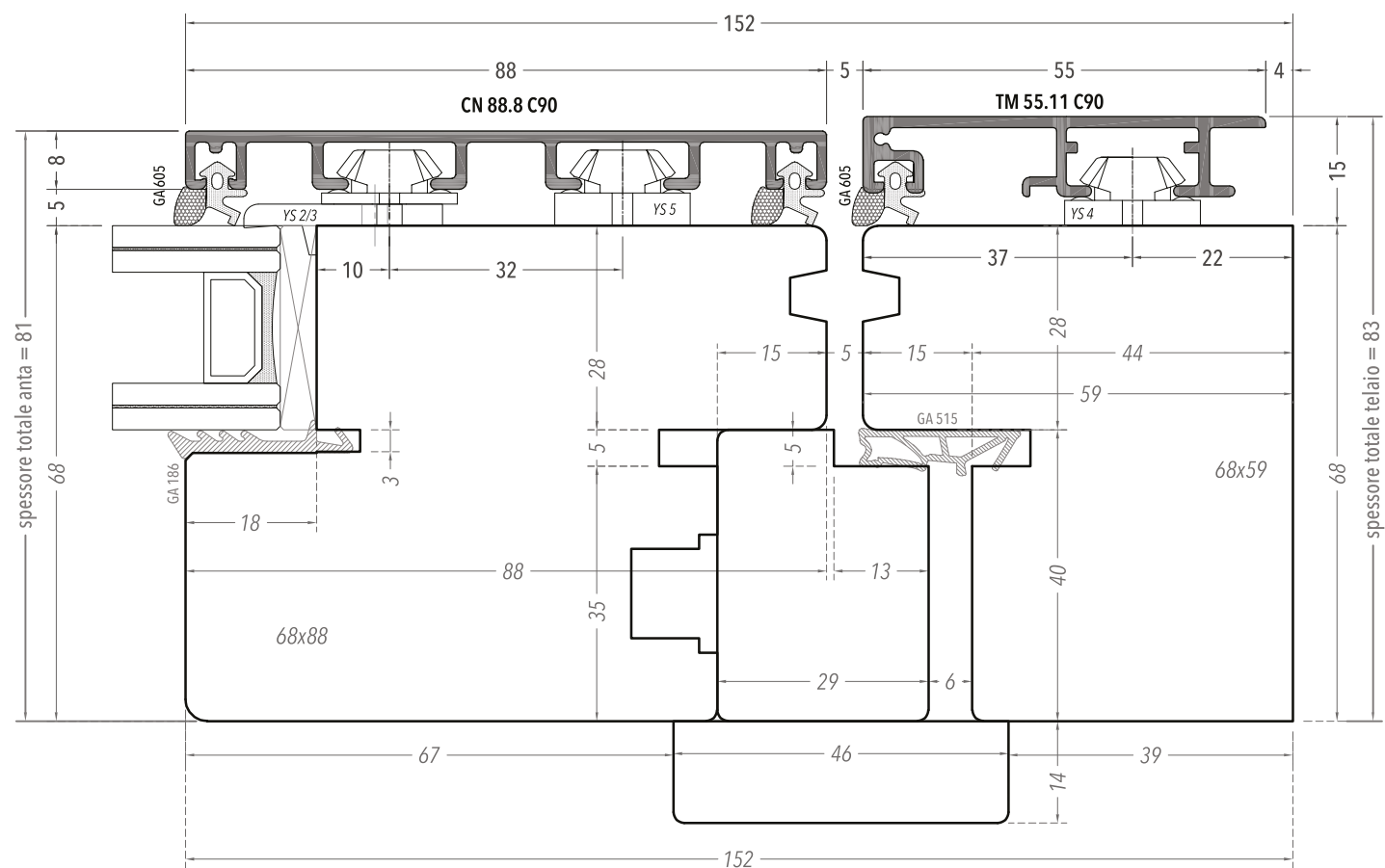



# Porte ad apertura esterna

---

Spessore telaio 68  
Spessore anta 68



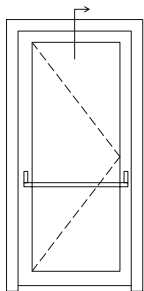

**PORTA AD APERTURA ESTERNA**

SEZIONE VERTICALE  
NODO SUPERIORE  
SCALA 1:1

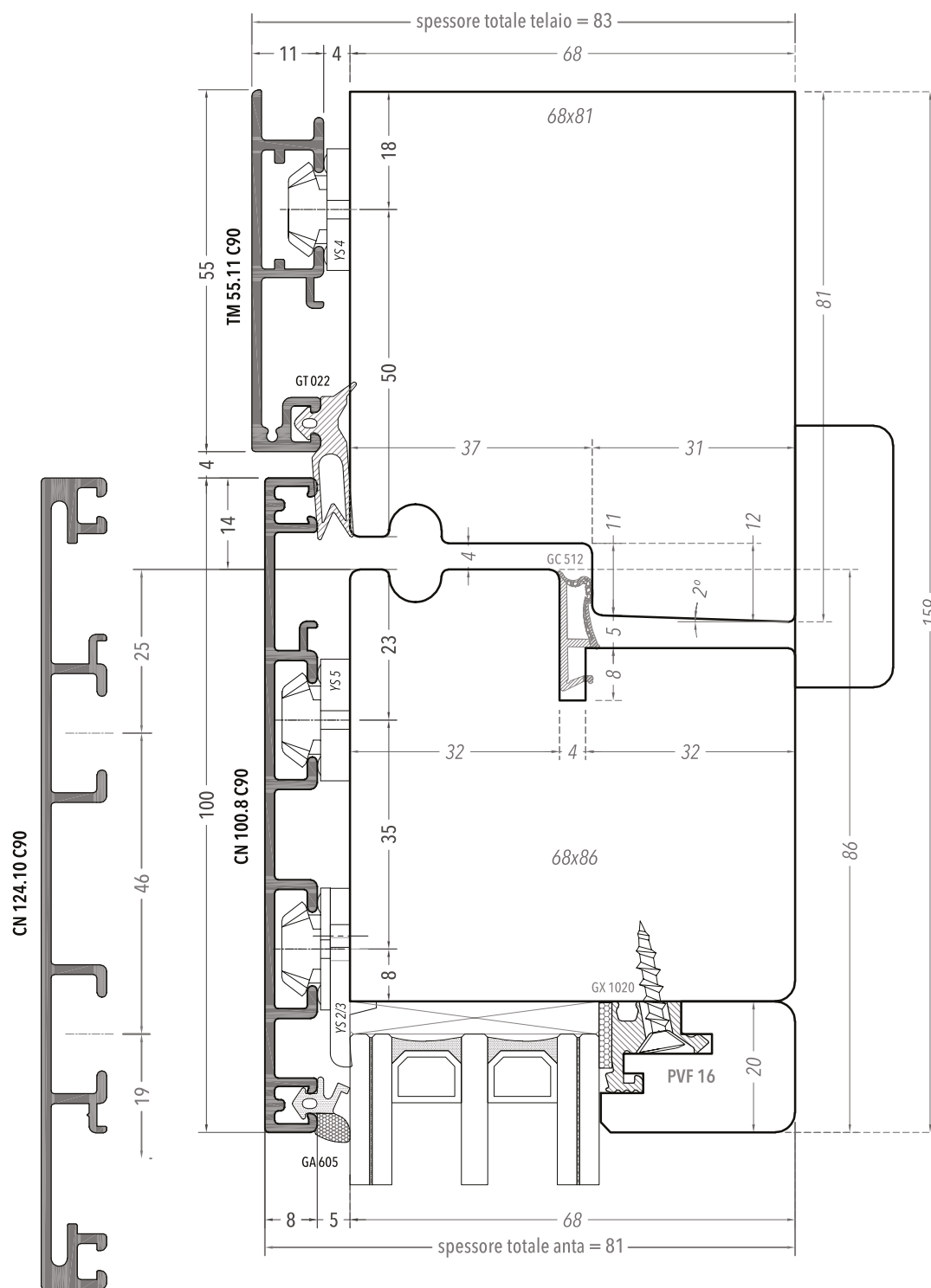

Variante con profilo  
CN 124.10 C90 e anta  
in legno da 110 mm

Profili anta forniti senza terminali.

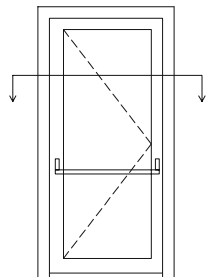

**PORTA AD APERTURA ESTERNA**

SEZIONE ORIZZONTALE  
 NODO LATERALE  
 SCALA 1:1

Variante con profilo CN 124.10 C90  
 e anta in legno da 110 mm

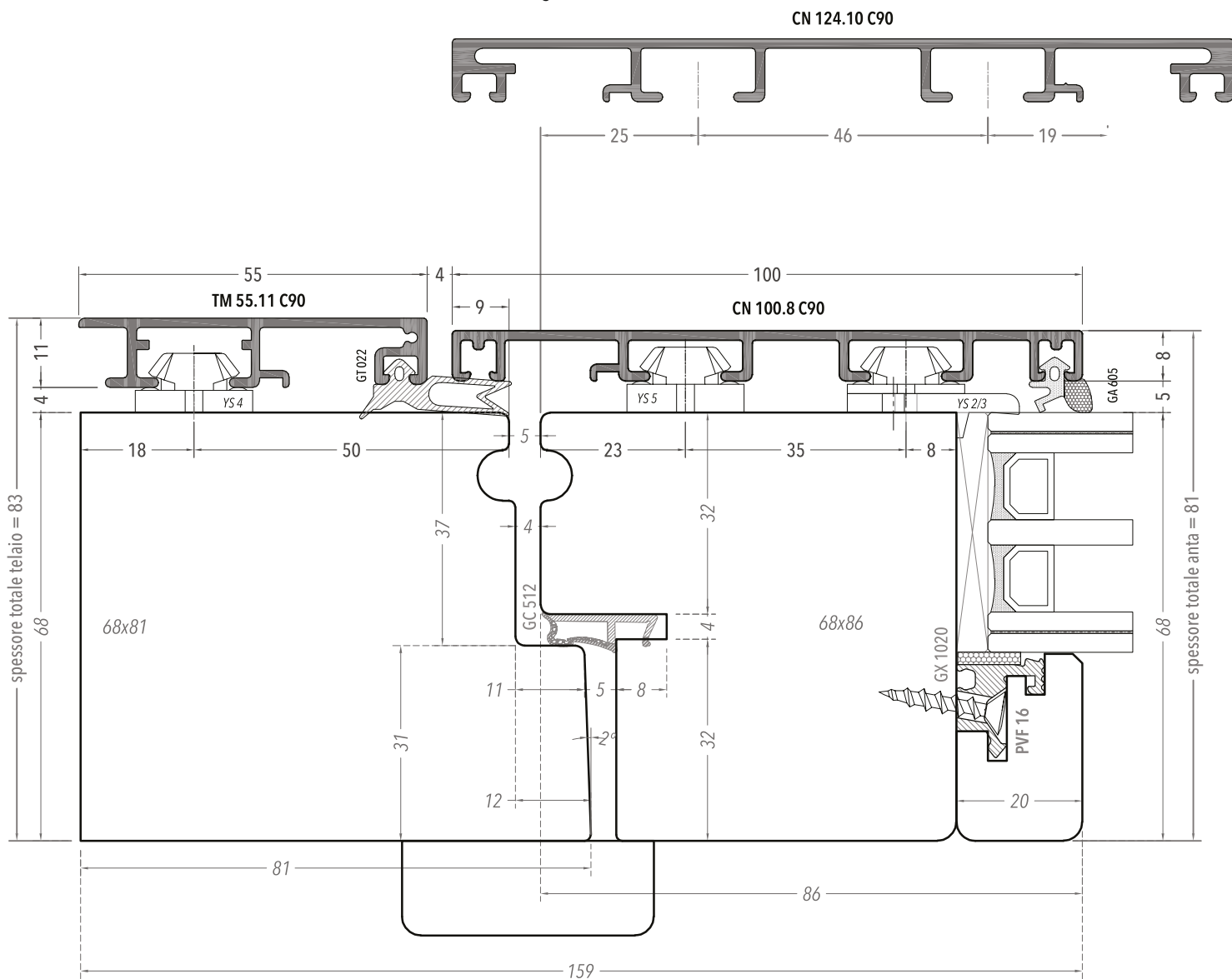

Profili anta forniti senza terminali.

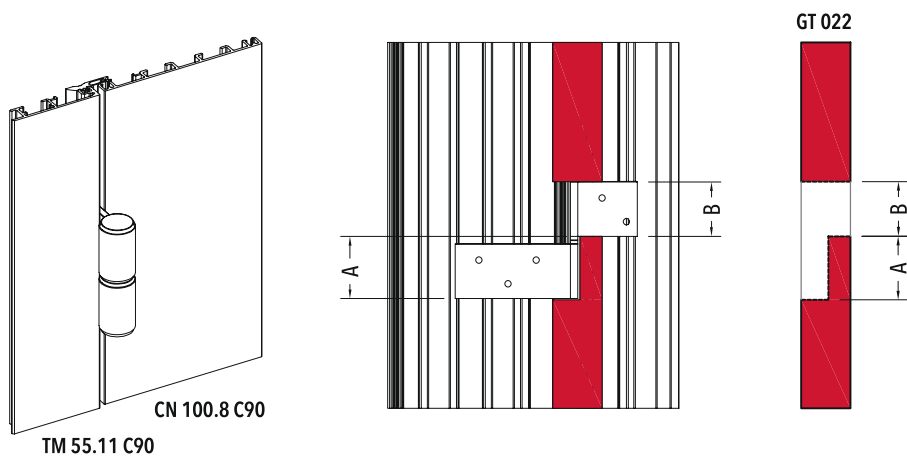

1. La guarnizione GT 022, nel lato cerniera, deve essere interrotta per un'altezza "B" corrispondente al ramo della cerniera dal lato del telaio.
2. Per tutta l'altezza dell'interruzione, si esegua una siliconatura del profilo in alluminio TM 55.11 C90 in prossimità del porta-guarnizione.
3. Nell'altezza "A", rimuovere l'ala della guarnizione in corrispondenza del ramo lato anta della cerniera. La parte rimanente garantisce tenuta all'acqua senza ulteriore siliconatura.

Variante con profilo CN 124.10 C90 e anta in legno da 110 mm

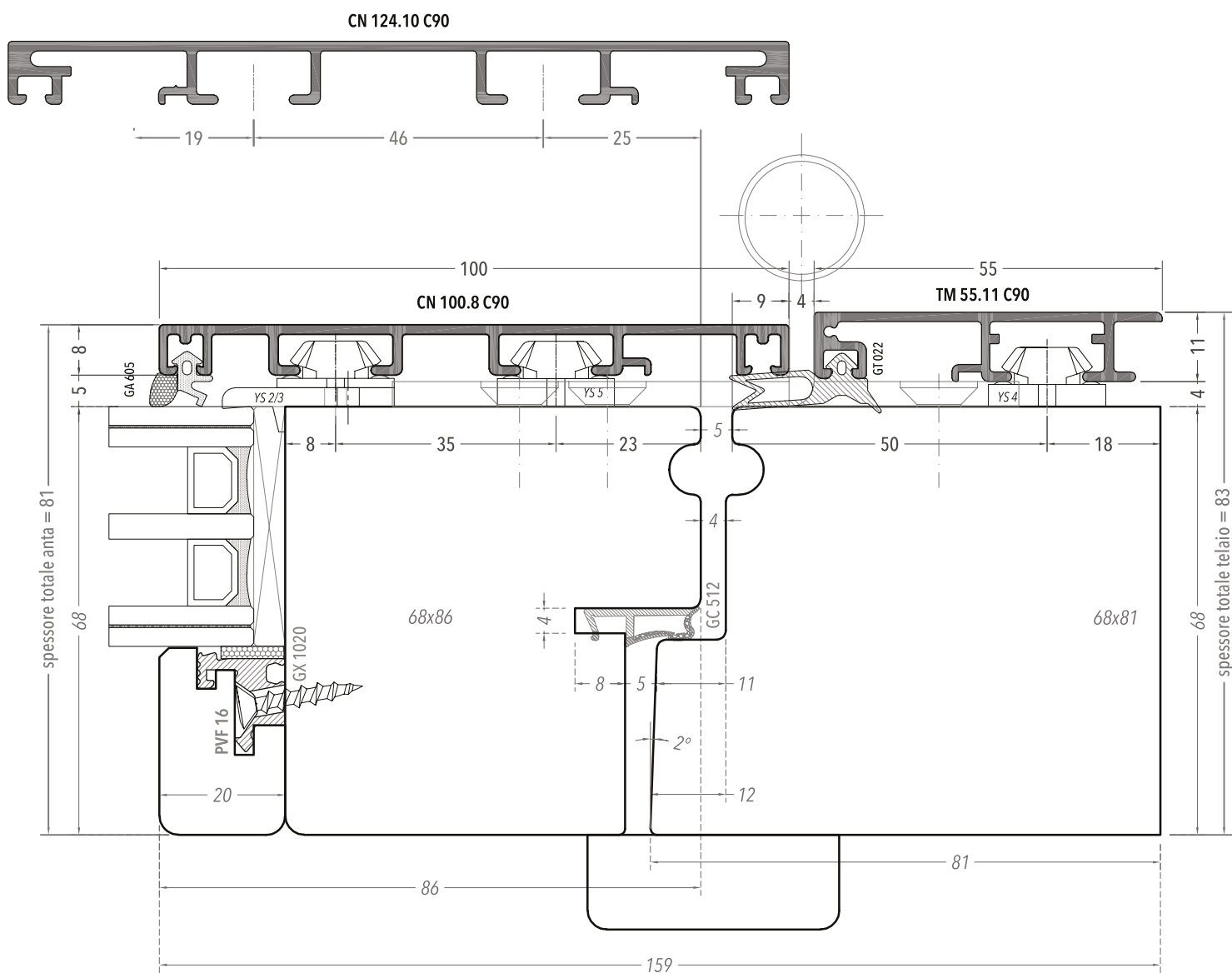

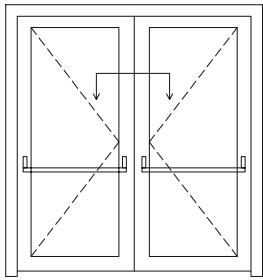

**PORTA AD APERTURA ESTERNA**

SEZIONE ORIZZONTALE  
NODO CENTRALE  
SCALA 1:1

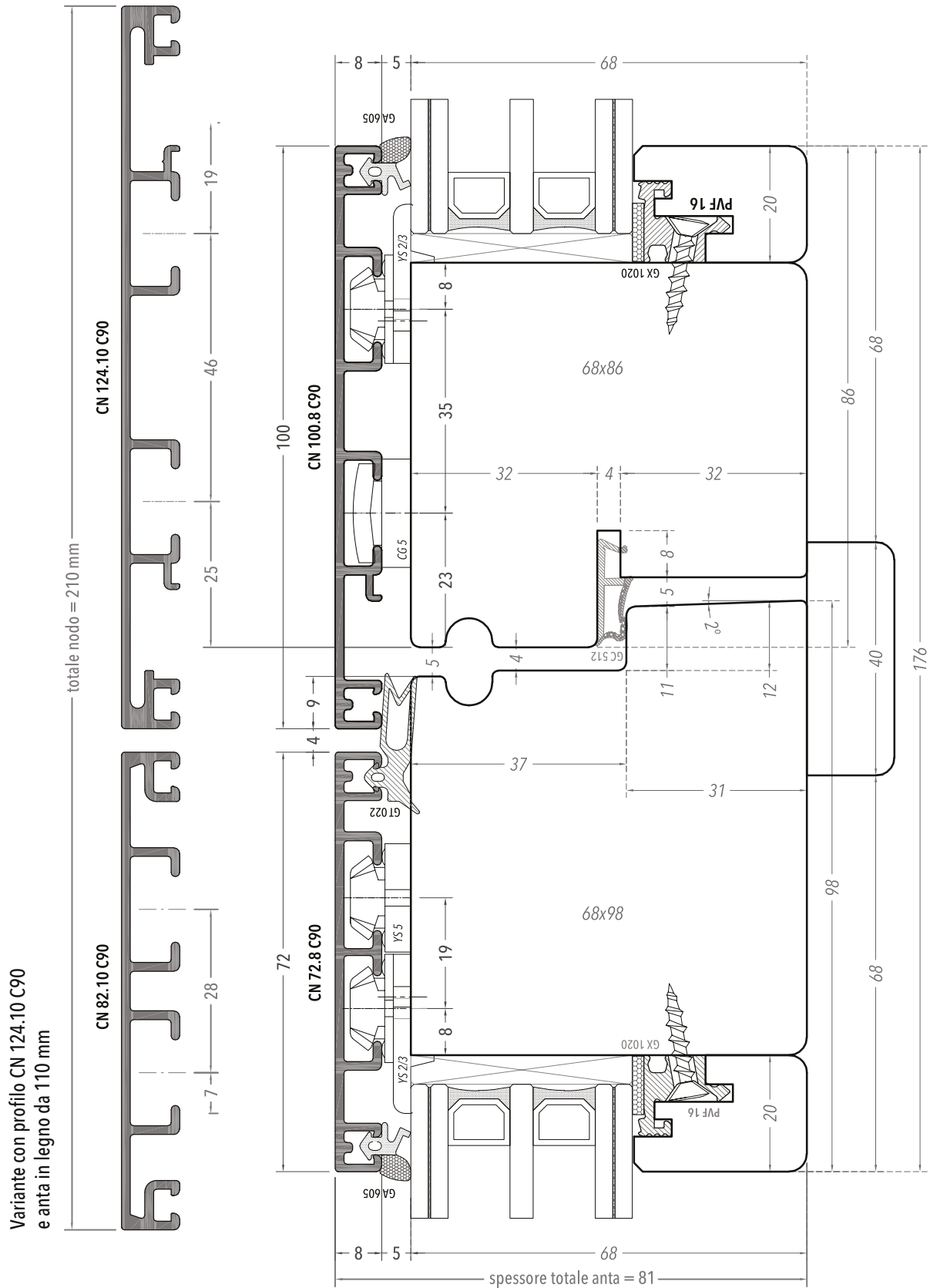

Profili anta forniti senza terminali.

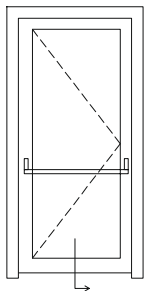

**PORTA AD APERTURA ESTERNA**

SEZIONE VERTICALE  
 NODO INFERIORE  
 SCALA 1:1

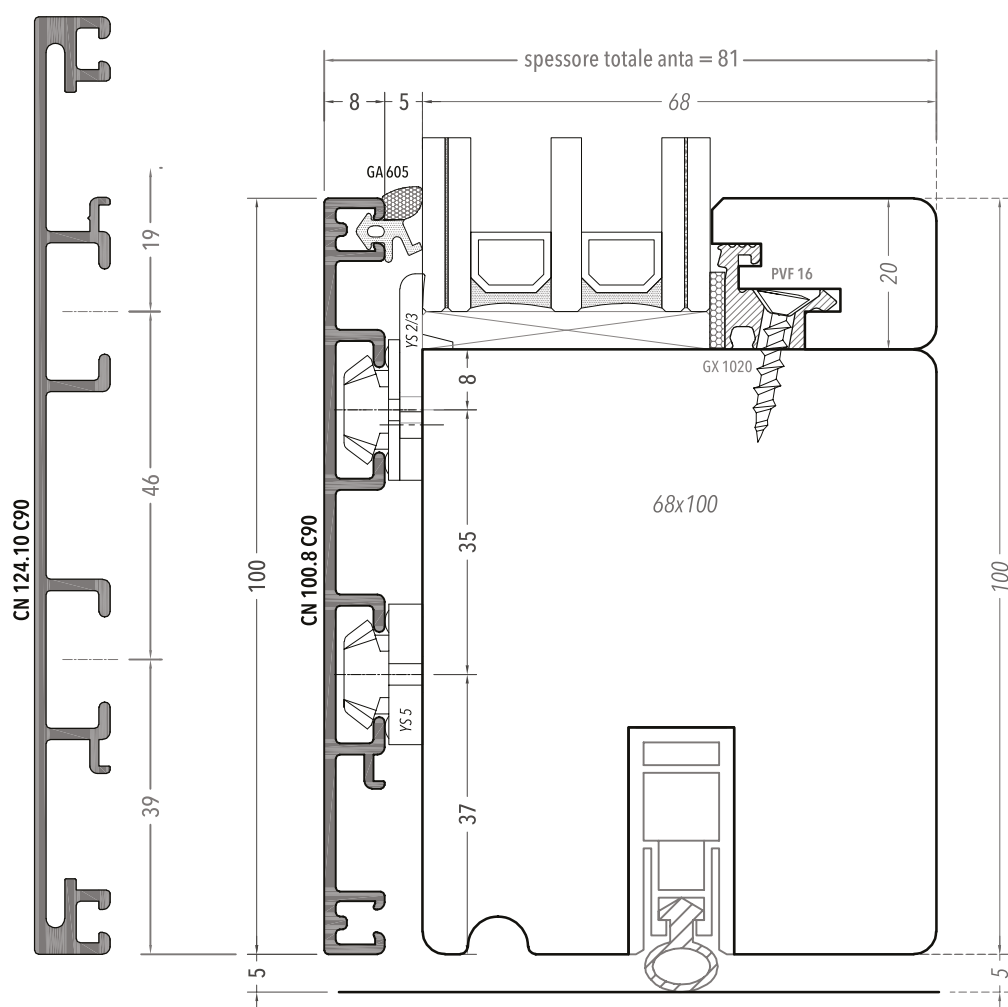

Profili anta forniti senza terminali.



# Alzanti scorrevoli

---

AGB

MAICO

GU

## SOLUZIONE ALTERNATIVA CON PROFILO K101

Soluzione alternativa con nuovo profilo KT01 per allineamento rivestimenti in alluminio e valida per tutte le proposte (AGB, Maico, GU), grazie alla quale si ottiene una notevole riduzione del legno nel traverso superiore (4)

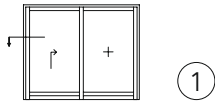

1

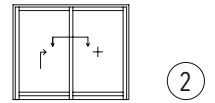
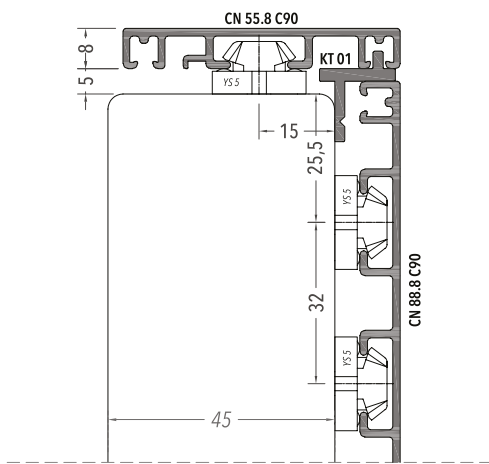

2

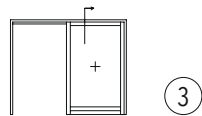
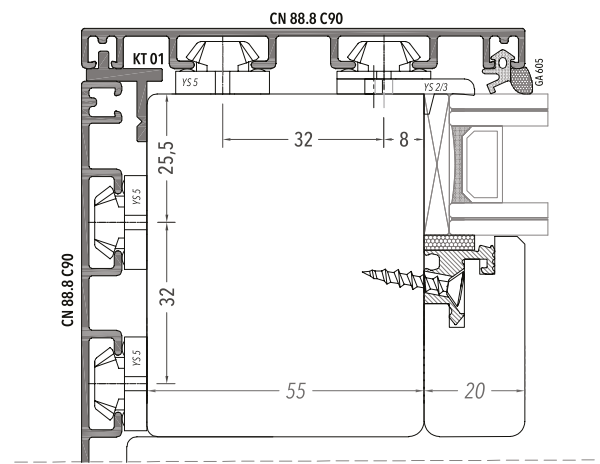

3

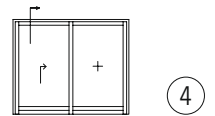
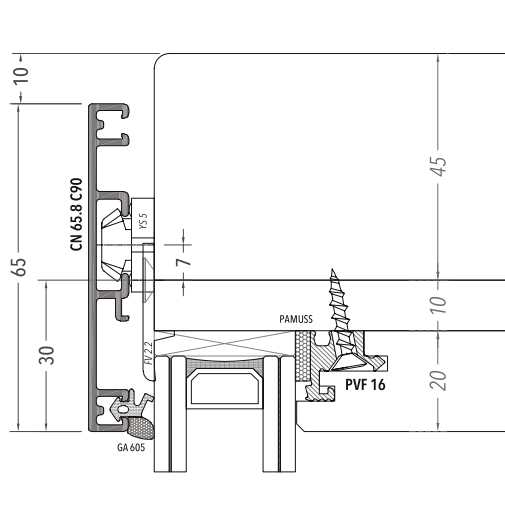

4

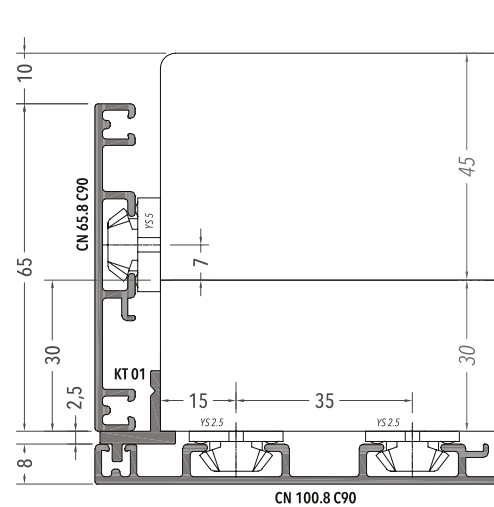



# Alzanti scorrevoli

---

AGB STANDARD

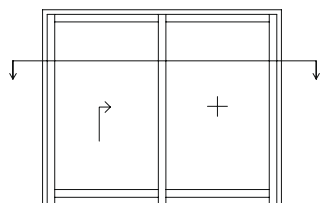

SEZIONE ORIZZONTALE  
SCALA 1:1.5

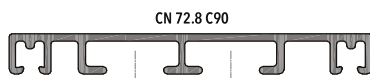
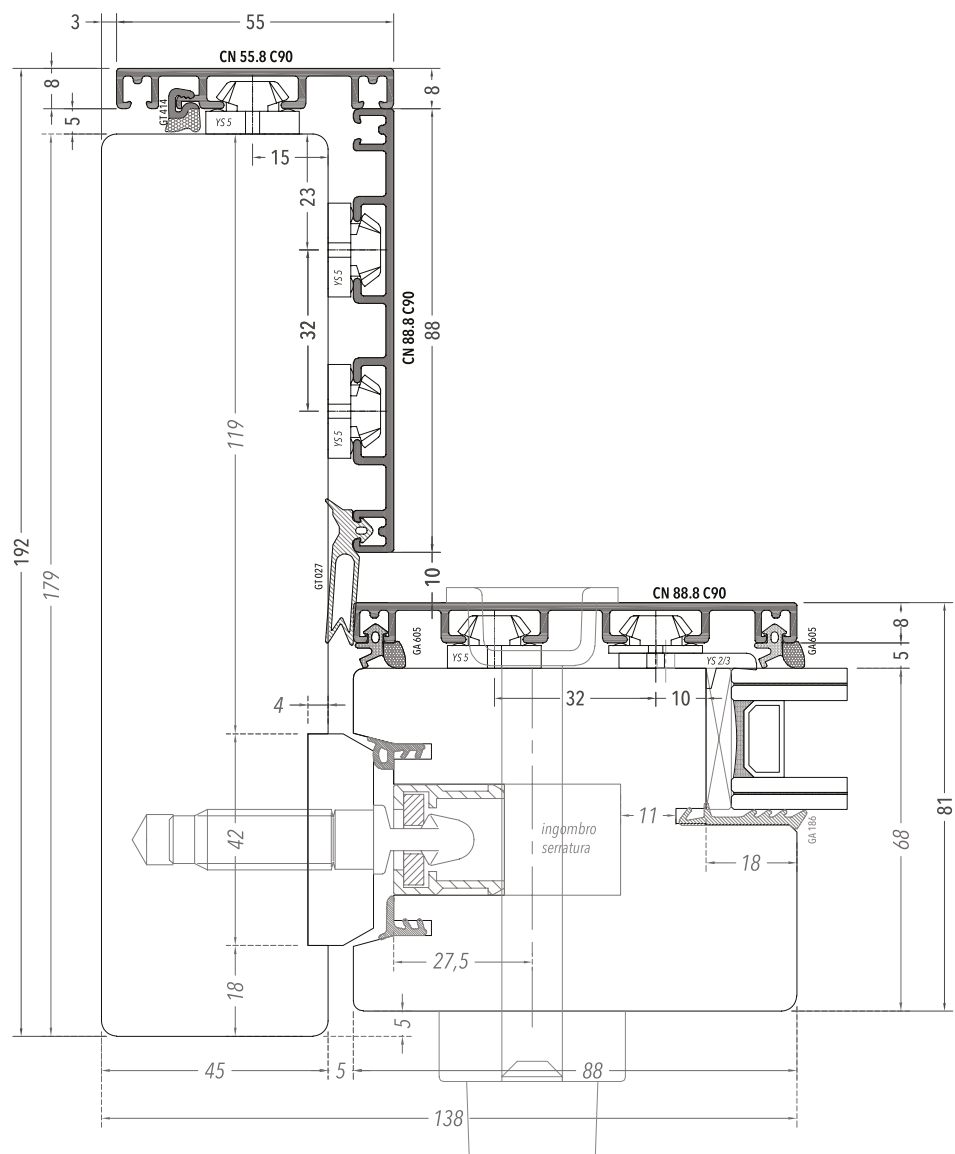

Variante con profilo di rivestimento  
CN 72.8 C90 (anta in legno da 74 mm)

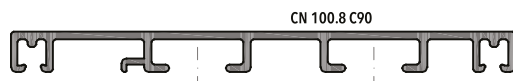

Variante con profilo di rivestimento  
CN 100.8 C90 (anta in legno da 100 mm)



Variante con profilo di rivestimento  
CN 110.8 C90 (anta in legno da 110 mm)

SEZIONE ORIZZONTALE  
SCALA 1:1.5

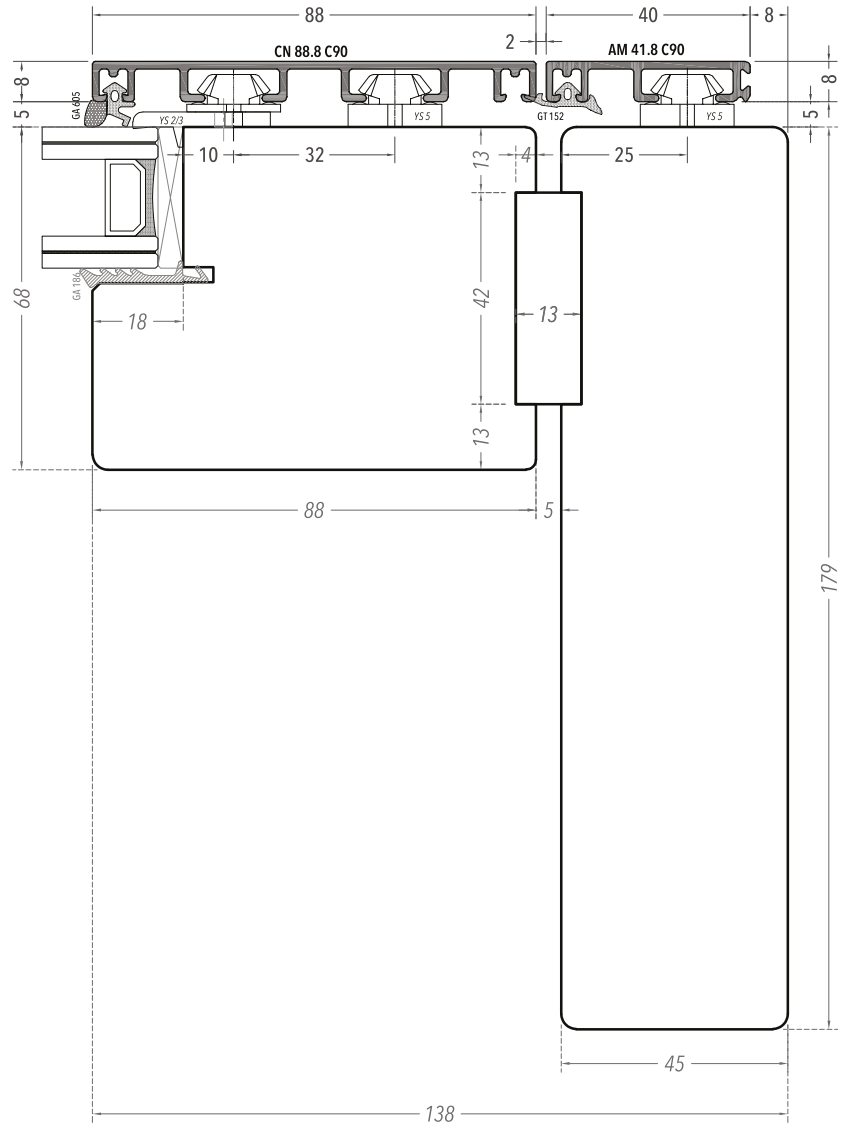
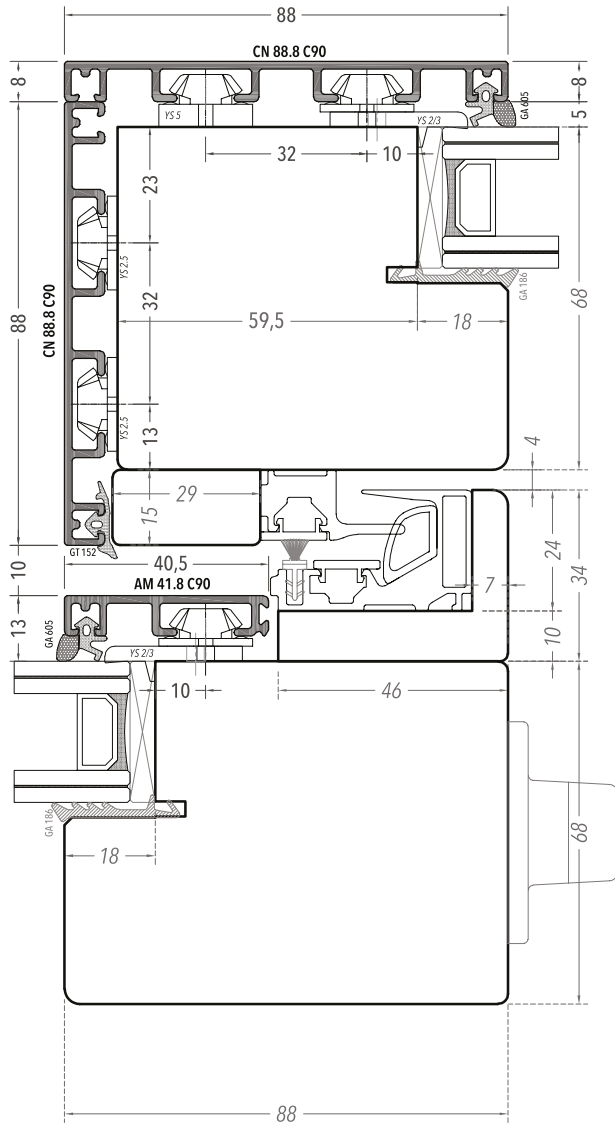

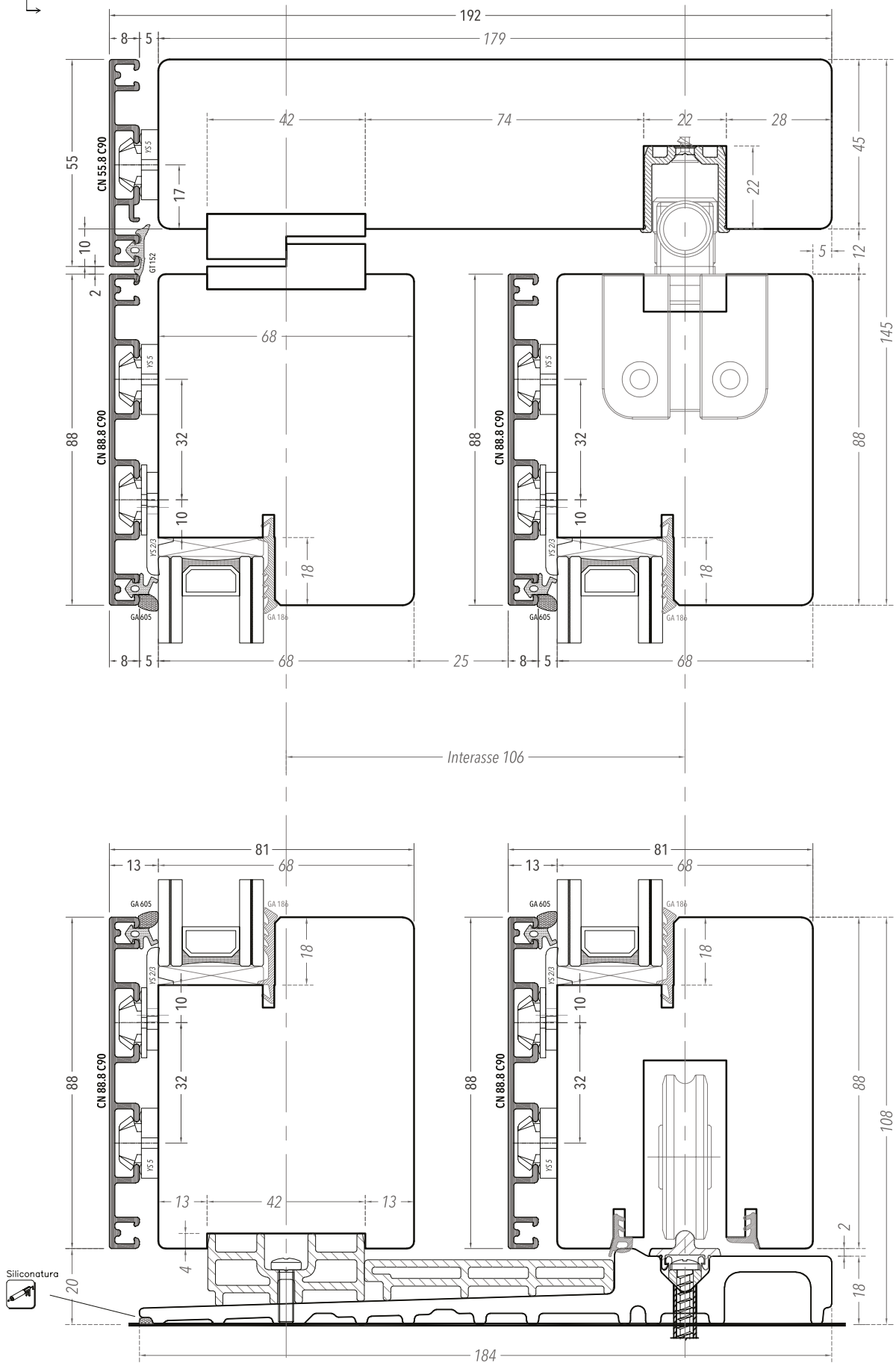
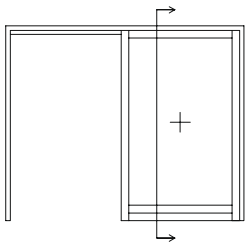

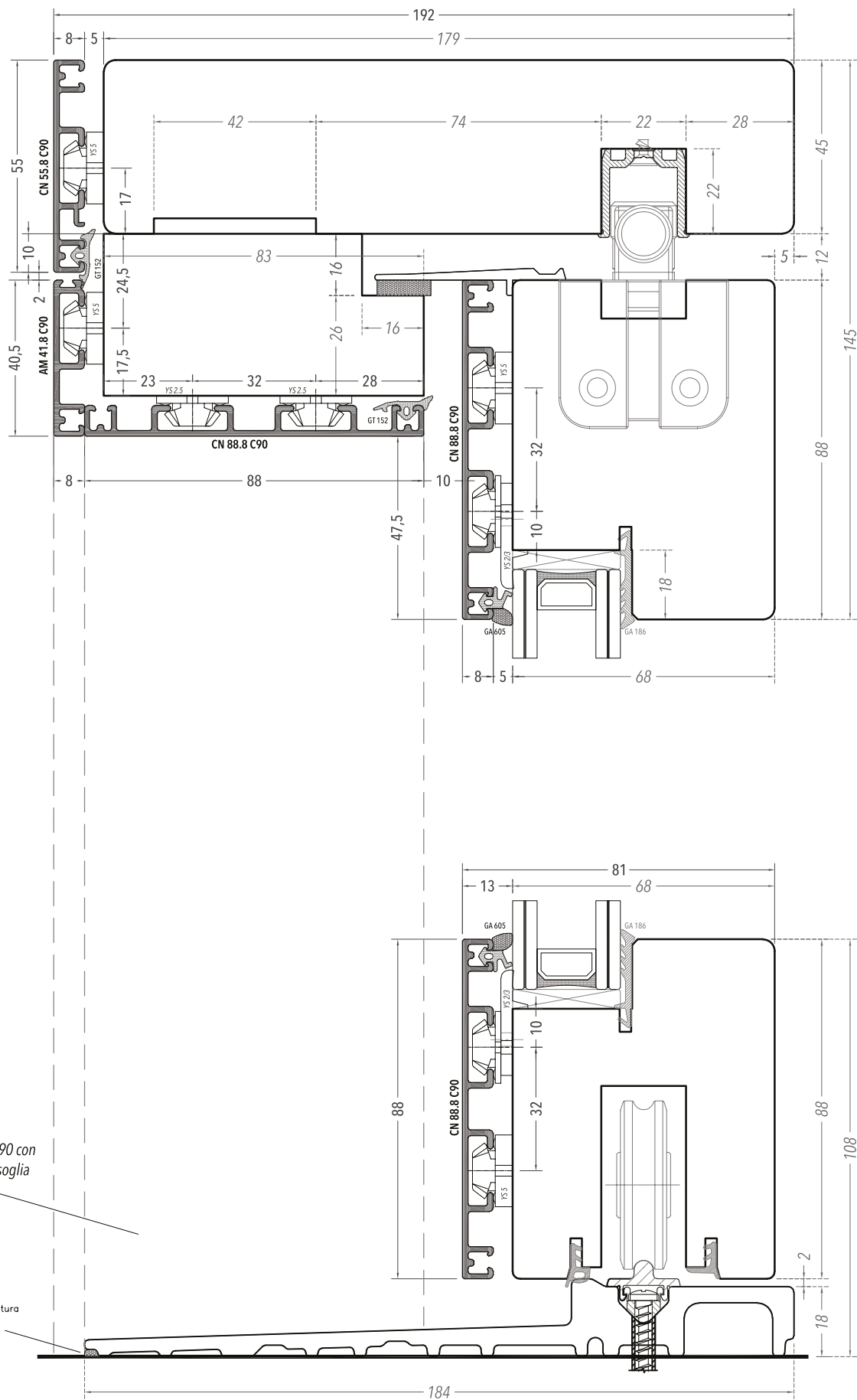
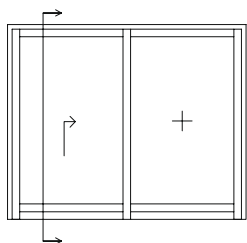

Tagliare il profilo CN 88.8 C90 con la stessa inclinazione della soglia





# Alzanti scorrevoli

---

AGB DOPPIA ANTA  
SCORREVOLE

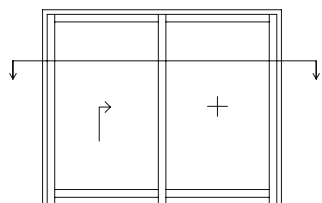

SEZIONE ORIZZONTALE  
SCALA 1:1.5

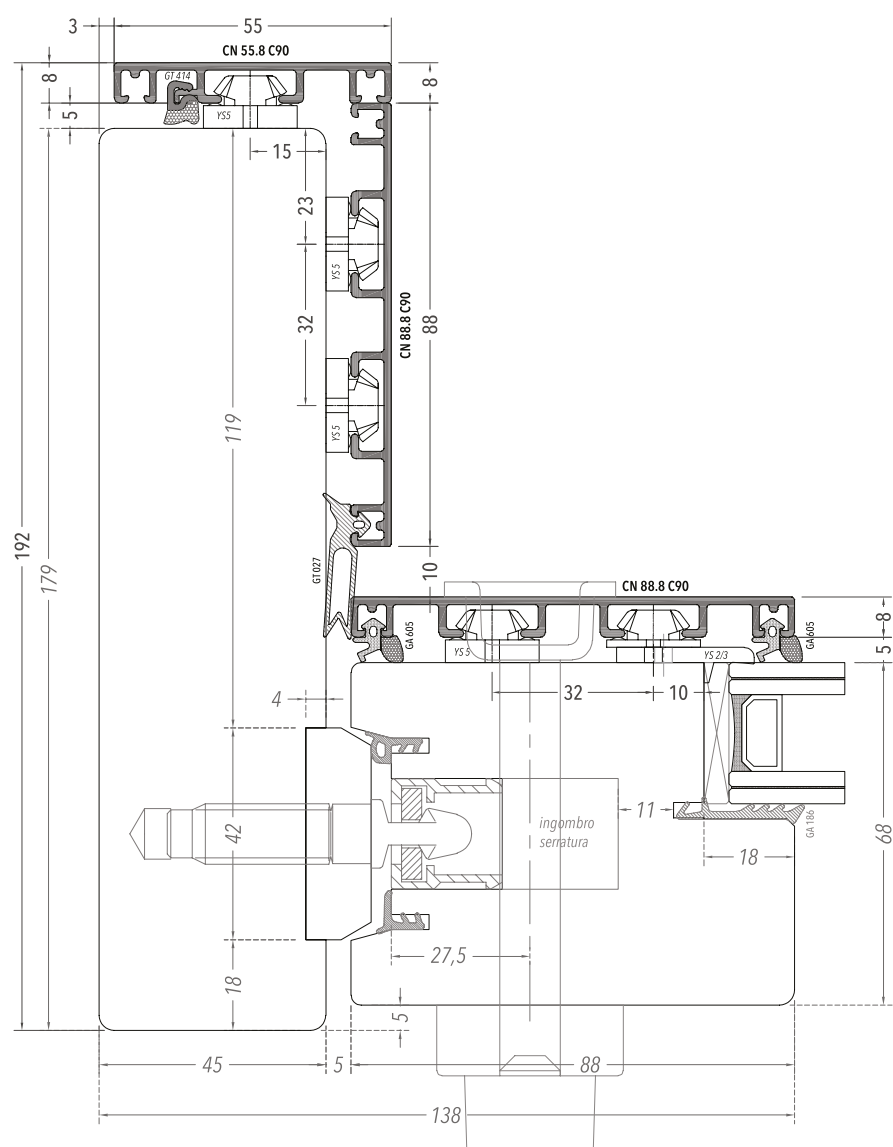

Variante con profilo di rivestimento  
CN 72.8 C90 (anta in legno da 74 mm)

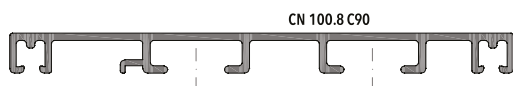

Variante con profilo di rivestimento  
CN 100.8 C90 (anta in legno da 100 mm)

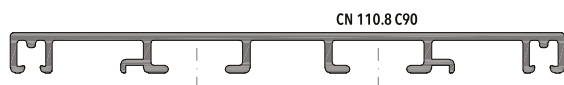

Variante con profilo di rivestimento  
CN 110.8 C90 (anta in legno da 110 mm)



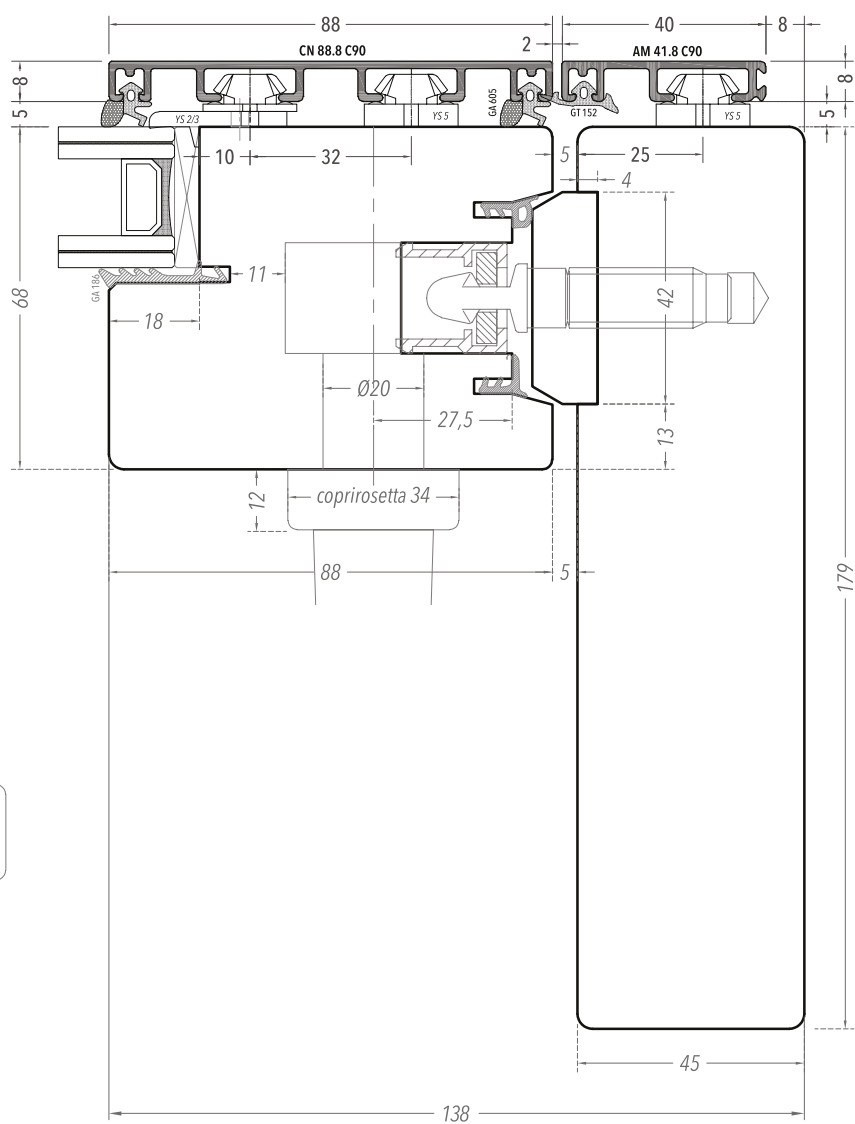
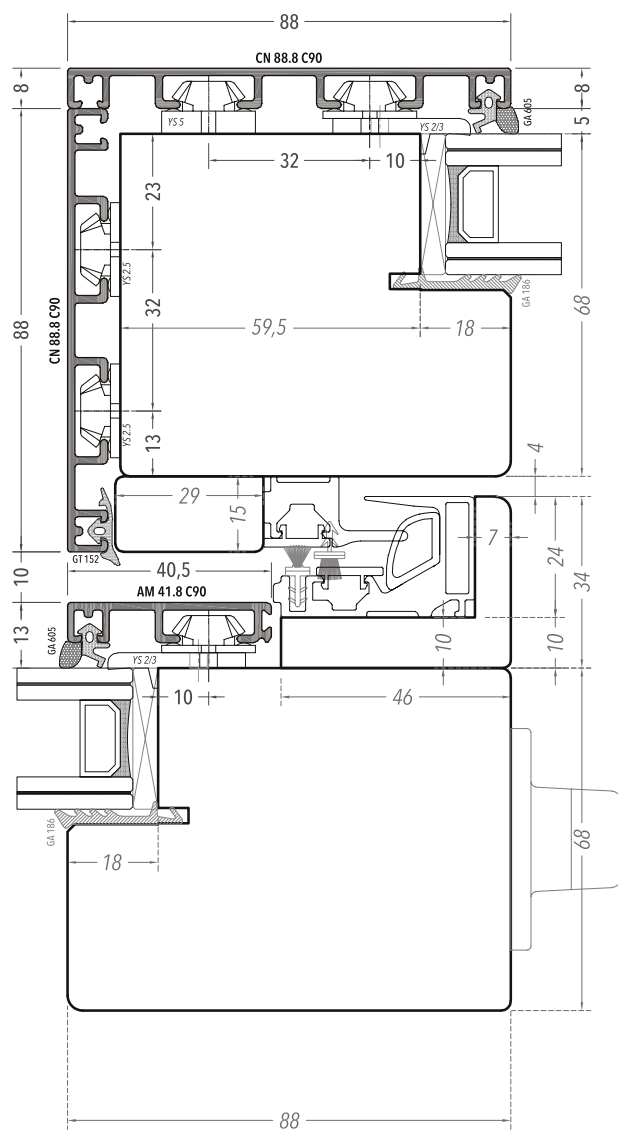

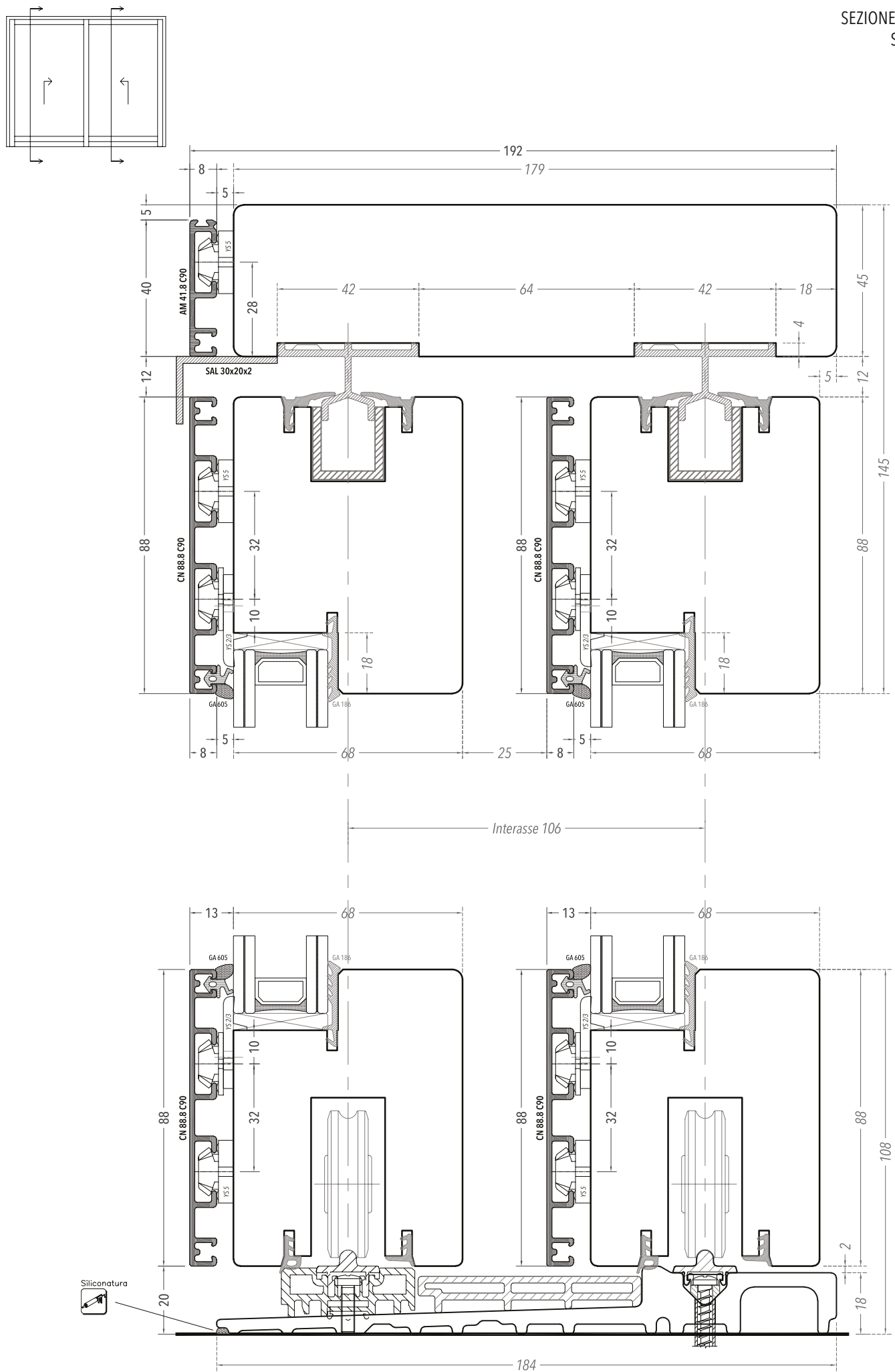

# Alzanti scorrevoli

---

AGB IMAGO

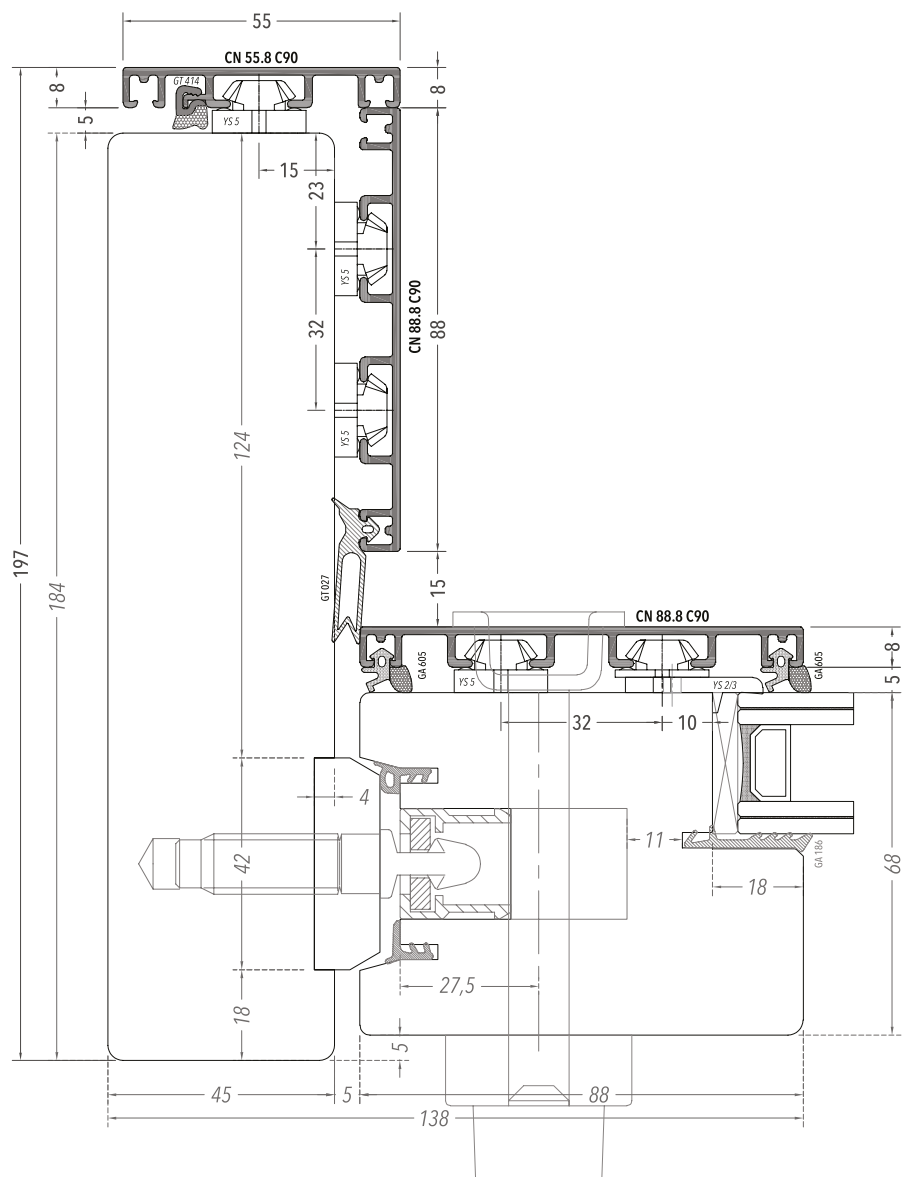
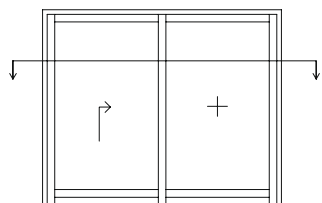

Variante con profilo di rivestimento  
CN 72.8 C90 (anta in legno da 74 mm)

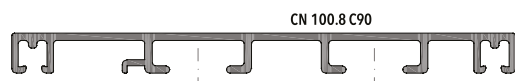

Variante con profilo di rivestimento  
CN 100.8 C90 (anta in legno da 100 mm)



Variante con profilo di rivestimento  
CN 110.8 C90 (anta in legno da 110 mm)

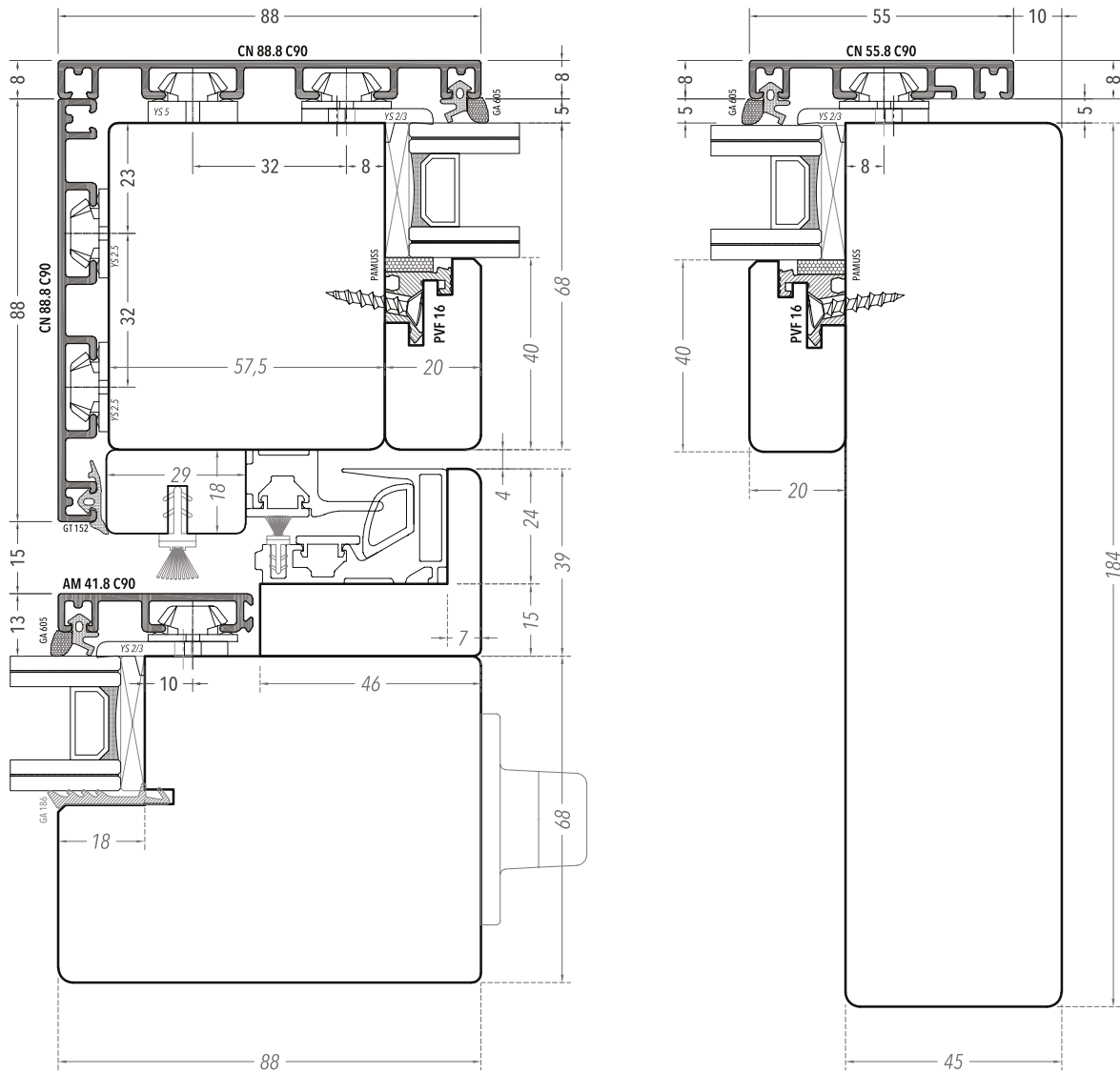

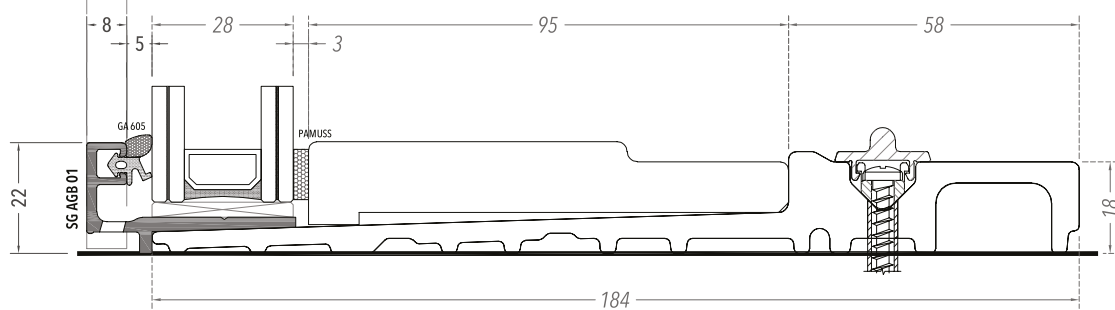
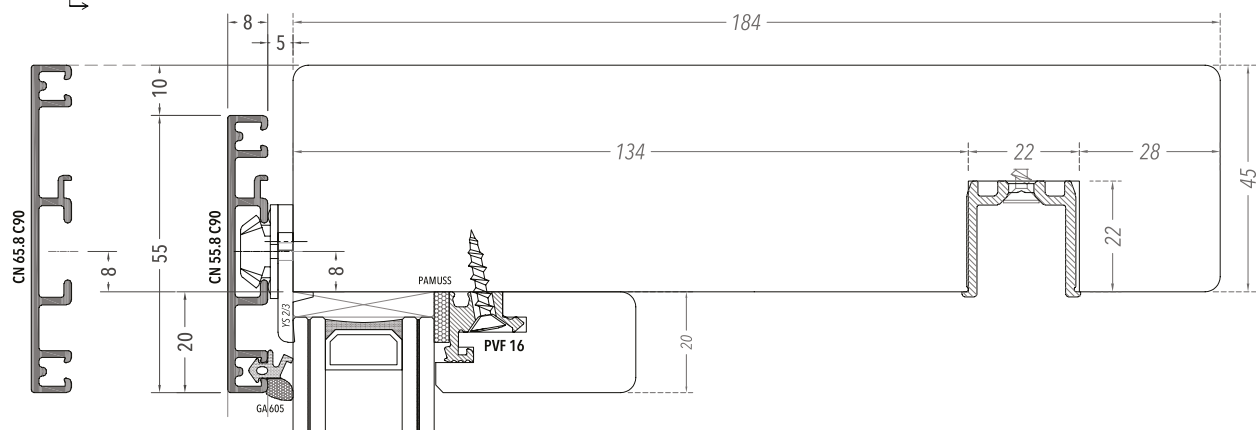
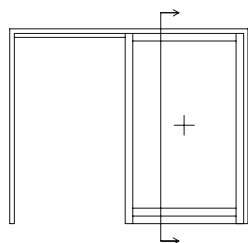

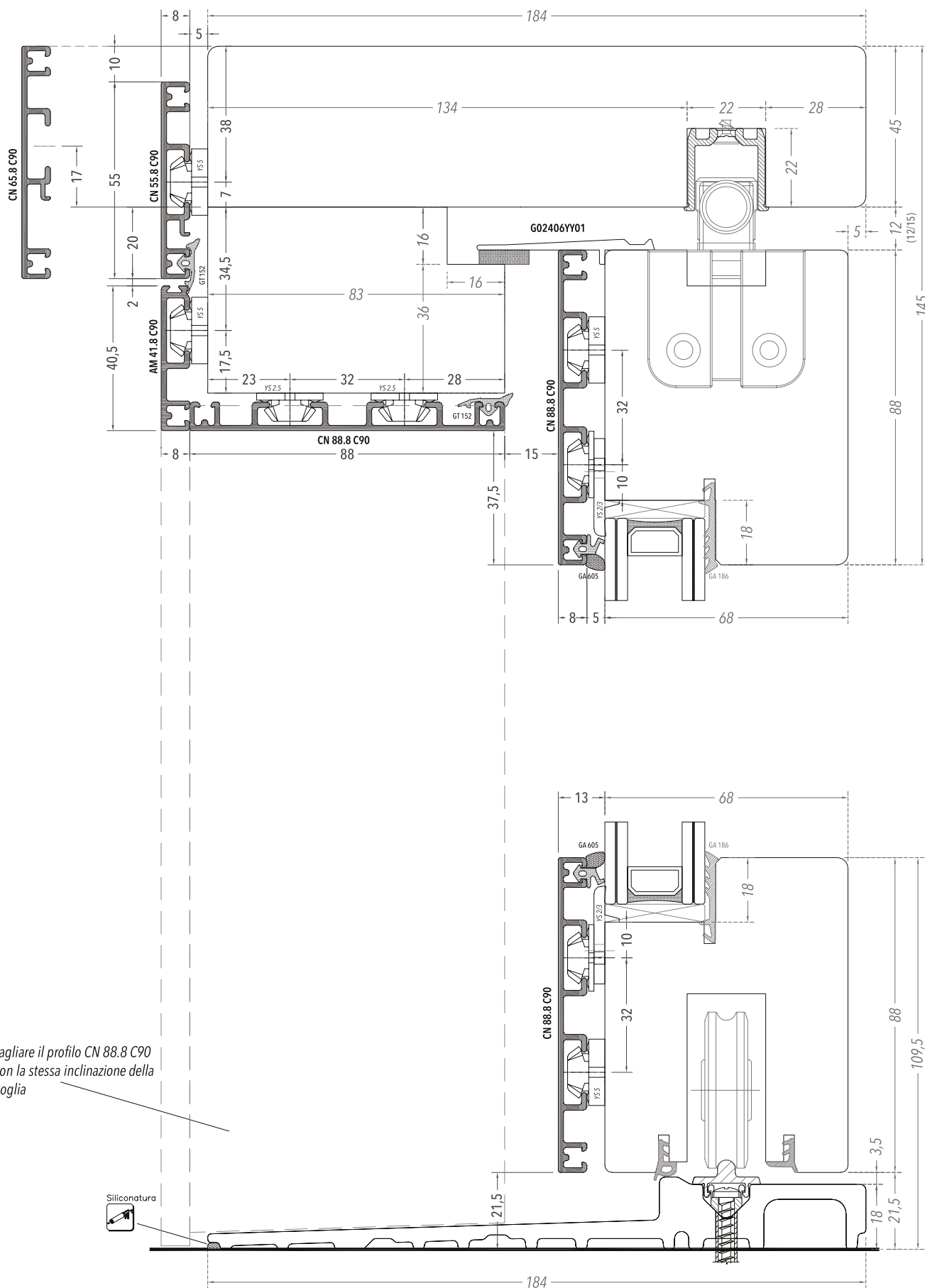
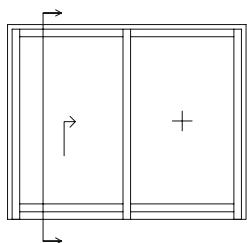

Tagliare il profilo CN 88.8 C90  
con la stessa inclinazione della  
soglia







# Alzanti scorrevoli

---

AGB IMAGO

RIDOTTO

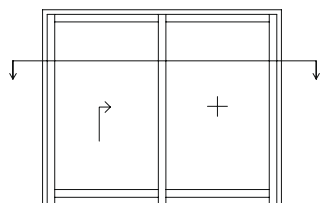

SEZIONE ORIZZONTALE  
SCALA 1:1.5

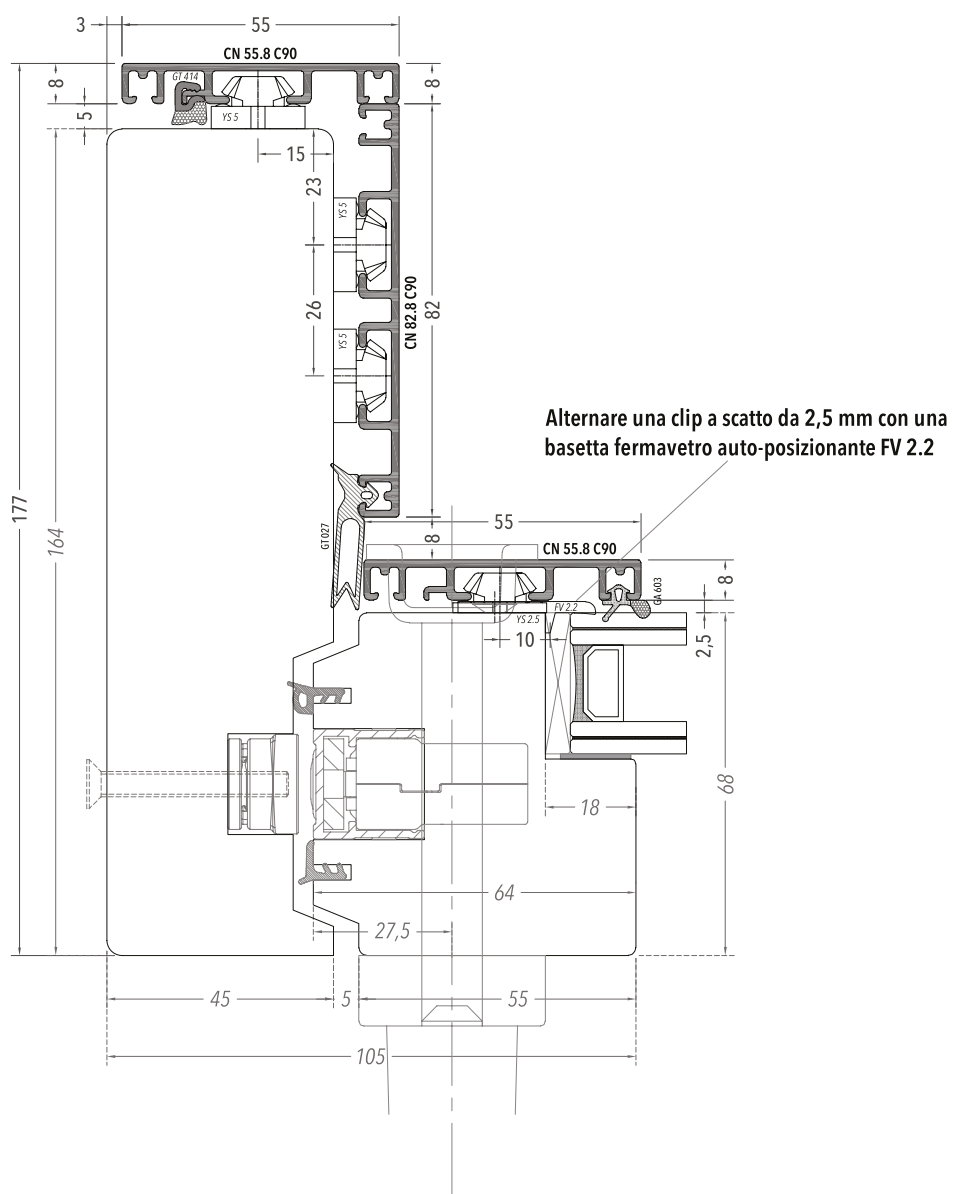

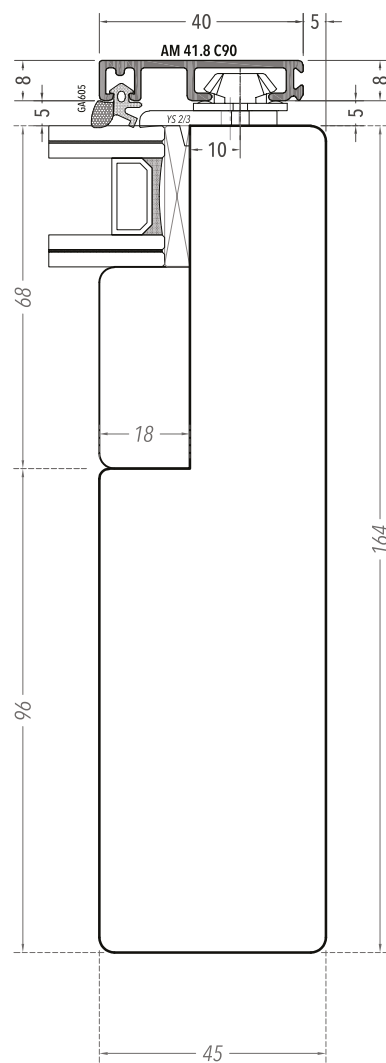
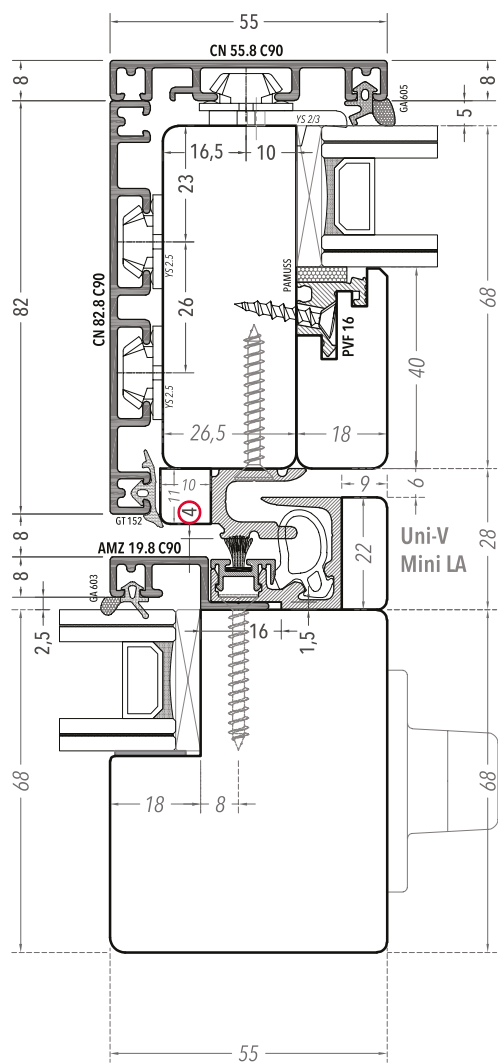

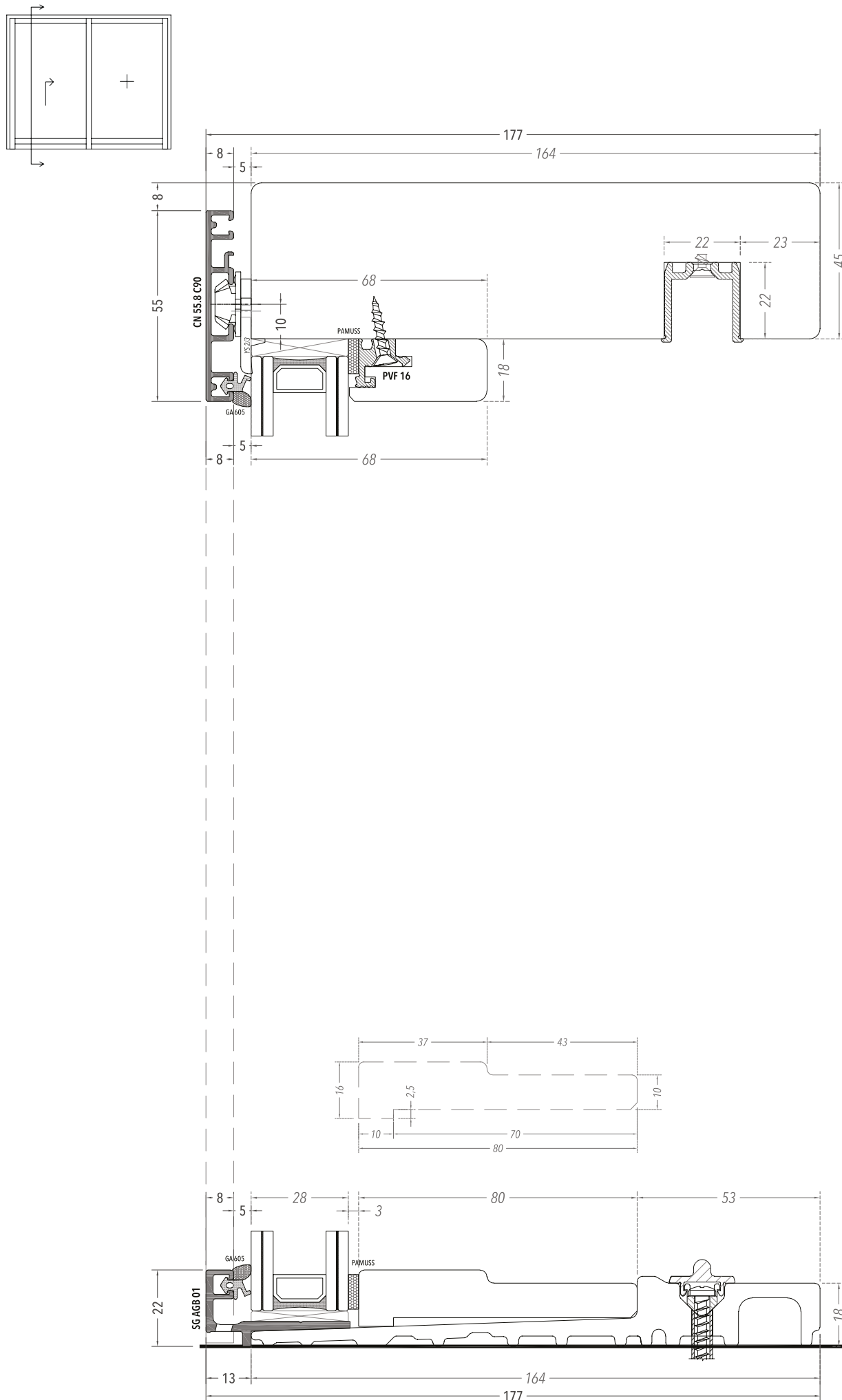

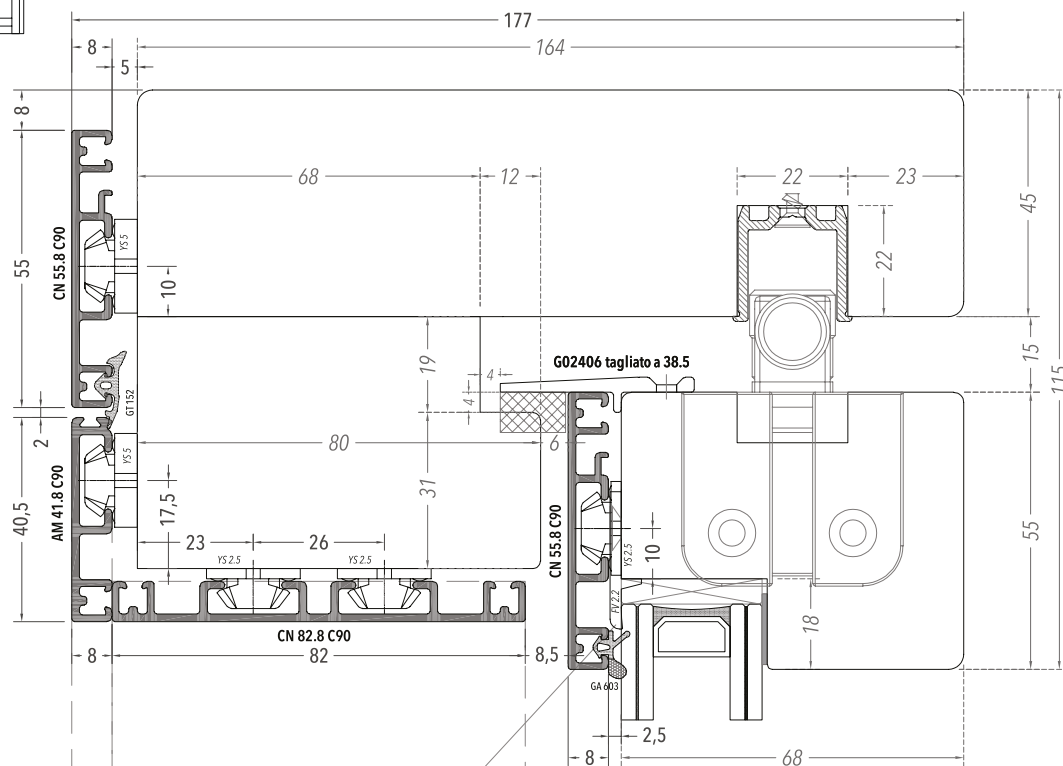
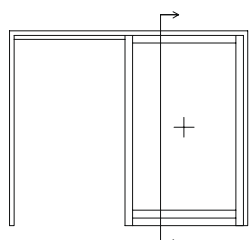

Alternare una clip a scatto da 2,5 mm con una basetta fermavetro auto-posizionante FV 2.2

Alternare una clip a scatto da 2,5 mm con una basetta fermavetro auto-posizionante FV 2.2

Tagliare il profilo CN 82.8 C90 con la stessa inclinazione della soglia

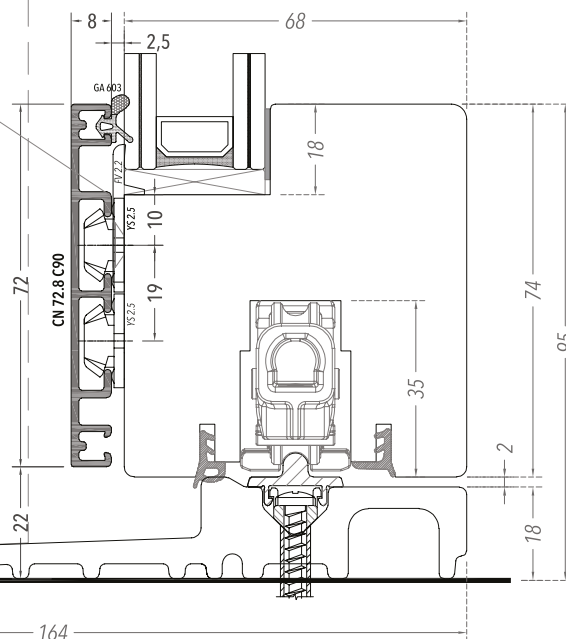



# Alzanti scorrevoli

---

MAICO  
STANDARD

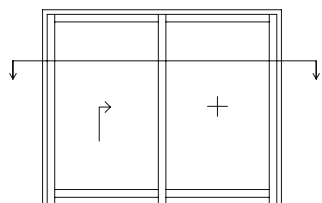

SEZIONE ORIZZONTALE  
SCALA 1:1.5

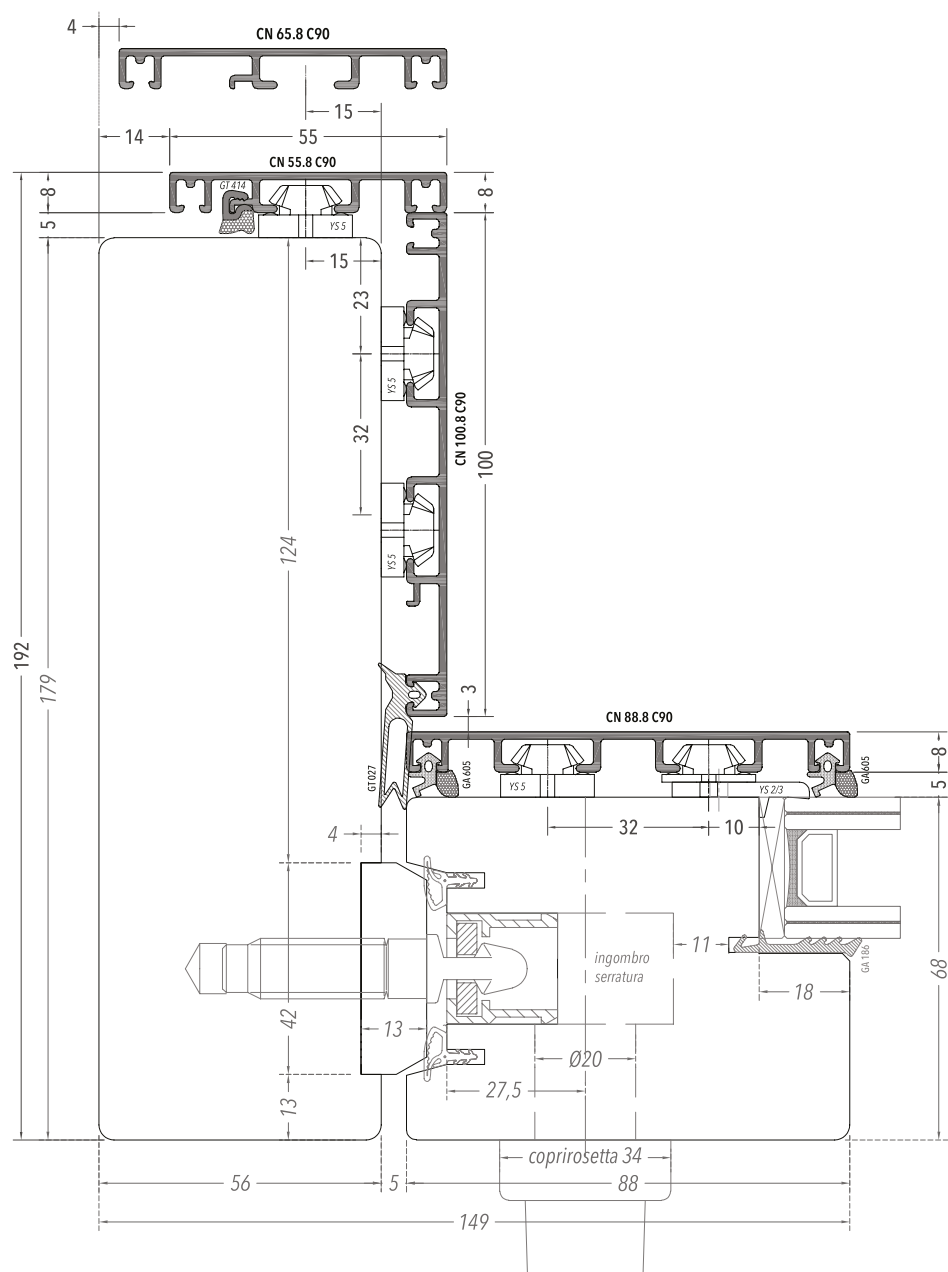

**SCHEMA A**



Variante con profilo di rivestimento  
CN 72.8 C90 con chiusura centrale  
in legno (anta in legno da 74 mm)

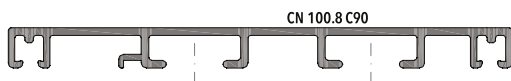

Variante con profilo di rivestimento  
CN 100.8 C90 (anta in legno da 100 mm)



Variante con profilo di rivestimento  
CN 110.8 C90 (anta in legno da 110 mm)



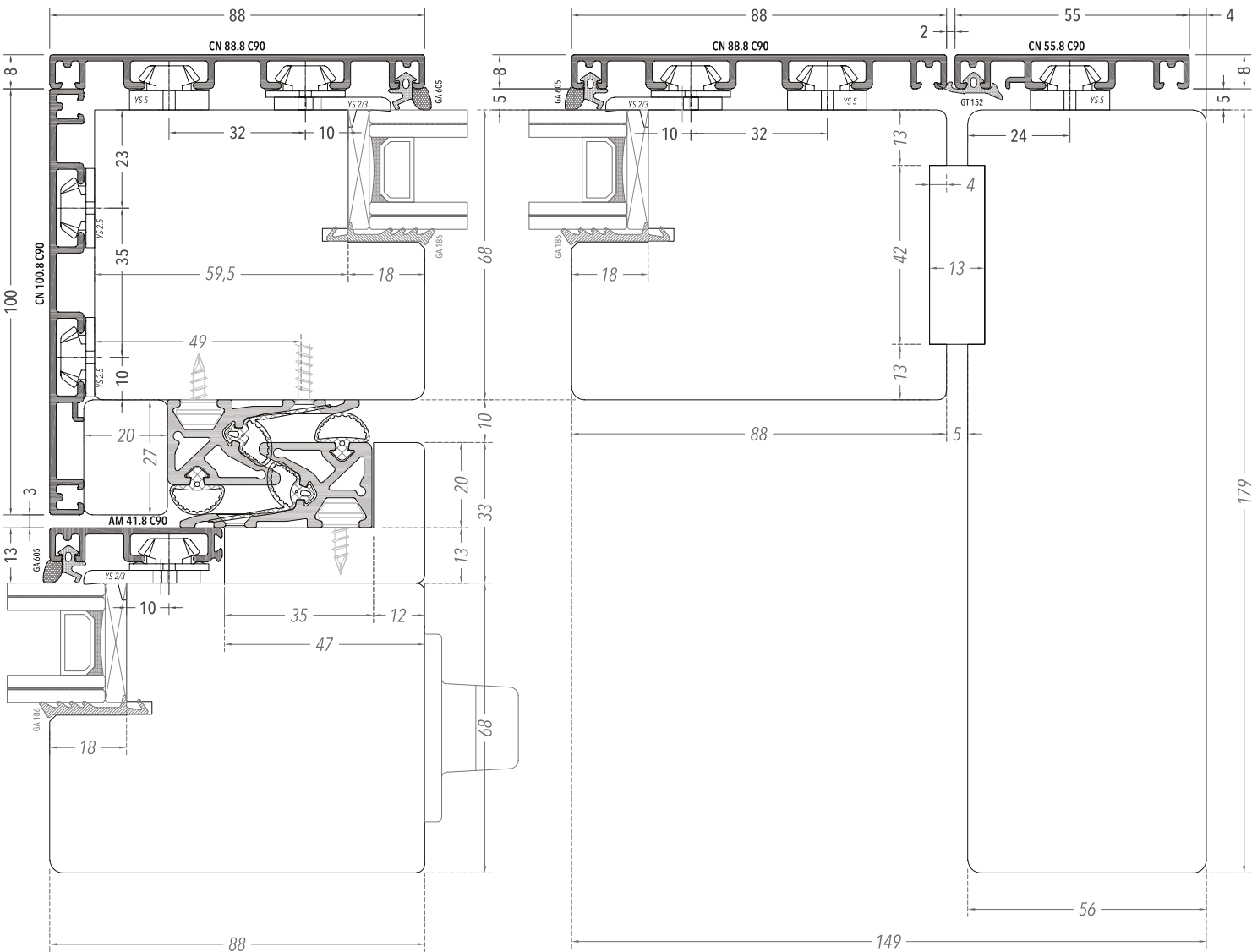

**SCHEMA C - 4 ANTE**

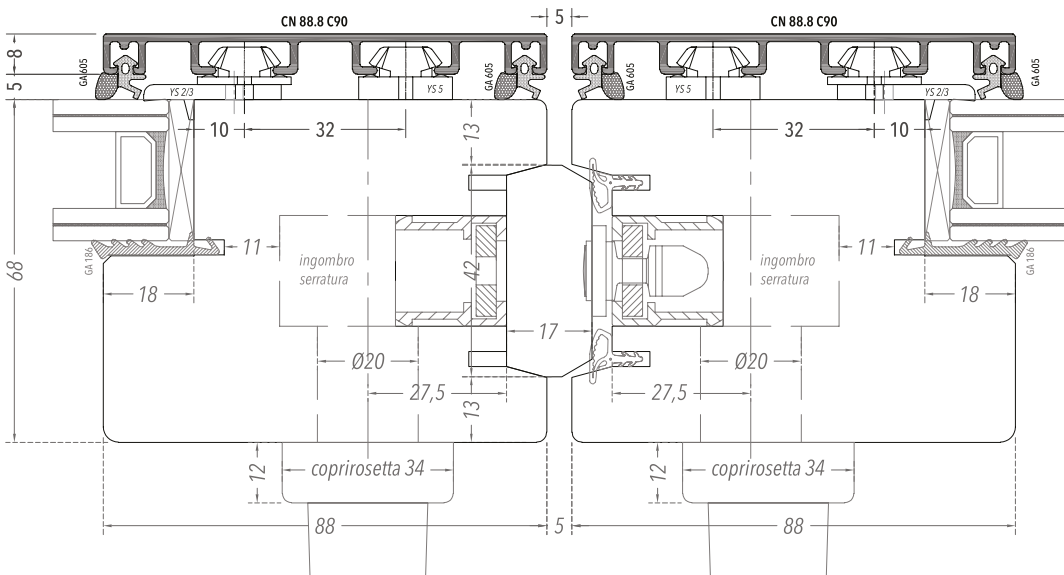

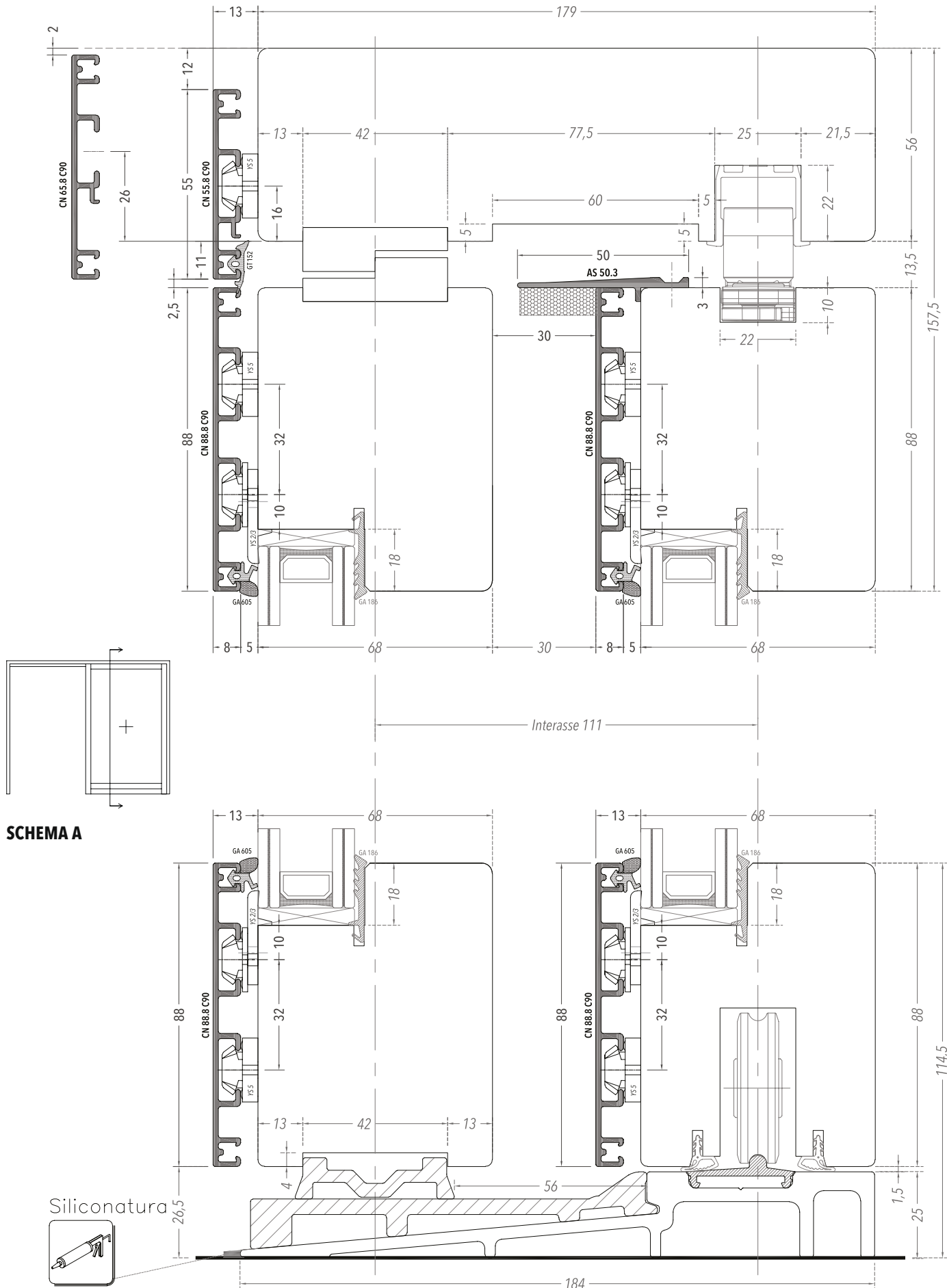





# Alzanti scorrevoli

---

MAICO

DOPPIA ANTA

SCORREVOLE

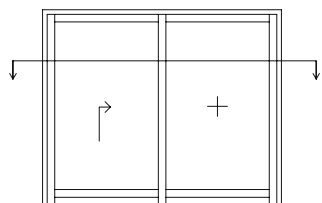

SEZIONE ORIZZONTALE  
SCALA 1:1.5

**SCHEMA D**

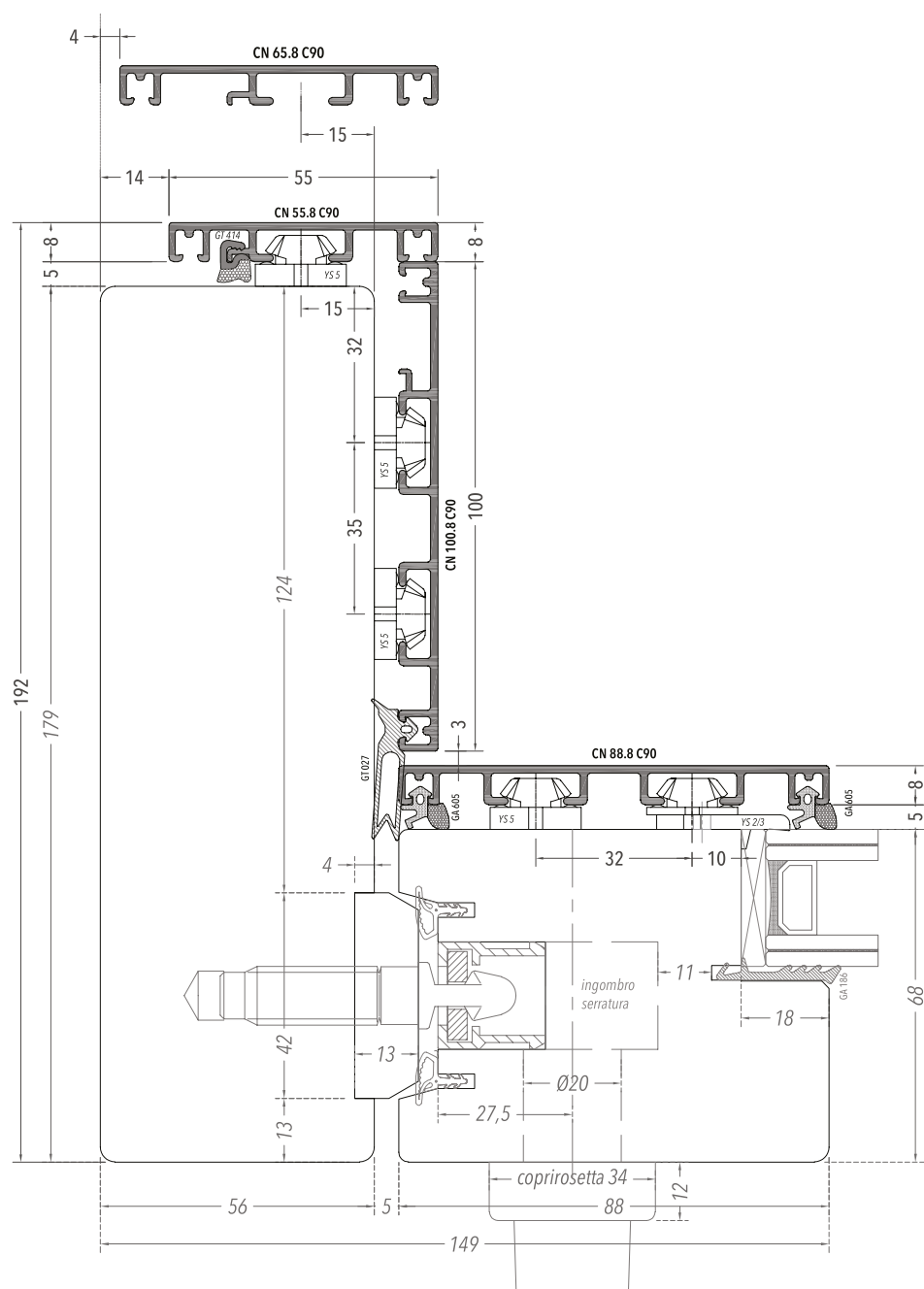

Variante con profilo di rivestimento  
CN 72.8 C90 (anta in legno da 74 mm)

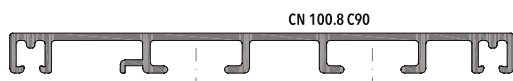

Variante con profilo di rivestimento  
CN 100.8 C90 (anta in legno da 100 mm)



Variante con profilo di rivestimento  
CN 110.8 C90 (anta in legno da 110 mm)



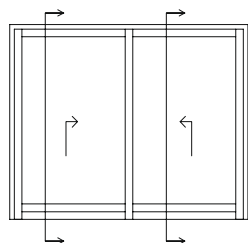

SCHEMA D

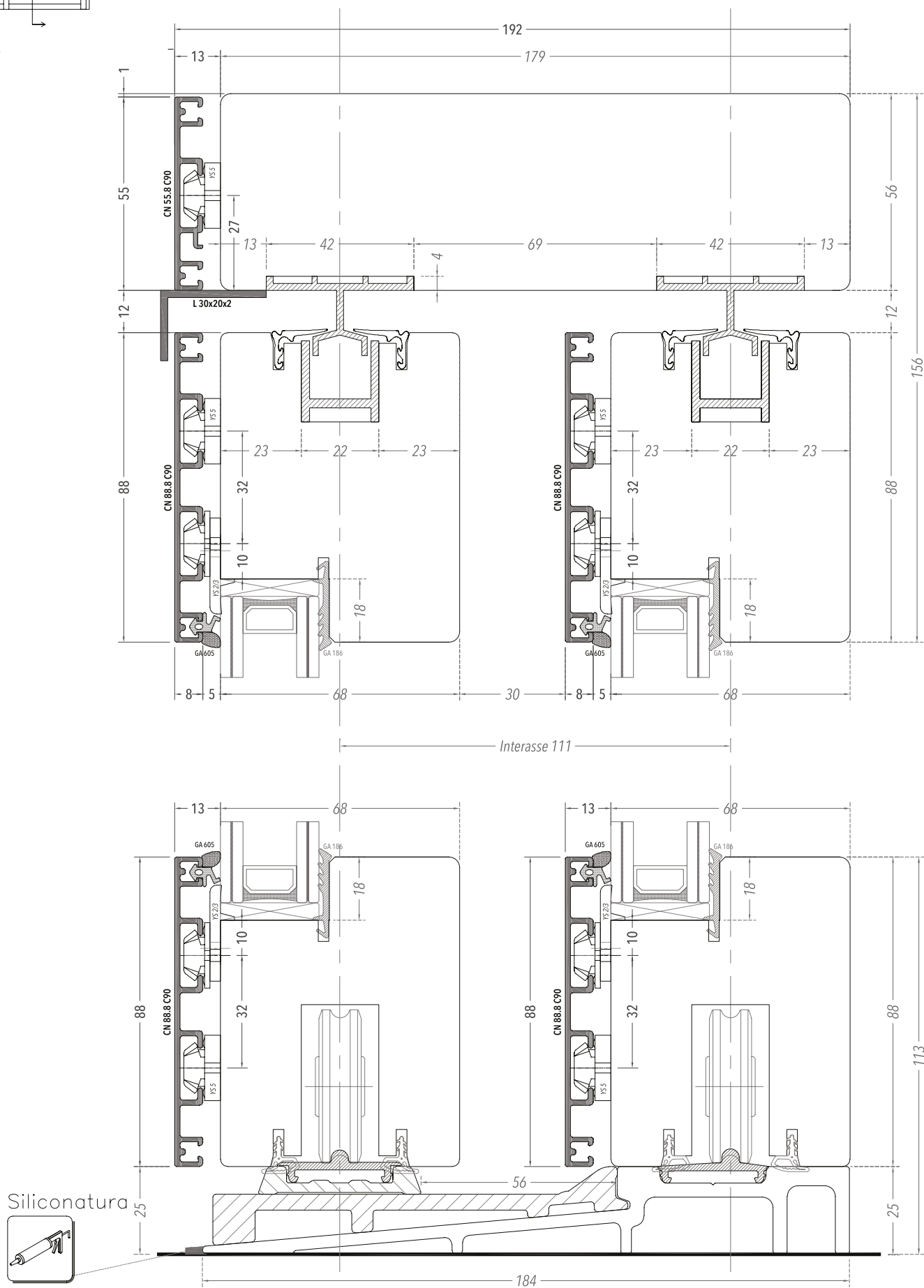



# Alzanti scorrevoli

---

MAICO LUCE

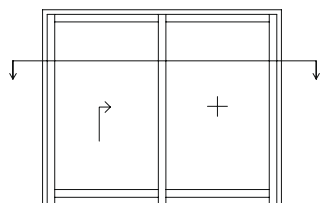

SEZIONE ORIZZONTALE  
SCALA 1:1.5

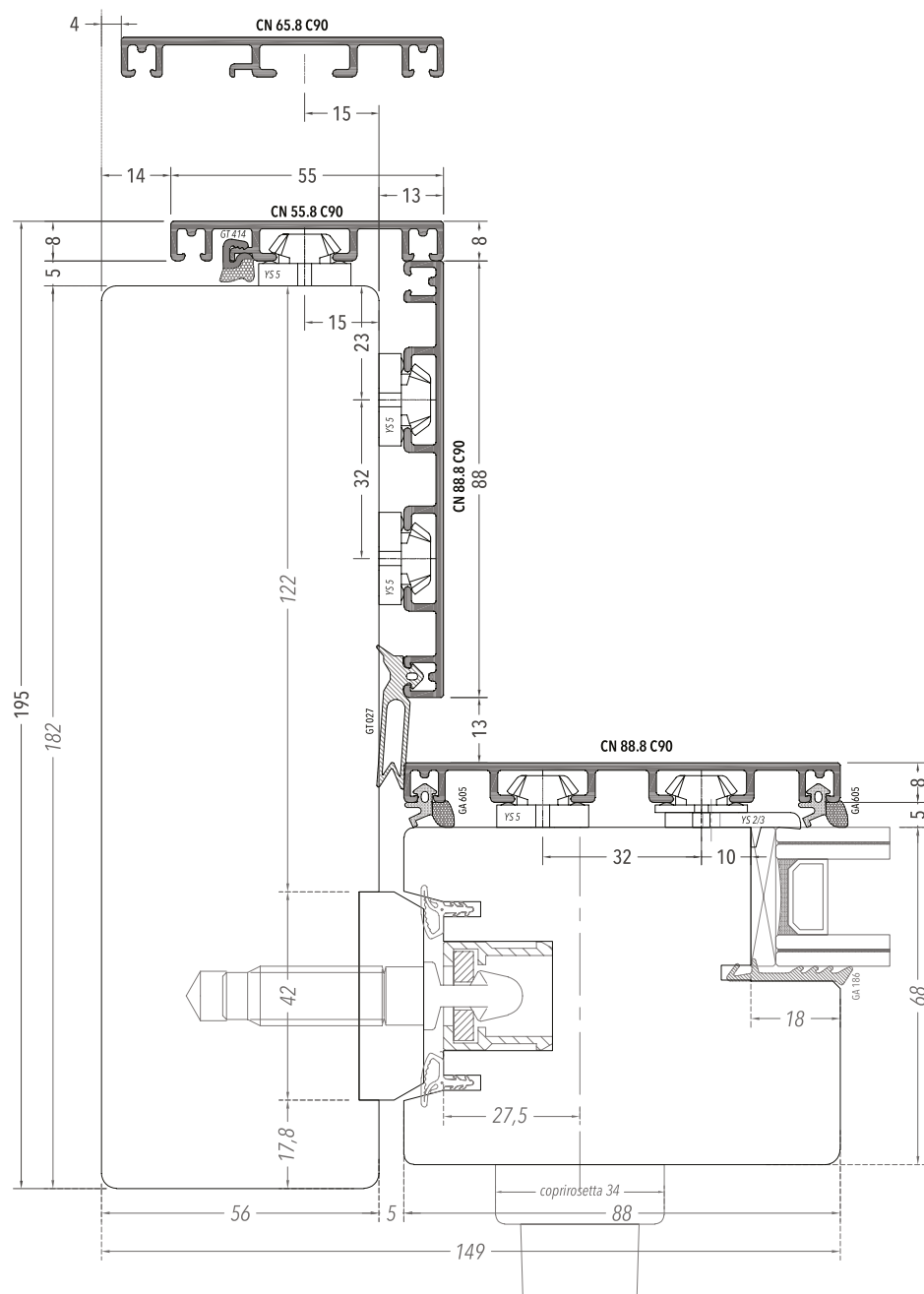

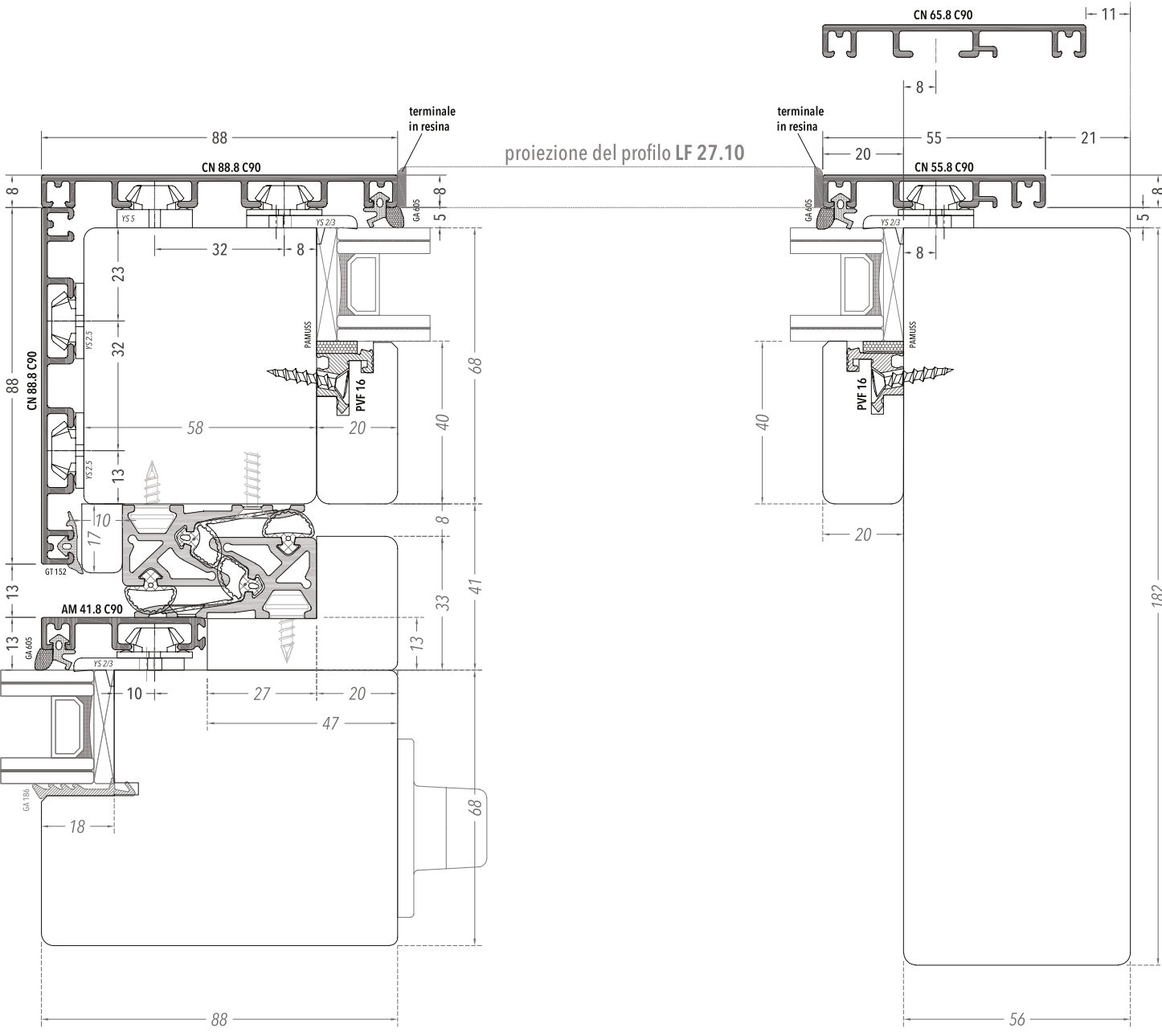

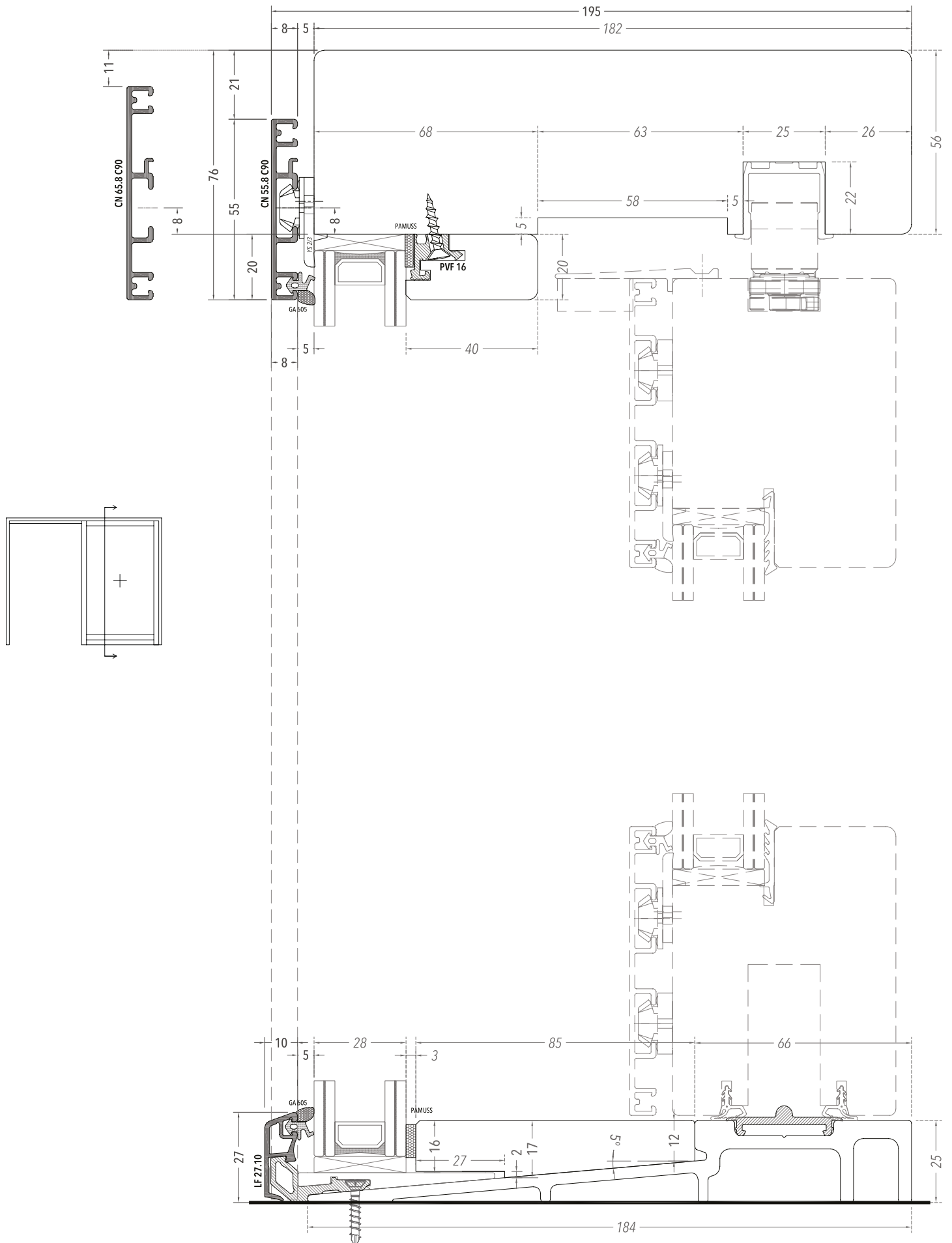





# Alzanti scorrevoli

---

MAICO

INFINITY VIEW





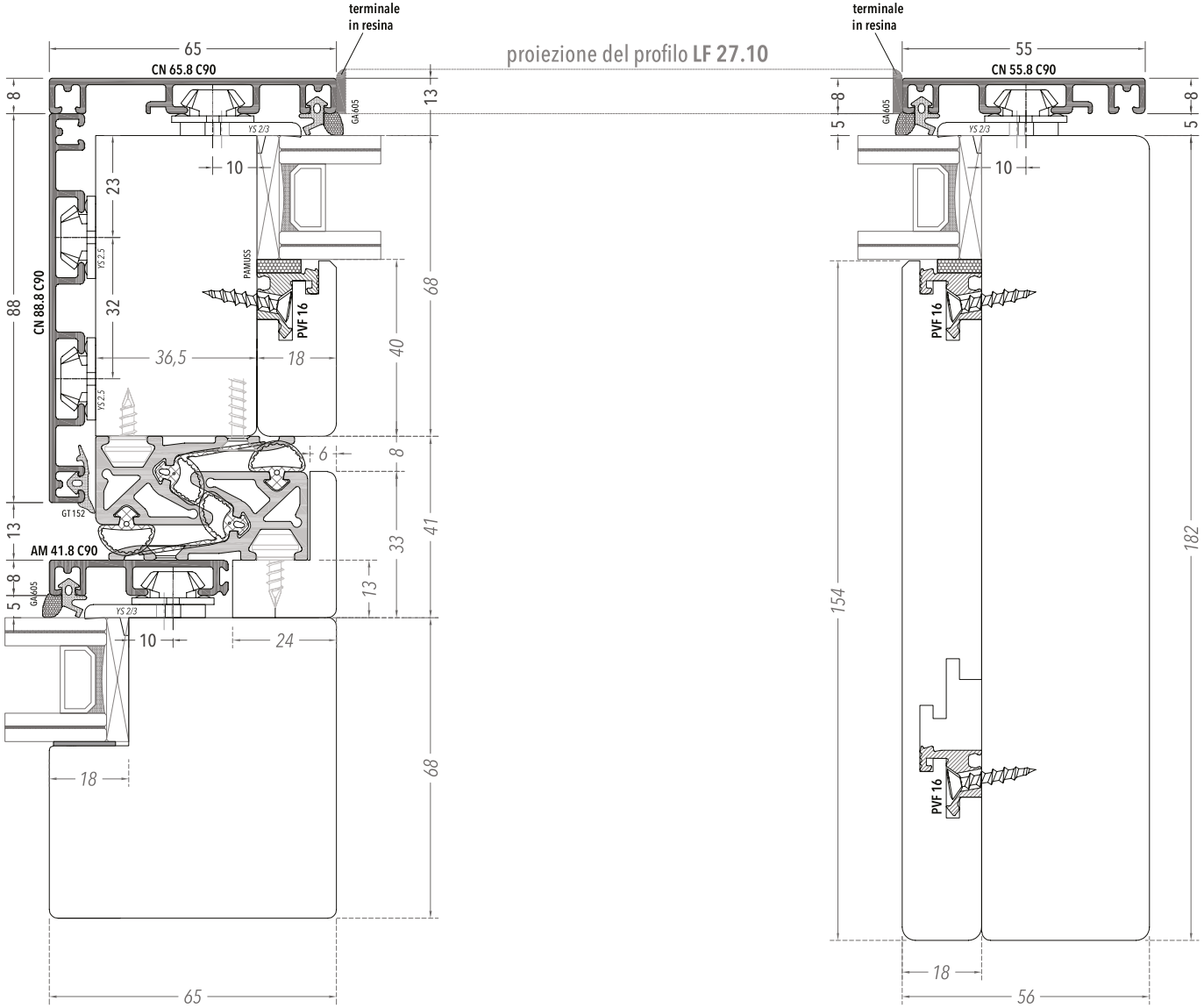

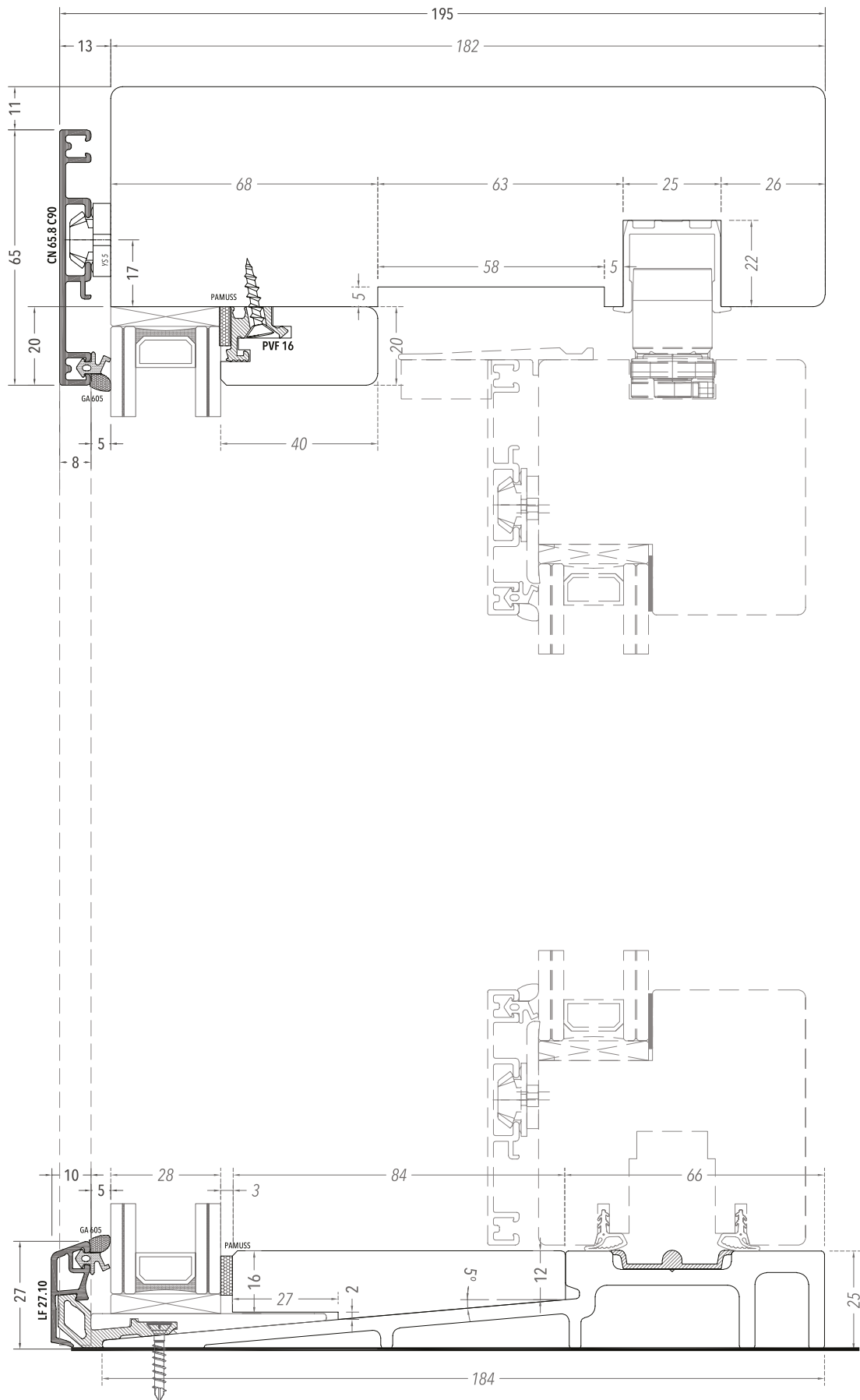
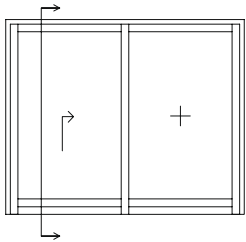

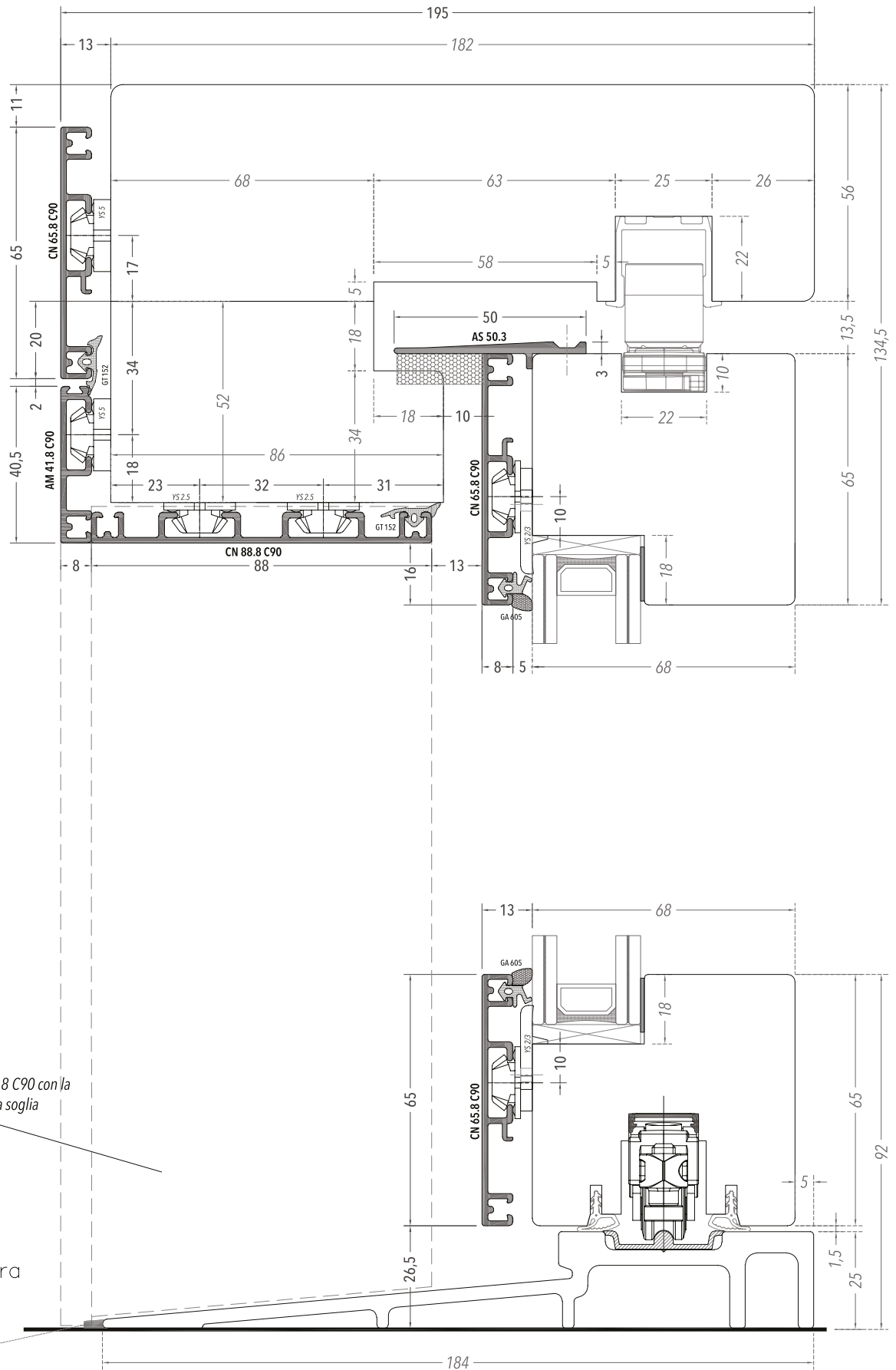
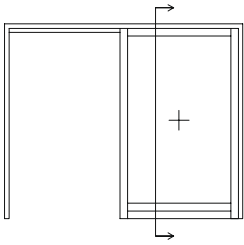

Tagliare il profilo CN 88.8 C90 con la stessa inclinazione della soglia

Siliconatura

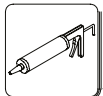



# Alzanti scorrevoli

---

GU STANDARD

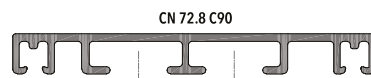
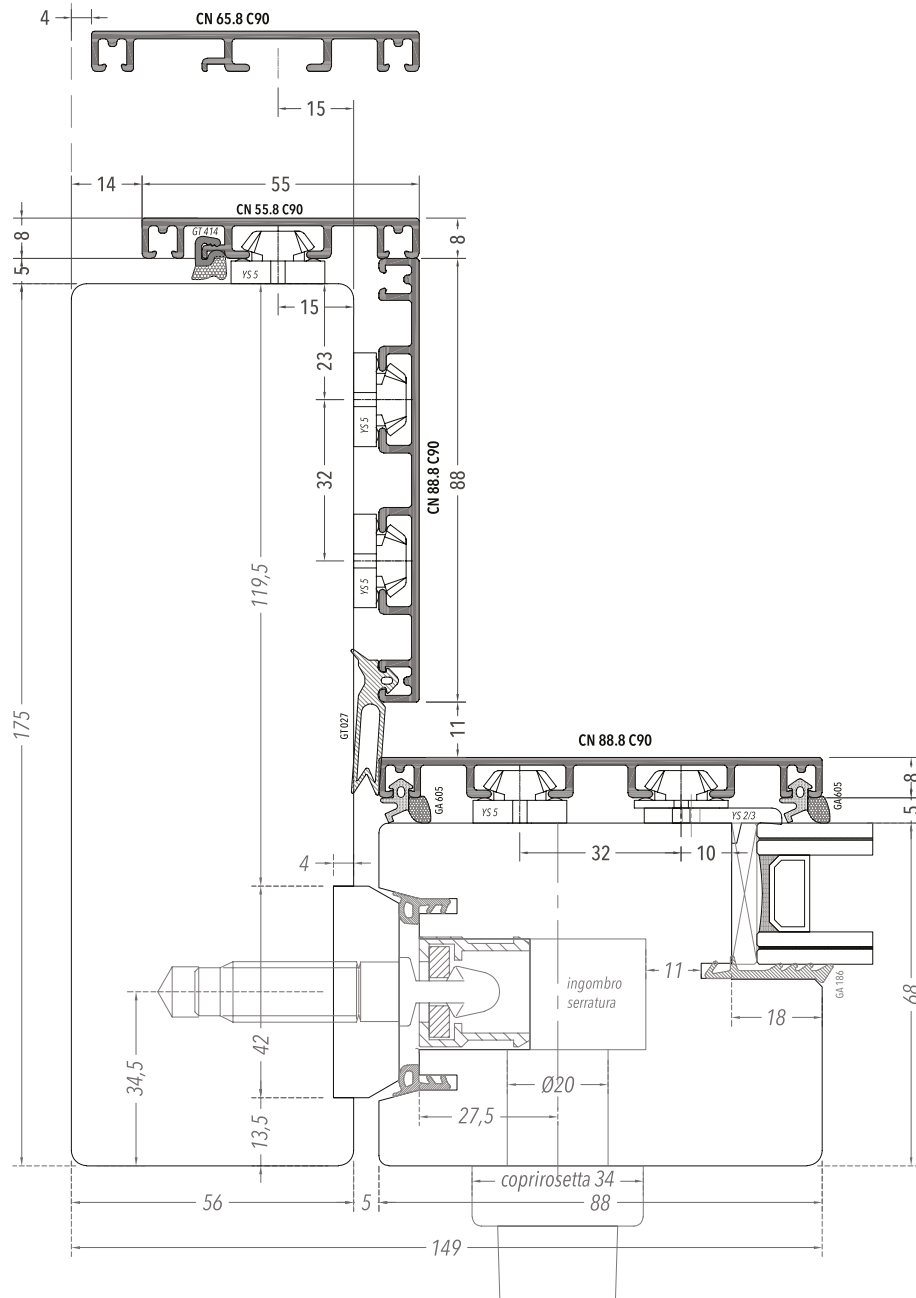
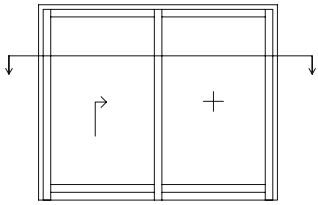

Variante con profilo di rivestimento  
CN 72.8 C90 (anta in legno da 74 mm)



Variante con profilo di rivestimento  
CN 100.8 C90 (anta in legno da 100 mm)



Variante con profilo di rivestimento  
CN 110.8 C90 (anta in legno da 110 mm)

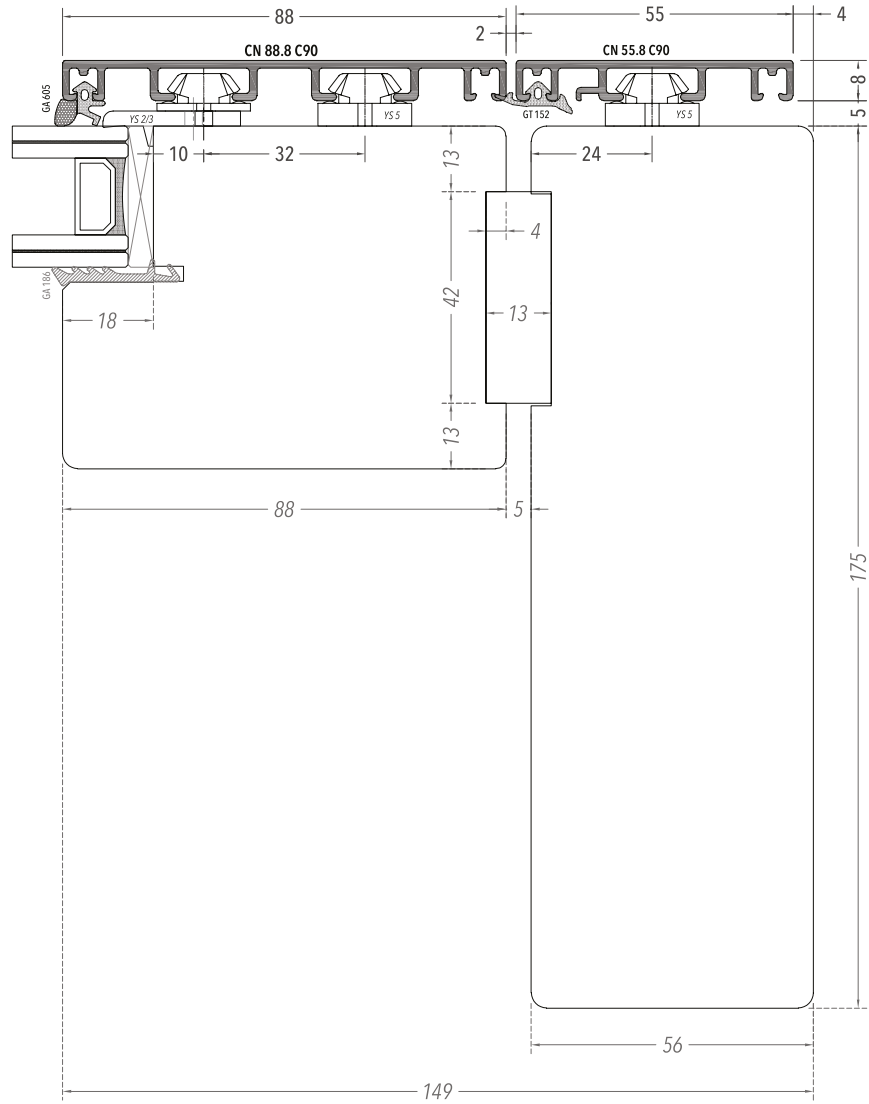
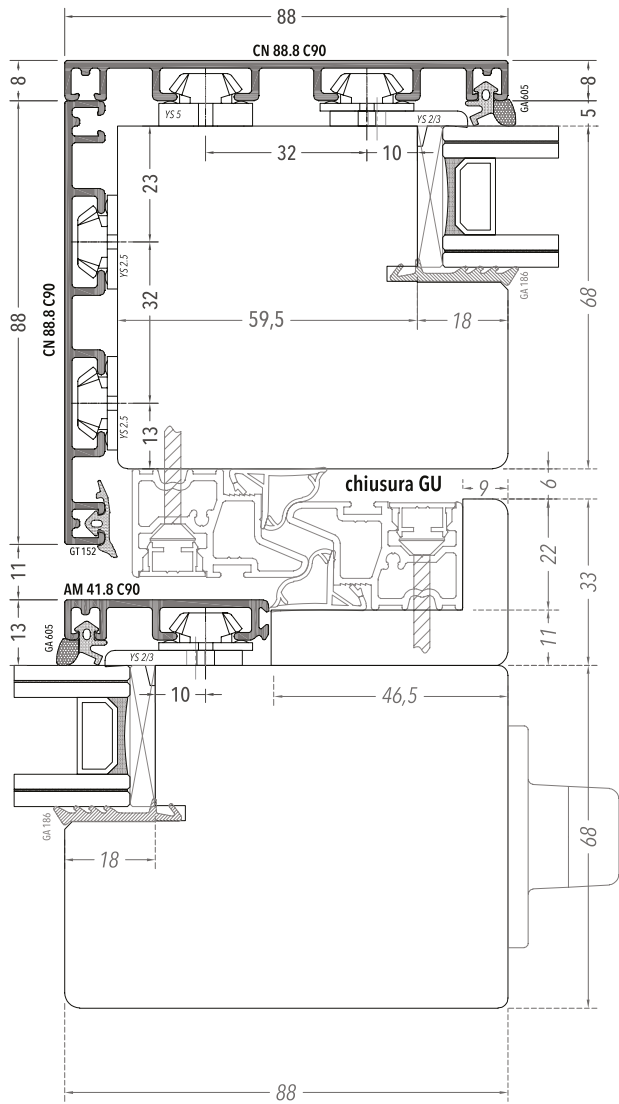





SEZIONE VERTICALE  
SCALA 1:1.5

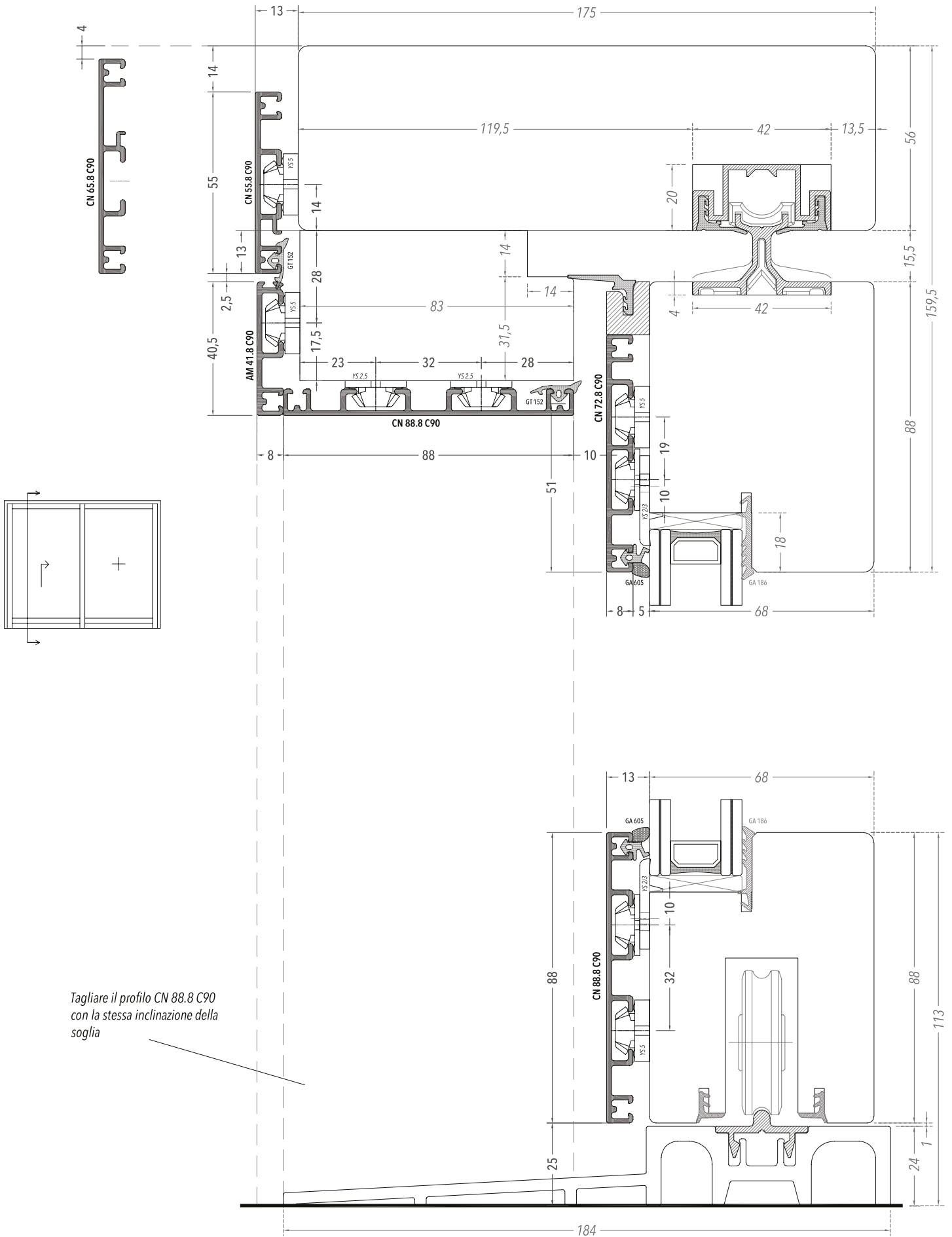



# Alzanti scorrevoli

---

GU DOPPIA ANTA  
SCORREVOLE

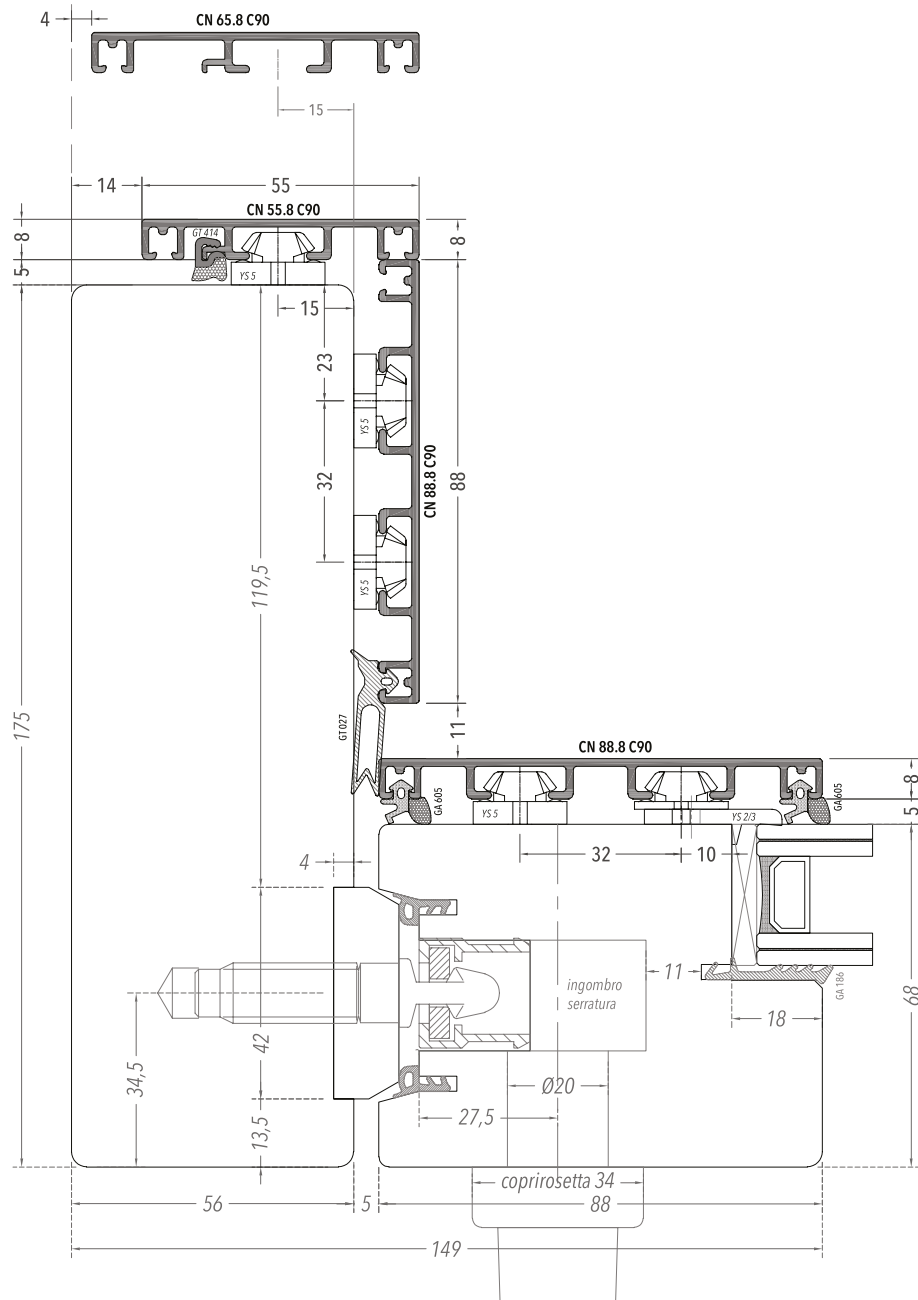
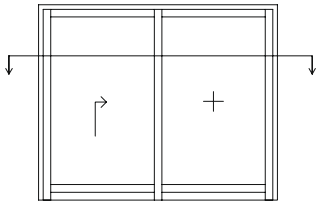

Variante con profilo di rivestimento  
CN 72.8 C90 (anta in legno da 74 mm)

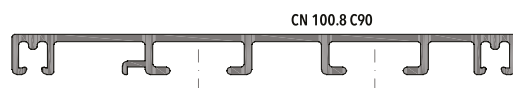

Variante con profilo di rivestimento  
CN 100.8 C90 (anta in legno da 100 mm)

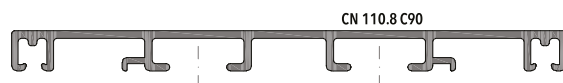

Variante con profilo di rivestimento  
CN 110.8 C90 (anta in legno da 110 mm)

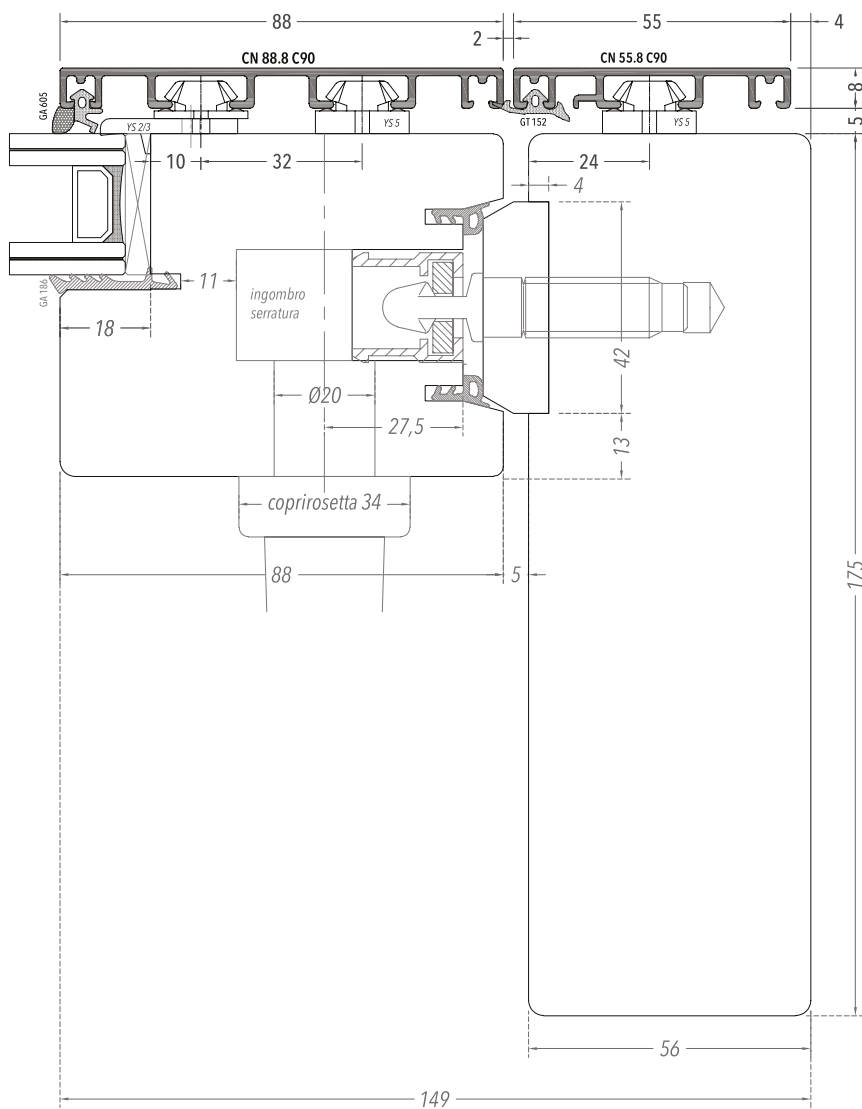
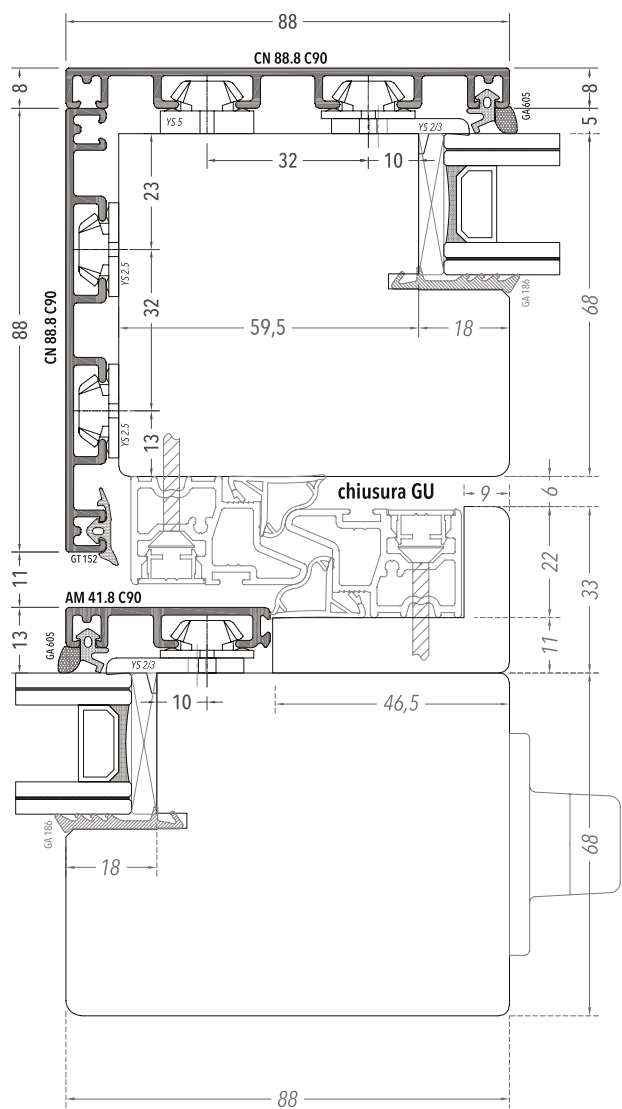

SEZIONE VERTICALE  
SCALA 1:1.5

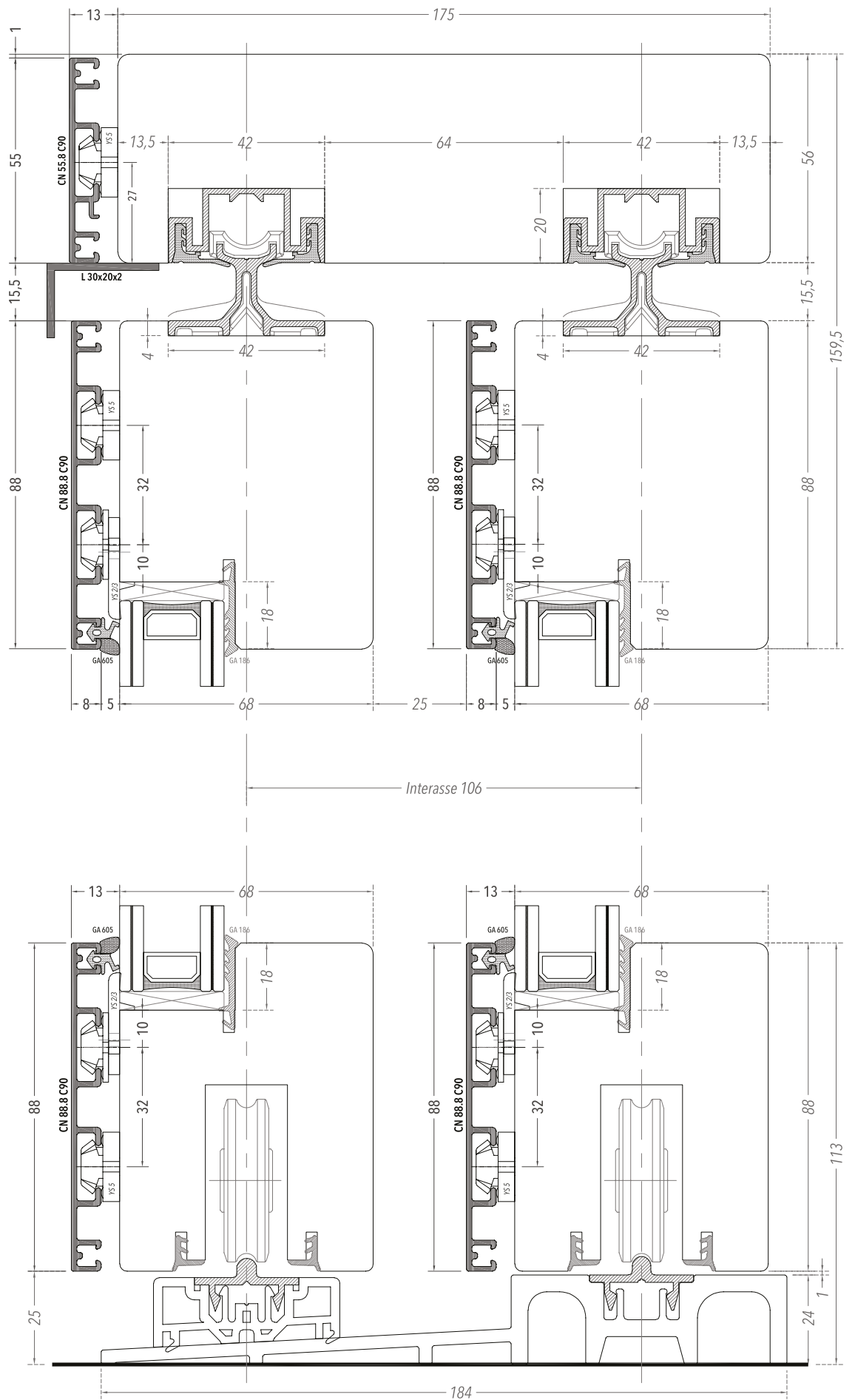
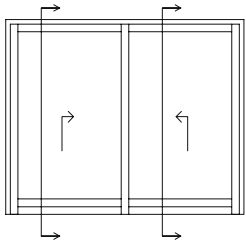

# Alzanti scorrevoli

---

GU GRAN LUCE

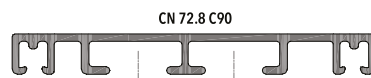
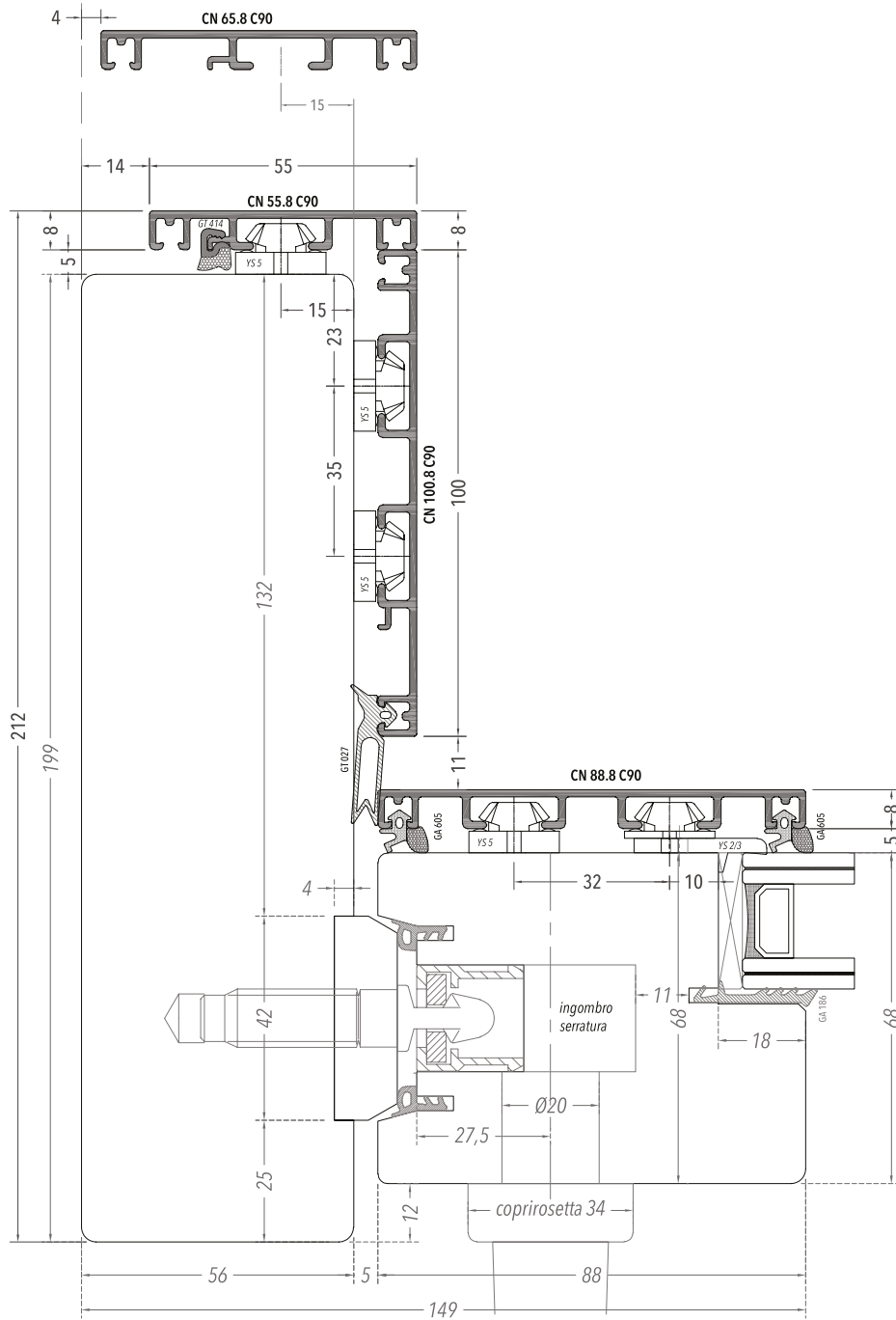
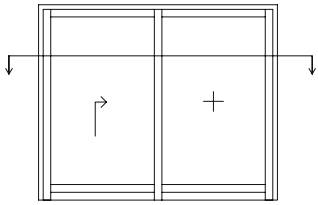

Variante con profilo di rivestimento  
CN 72.8 C90 (anta in legno da 74 mm)

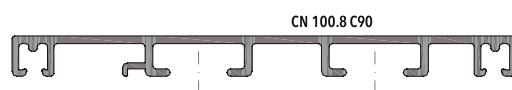

Variante con profilo di rivestimento  
CN 100.8 C90 (anta in legno da 100 mm)



Variante con profilo di rivestimento  
CN 110.8 C90 (anta in legno da 110 mm)



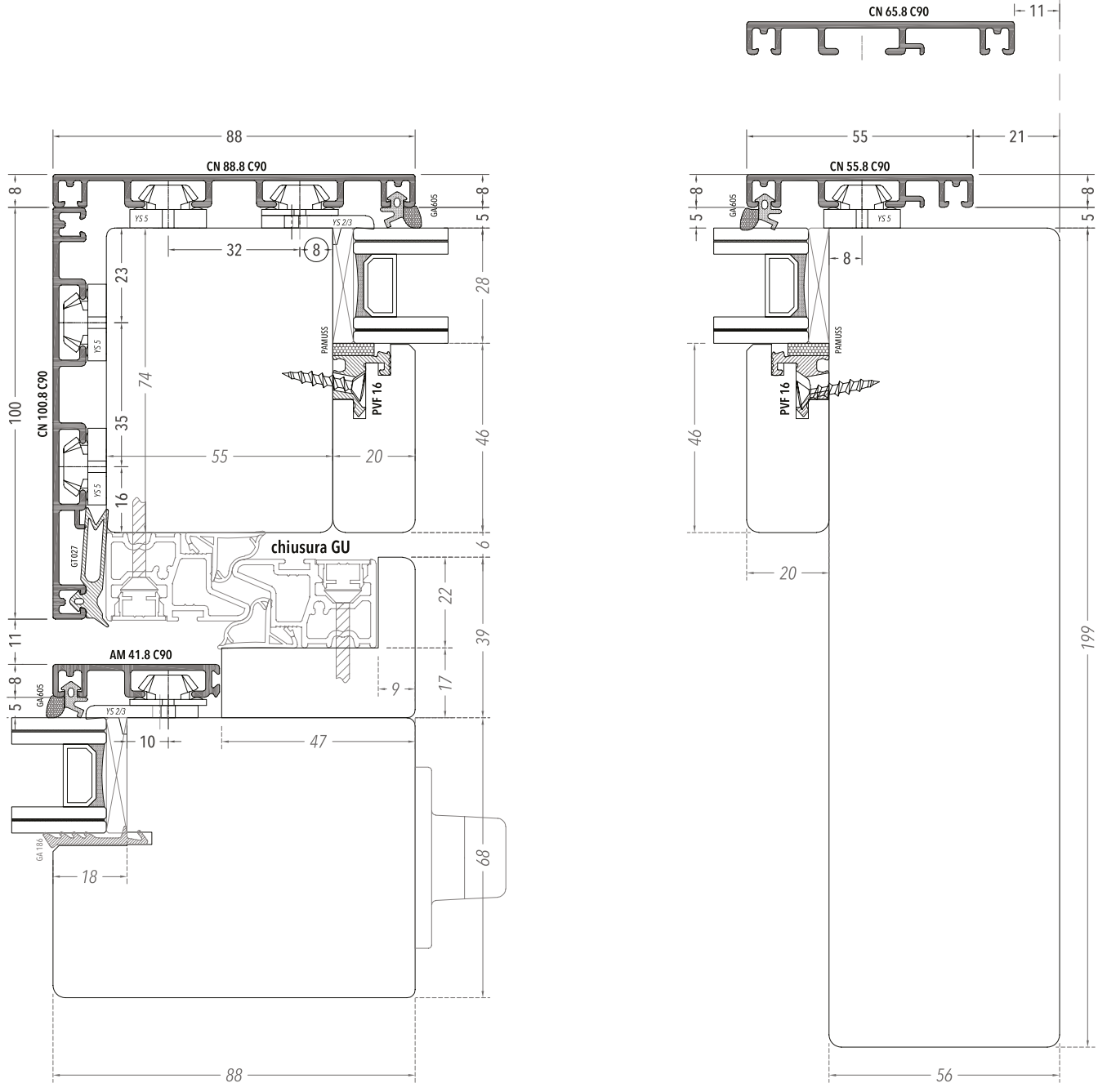

SEZIONE VERTICALE  
SCALA 1:1.5

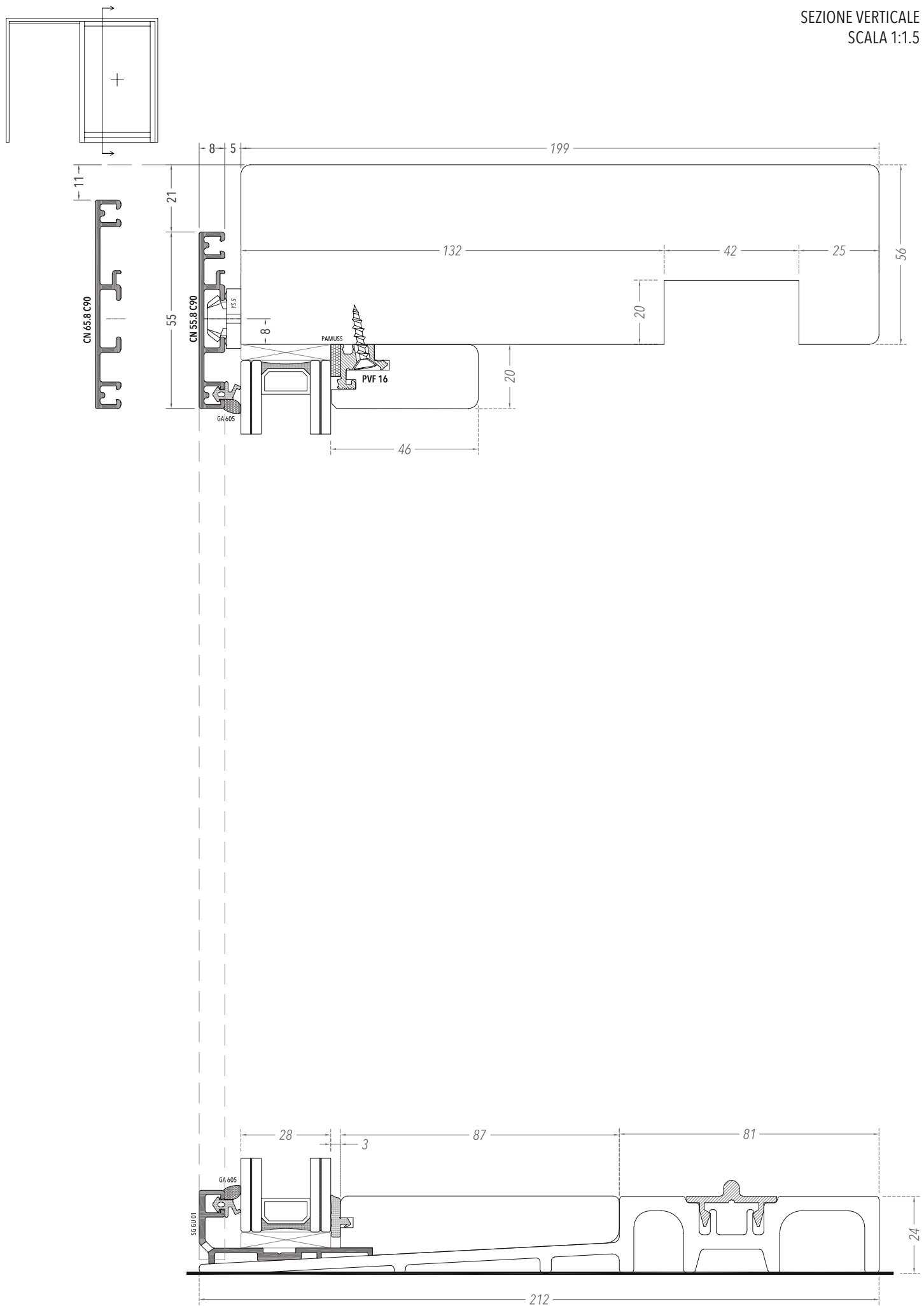

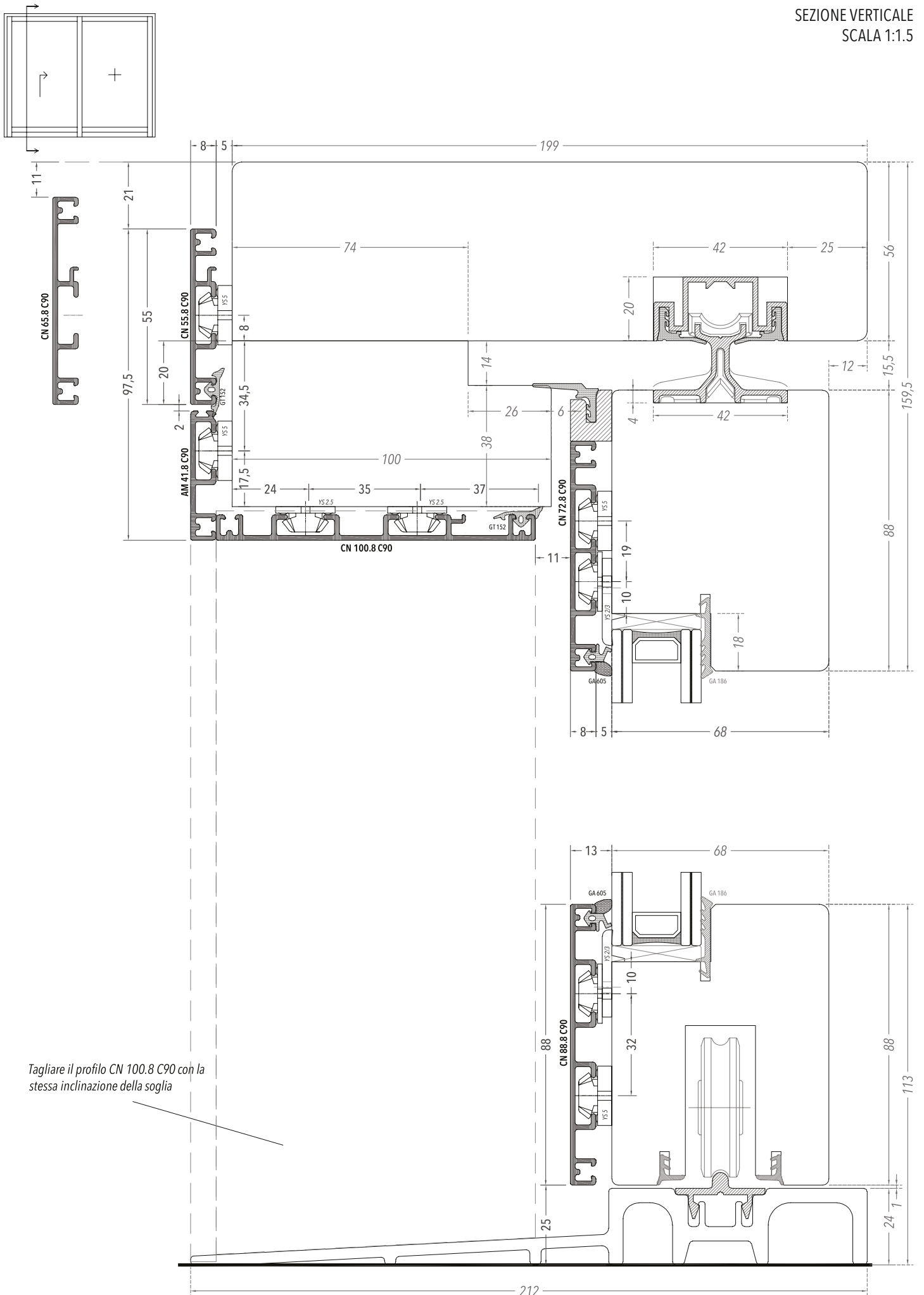

Tagliare il profilo CN 100.8 C90 con la stessa inclinazione della soglia



### **COVERFAST: PERFORMANCE, STILE, QUALITÀ**

Coverfast è la linea di portoni Alumframe pensata per garantire sicurezza e protezione, capace di adattarsi a qualsiasi ambiente in cui viene inserita.

Applicabile facilmente al sistema Alumfast desiderato (Sistema 21, Sistema 16, Sistema 16 Eco e Easy) e disponibile nelle finiture RAL e speciali, Coverfast offre una vasta gamma di soluzioni dal design accattivante, per un connubio perfetto tra stile, qualità e alte prestazioni.

# Coverfast

---

LINEA PORTONI



Mod. 01 \*



\* Mod. 02



\* Mod. 03



\* Mod. 04



\* Mod. 05

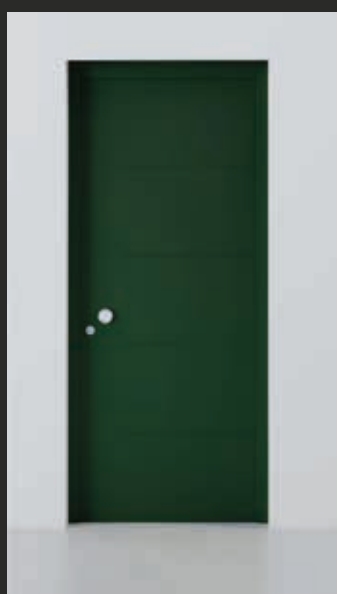

\* Mod. 06



\* Mod. 07

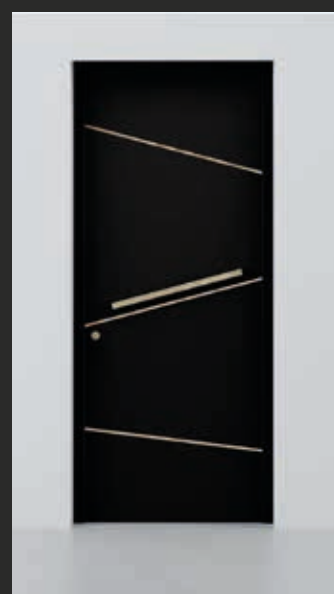

\* Mod. 08

Tutti i modelli sono disponibili nelle finiture RAL e speciali.  
\* La finitura in decorato legno è applicabile solo al Mod. 01.



★ Mod. 09



● Mod. 10

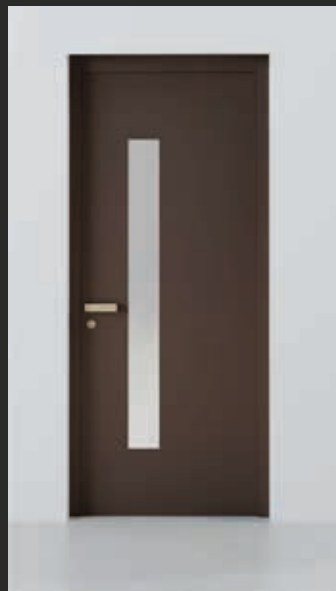

● Mod. 11



● Mod. 12

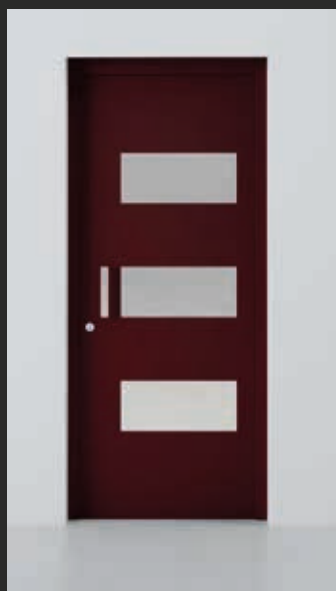

● Mod. 13

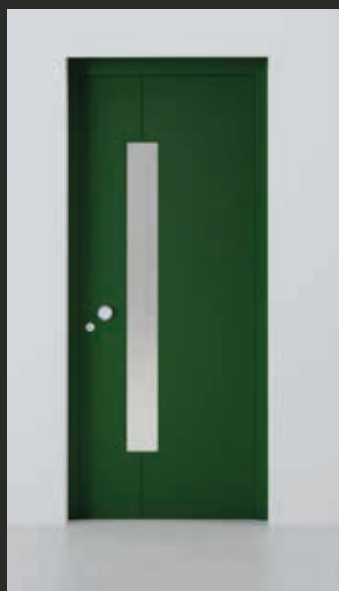

● ◆ Mod. 14



● ◆ Mod. 15



● ◆ Mod. 16

★ Modelli con incisioni e inserti

● Modelli con vetro

◆ Modelli con bassofondo

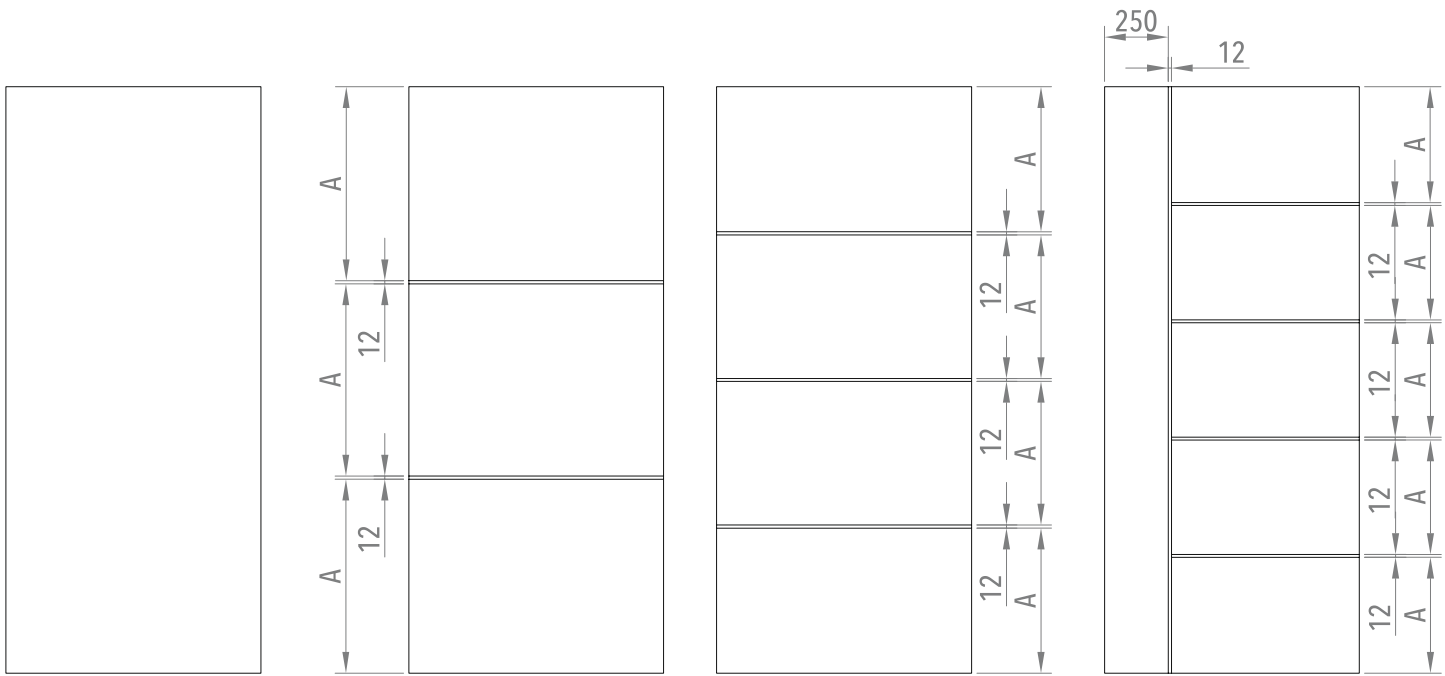

Mod. 01 \*

Mod. 02

Mod. 03

Mod. 04

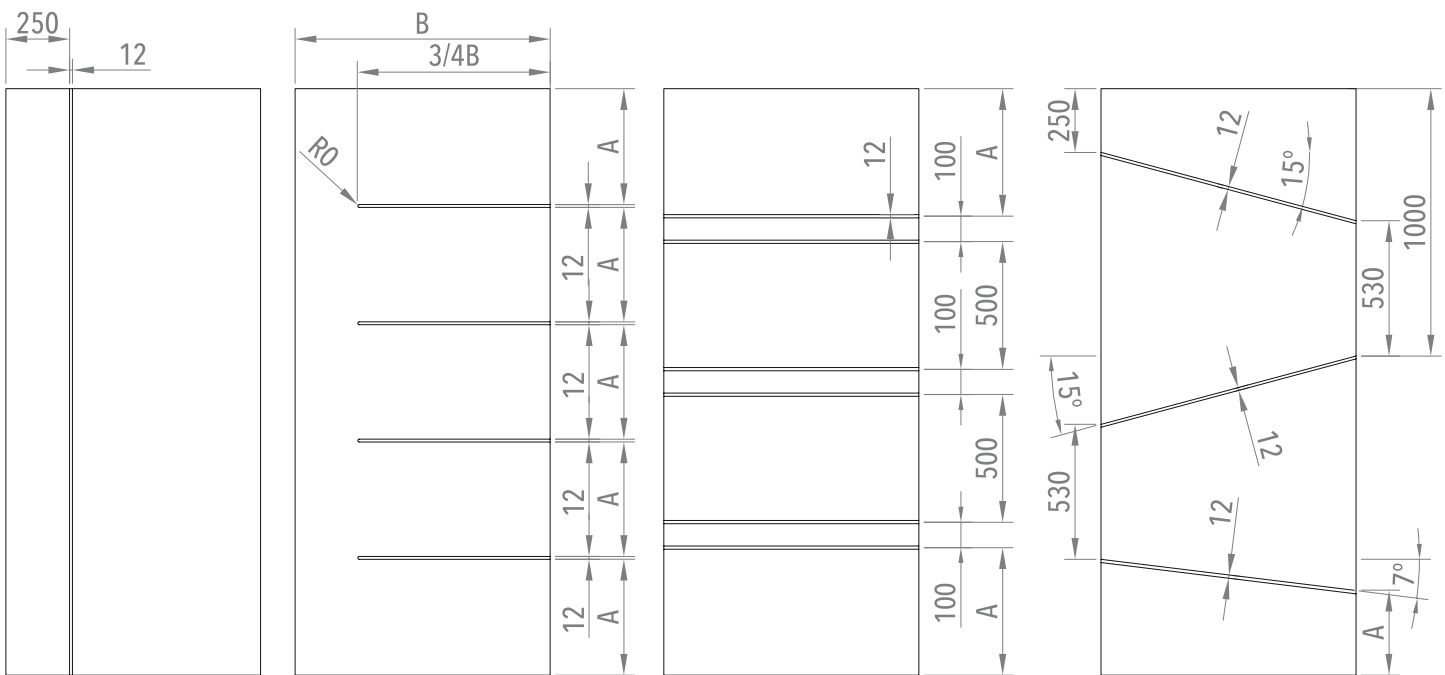

Mod. 05

Mod. 06

Mod. 07

Mod. 08

Tutti i modelli sono disponibili nelle finiture RAL e speciali.  
 \* La finitura in decorato legno è applicabile solo al Mod. 01.



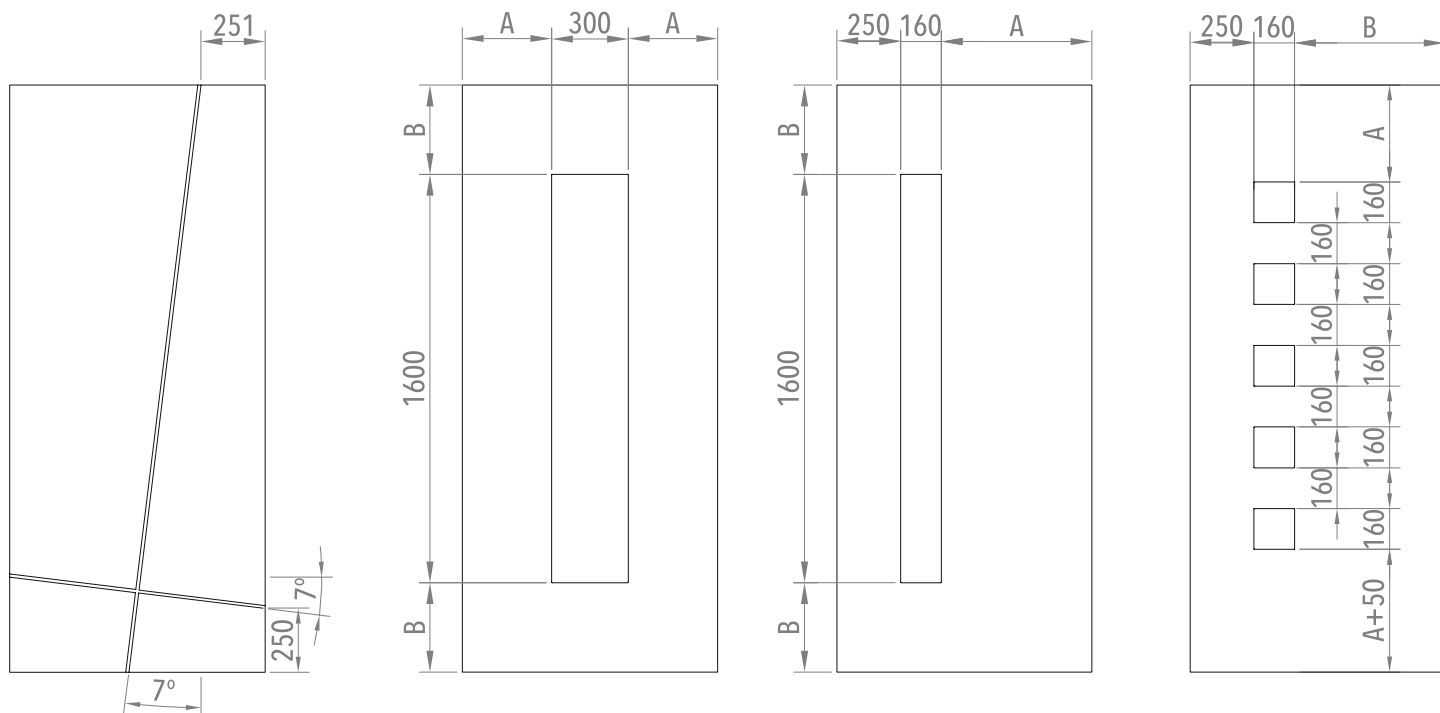

Mod. 09

Mod. 10

Mod. 11

Mod. 12

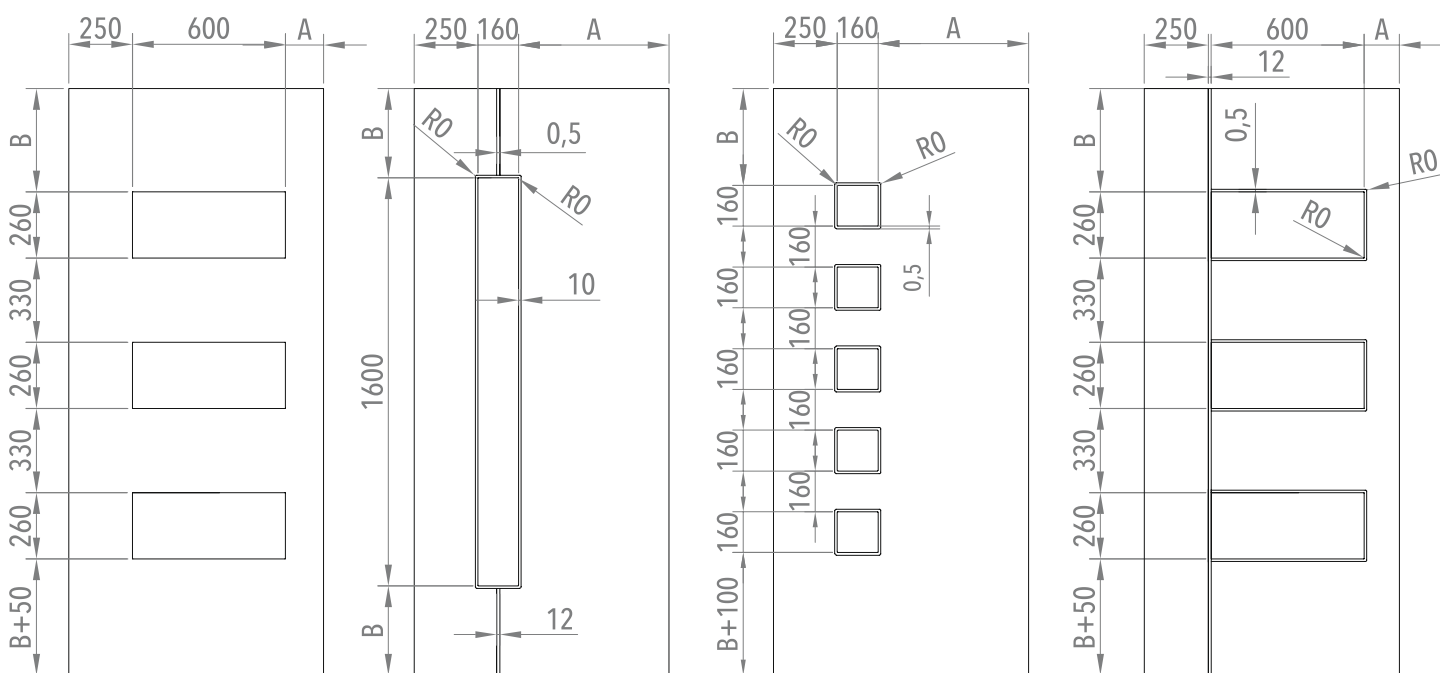

Mod. 13

Mod. 14

Mod. 15

Mod. 16

Tutti i modelli sono disponibili nelle finiture RAL e speciali.

# Coverfast

---

SISTEMA 21

SISTEMA 16

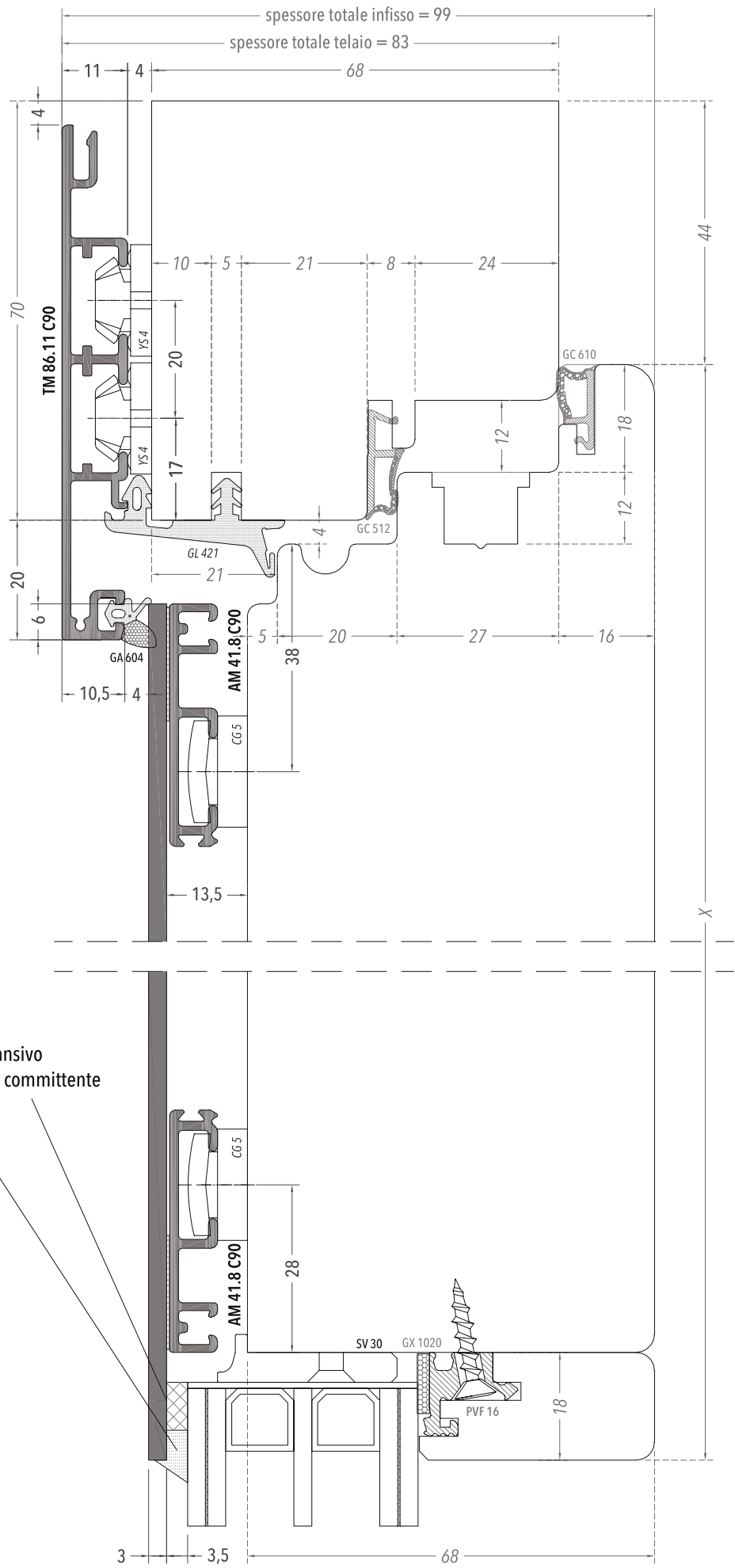
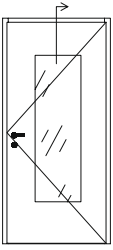

Nastro espansivo  
a carico del committente

Applicazione di silicone  
successiva al montaggio vetro

Variante con bassofondo  
in prossimità del vetro

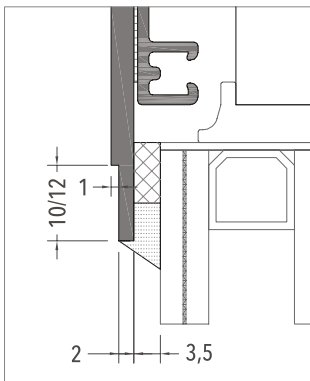

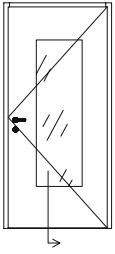

Nastro espansivo a carico del committente  
 Applicazione di silicone successiva al montaggio vetro

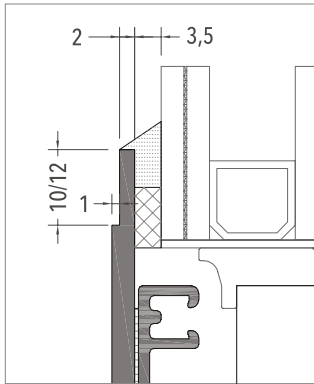

Variante con bassofondo in prossimità del vetro

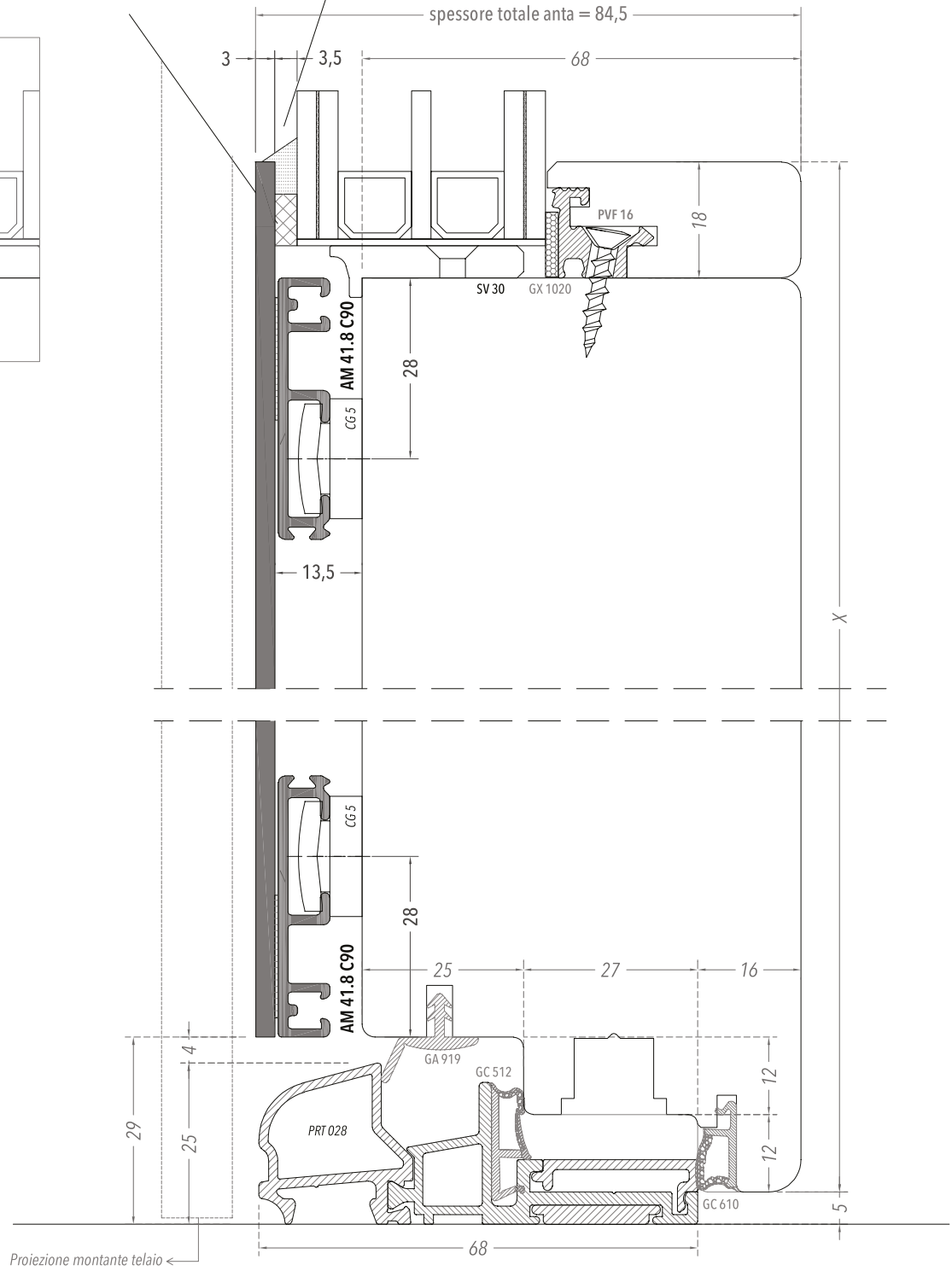

RUOTA  
PAGINA

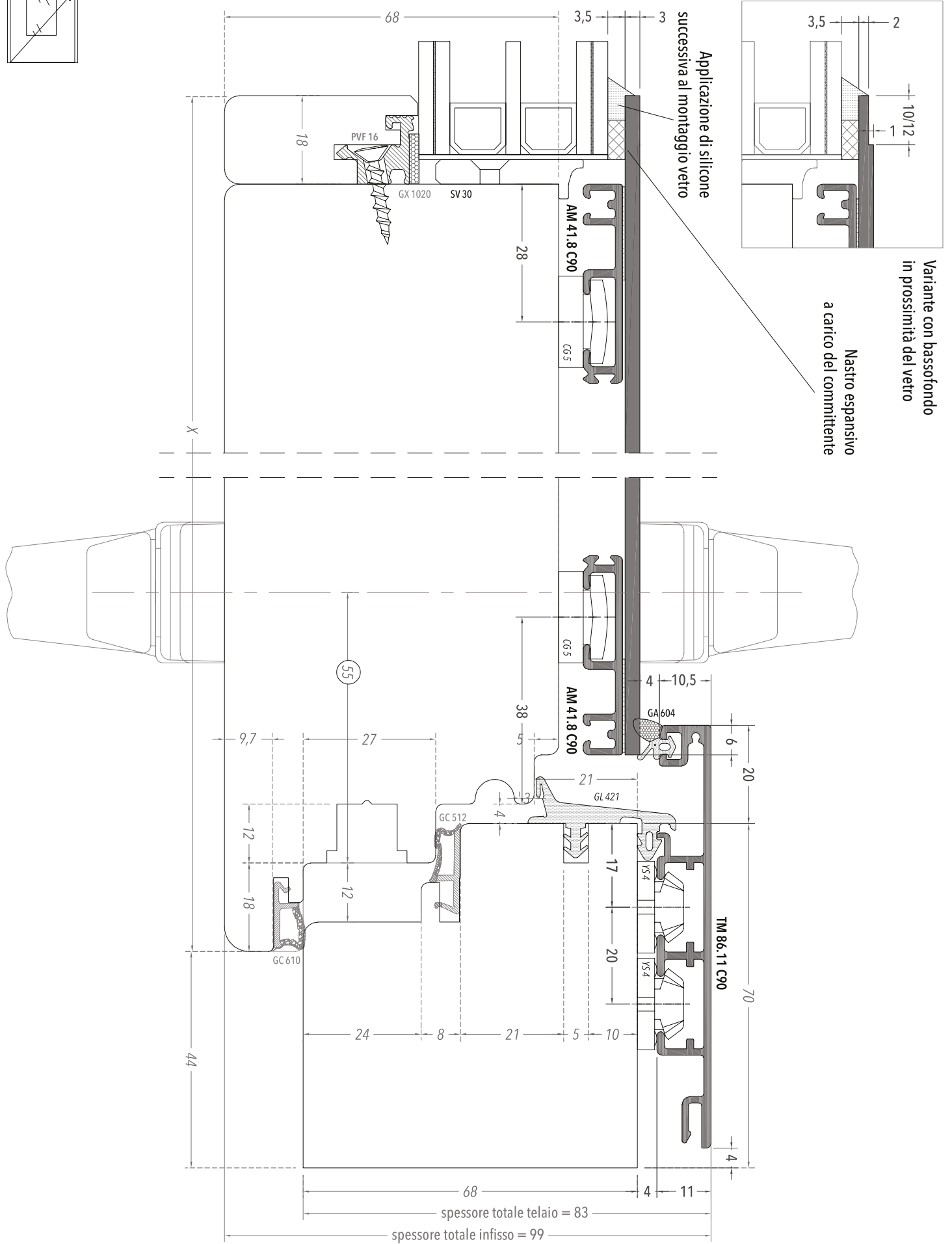
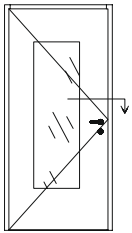

# Coverfast

---

SISTEMA 16 ECO

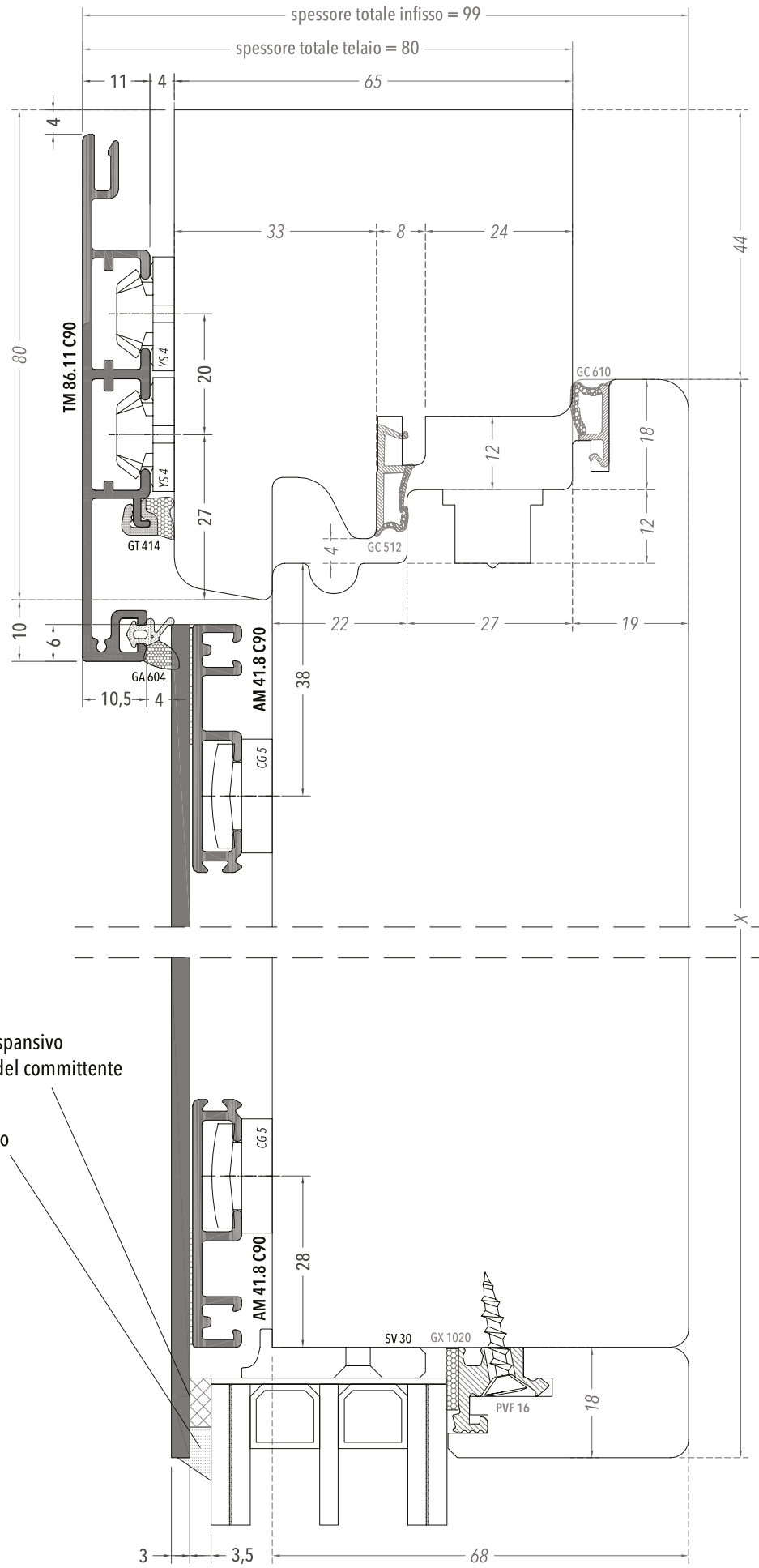
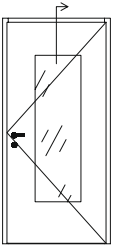

Nastro espansivo a carico del committente

Applicazione di silicone successiva al montaggio vetro

Variante con bassofondo in prossimità del vetro

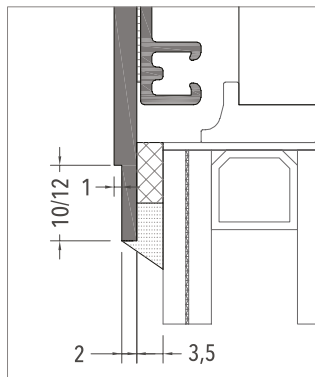

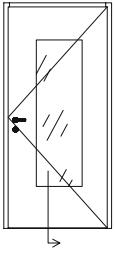

Nastro espansivo a carico del committente

Applicazione di silicone successiva al montaggio vetro

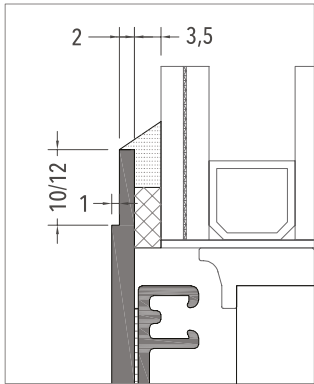

Variante con bassofondo in prossimità del vetro

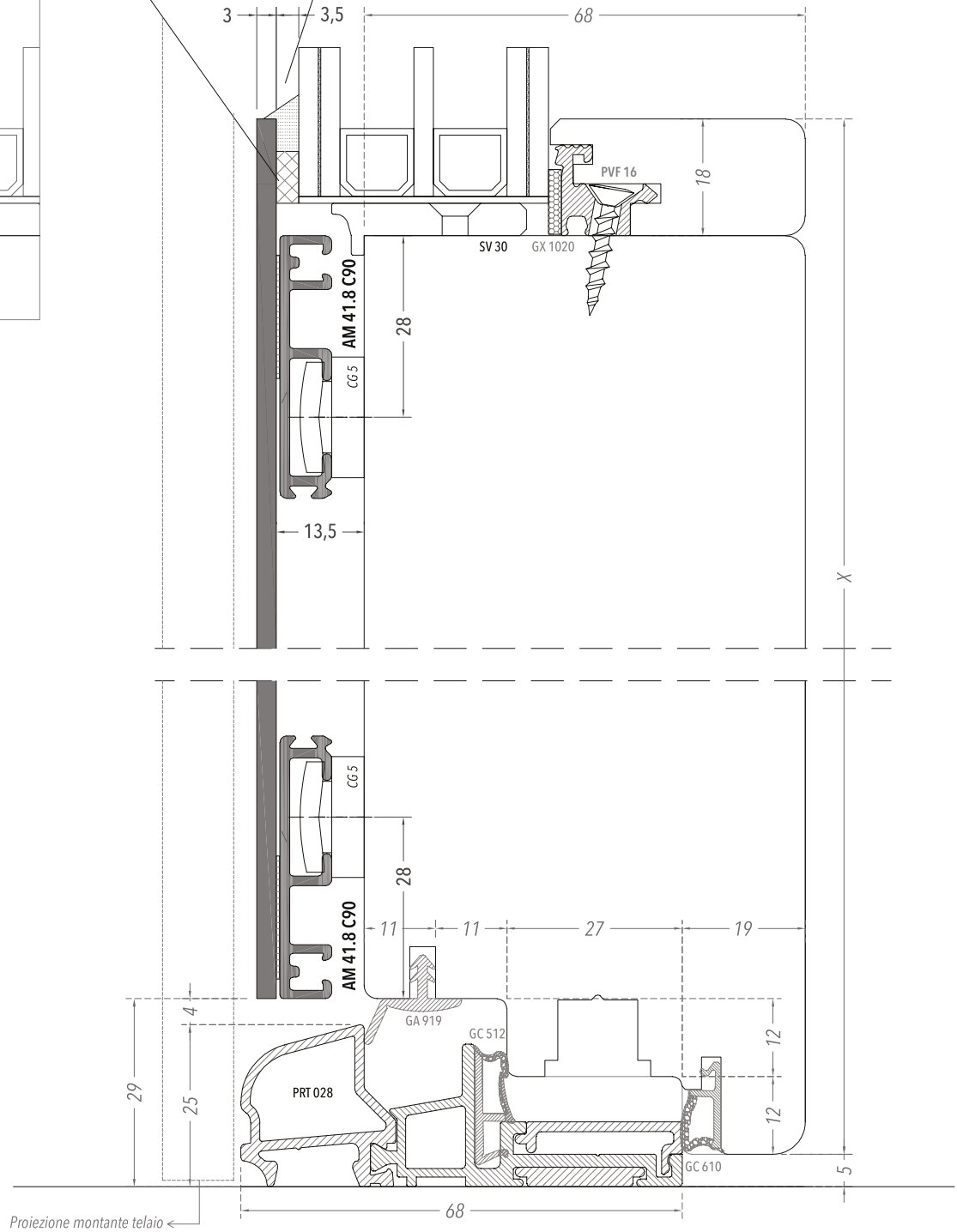



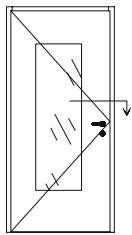

RUOTA  
PAGINA

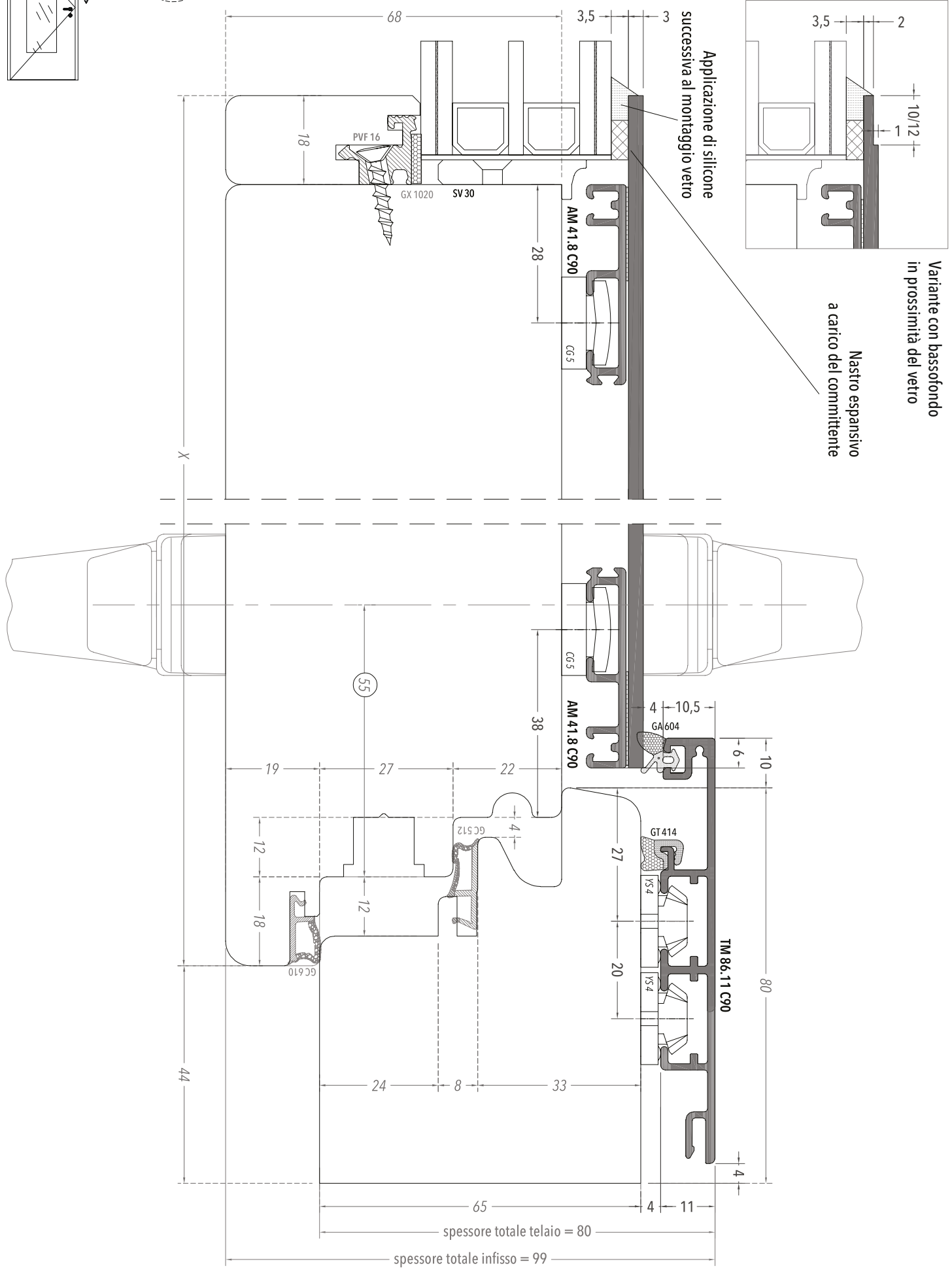

# Coverfast

---

EASY

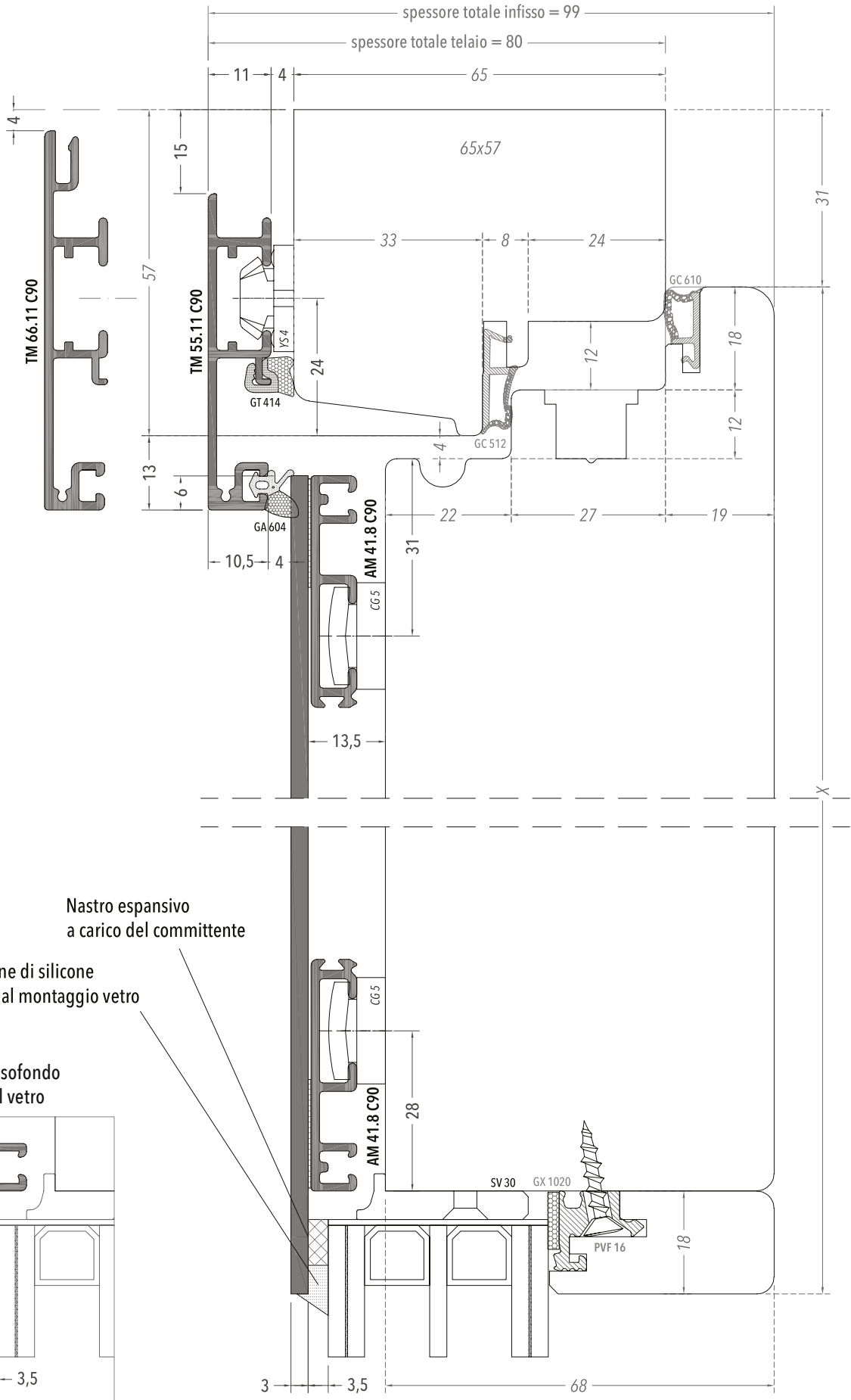
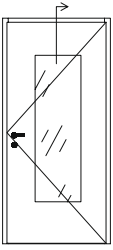

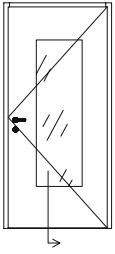

Nastro espansivo a carico del committente

Applicazione di silicone successiva al montaggio vetro

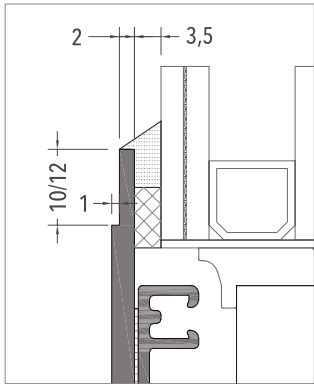

Variante con bassofondo in prossimità del vetro

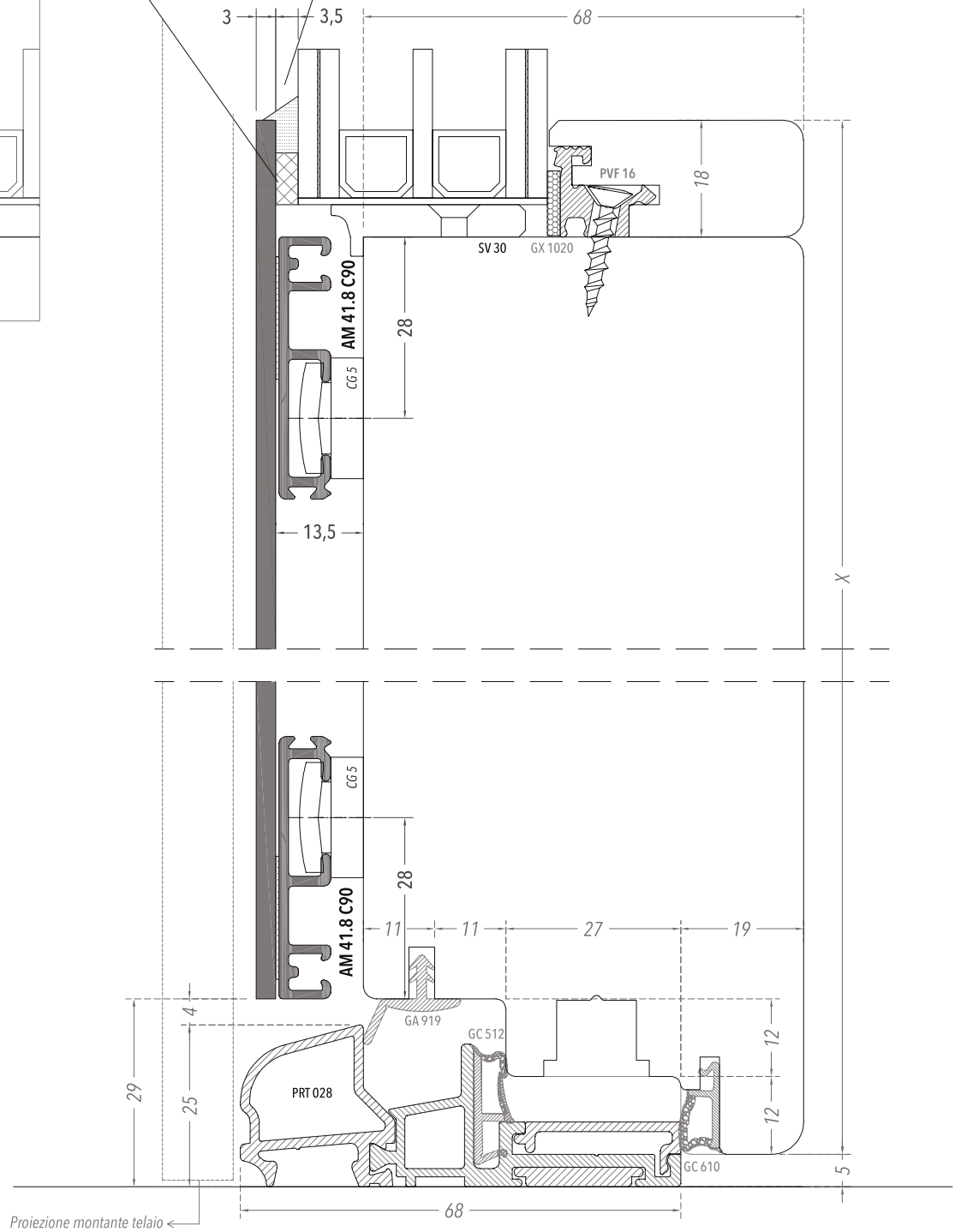

RUOTA PAGINA

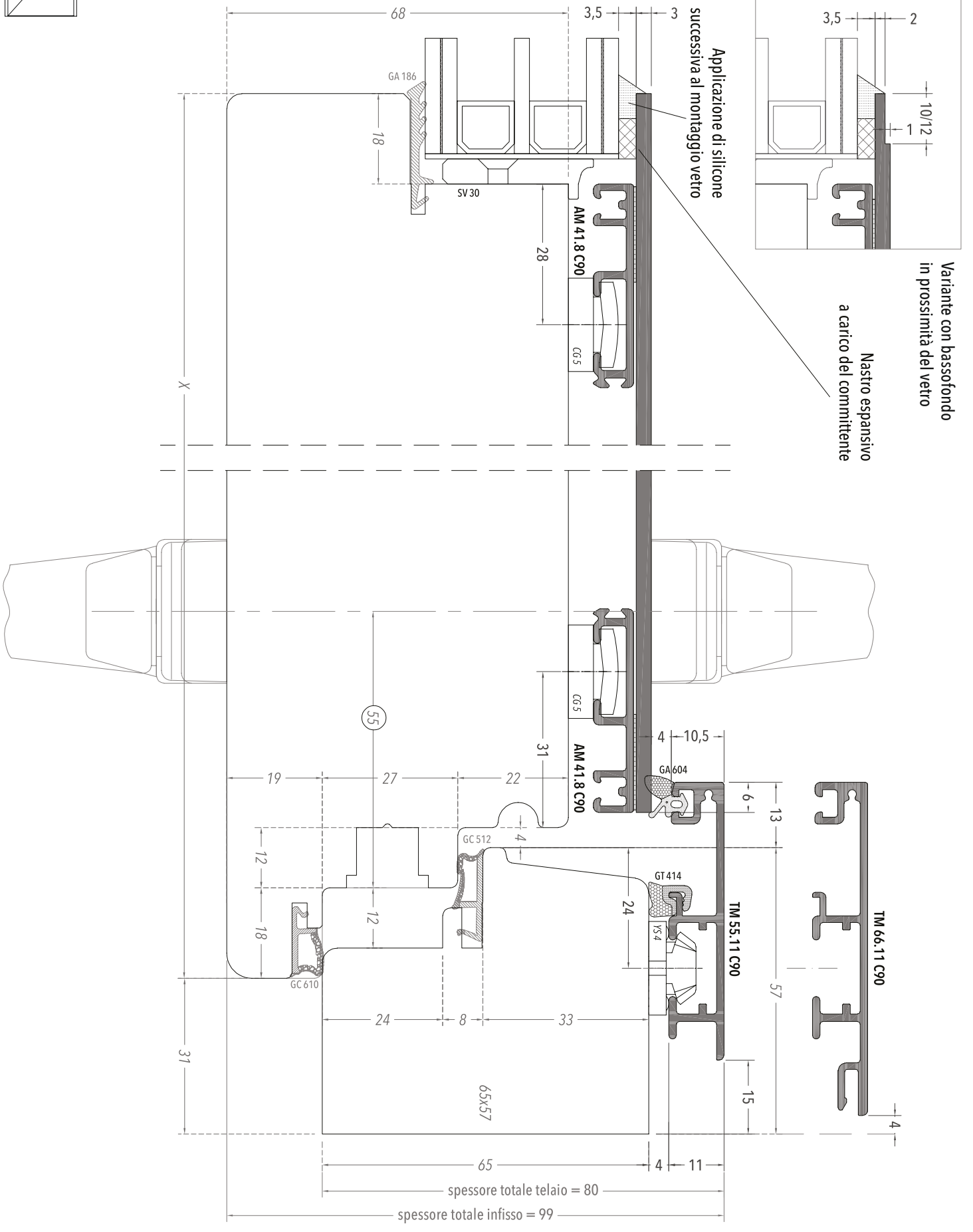
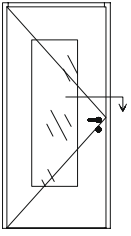



# Riepilogo

---

PROFILI,  
ACCESSORI,  
FINITURE

AM 31.8 C90

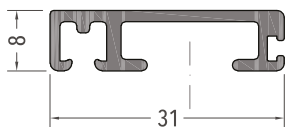

AM 41.8 C90

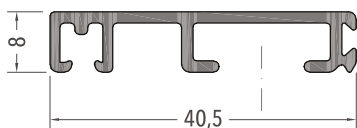

AM 41.15 C90

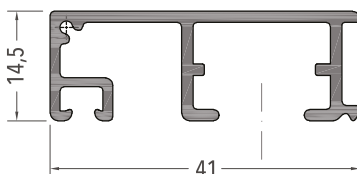

AM 41.8/18 C90

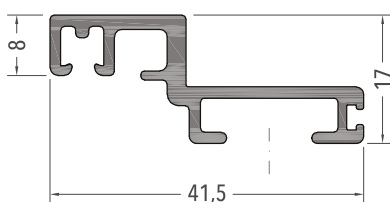

AM 41.8/24 C90

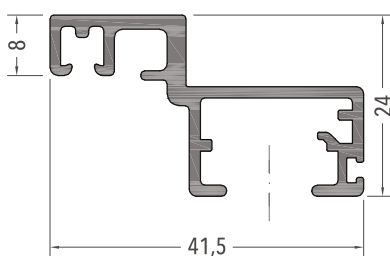

AM 41.17 C90

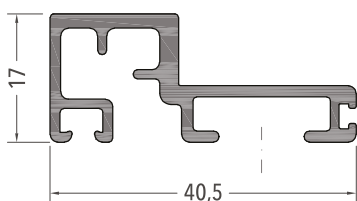

AM 72.15 C90

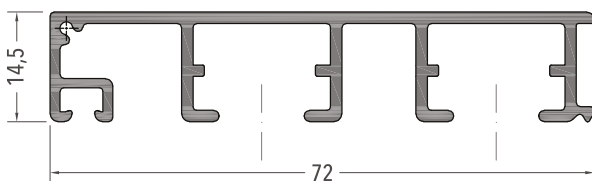

AM 76.8/18 C90

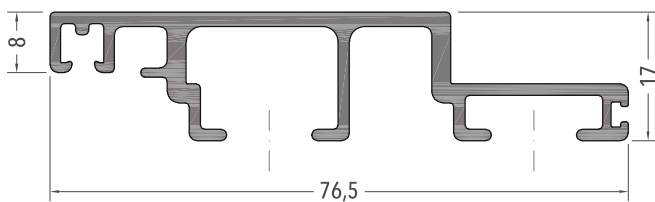

AM 72.8/24 C90

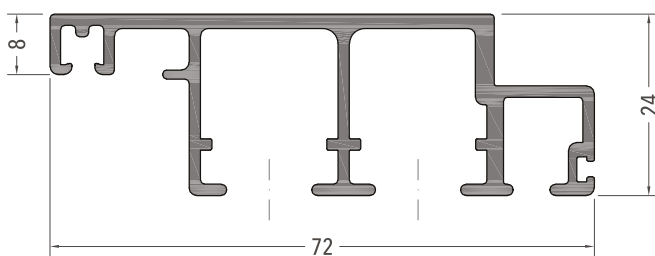



AM 41.15 C15

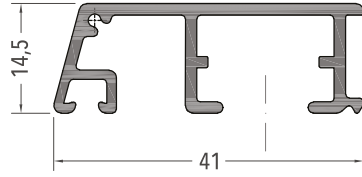

AM 41.17 C15

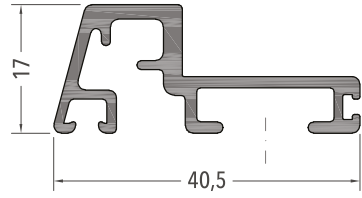

AM 41.24 C15

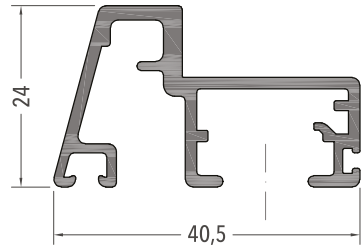

AM 72.15 C15

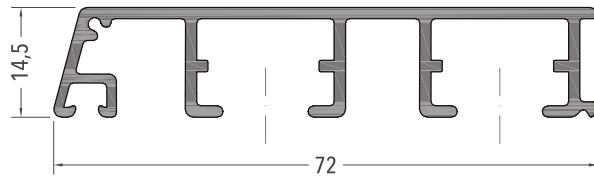

AM 72.24 C15

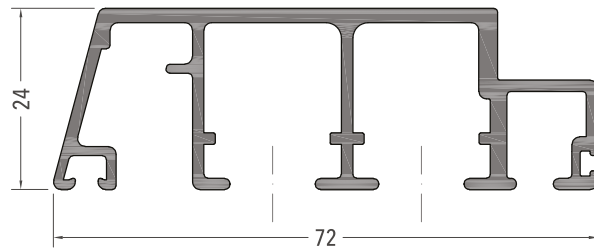

AT 31.7 C90

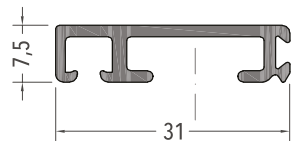

AT 41.7 C90

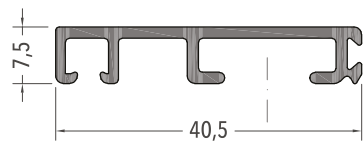

AT 41.14 C90

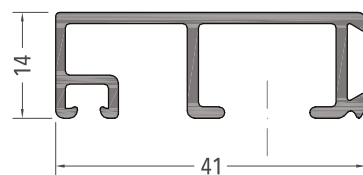

AT 41.7/18 C90

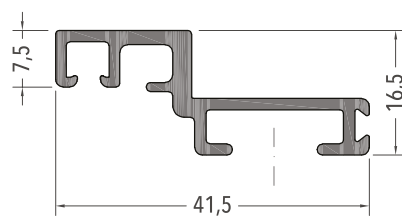

AT 41.7/23 C90

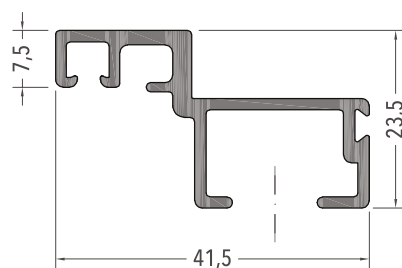

AT 41.16 C90

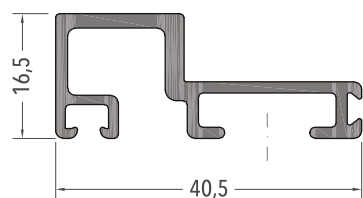

AT 72.14 C90

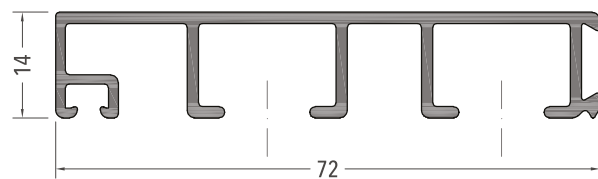

AT 76.7/18 C90

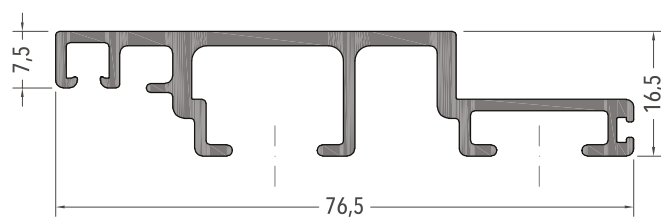

AT 72.7/23 C90

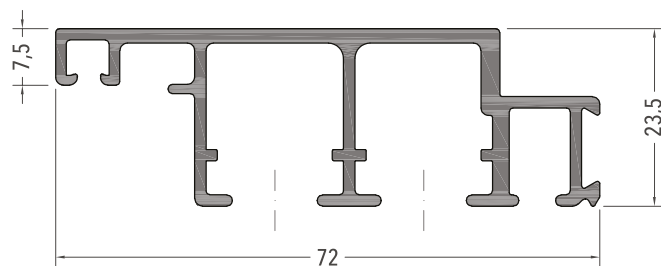

AT 41.14 C15

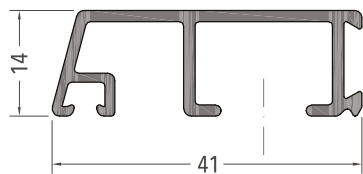

AT 41.16 C15

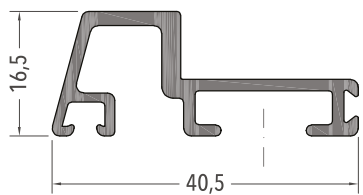

AT 41.23 C15

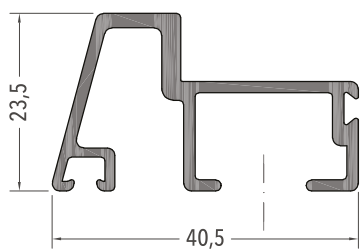

AT 72.14 C15

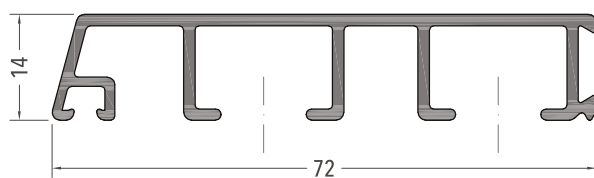

AT 72.23 C15

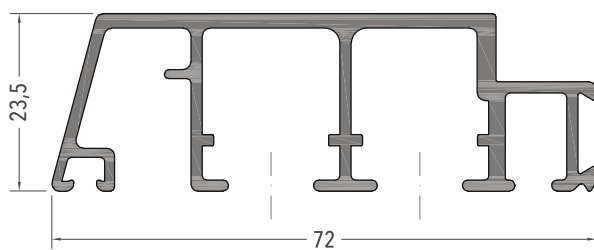

TM 55.11 C90

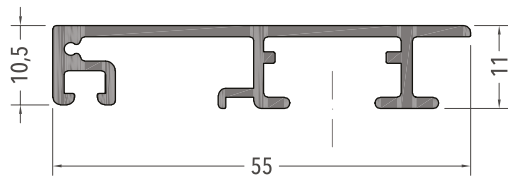

TM 66.11 C90

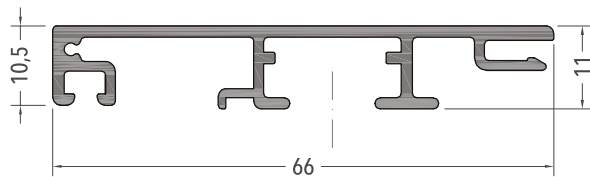

TM 76.11 C90

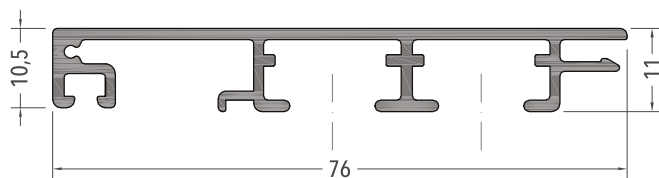

TM 86.11 C90

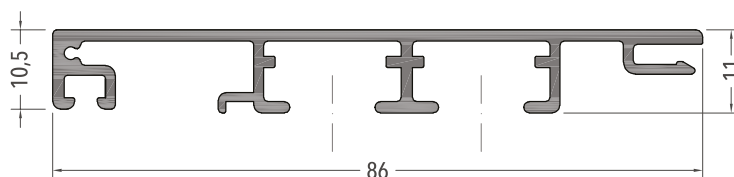

BD 77.8 C90

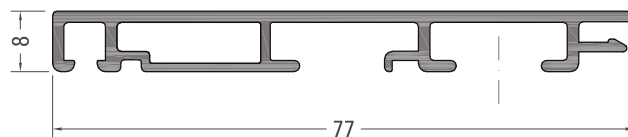

BD 85.8 C90

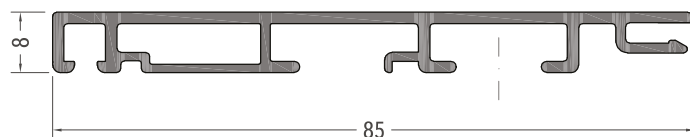

TO 68.8 C90

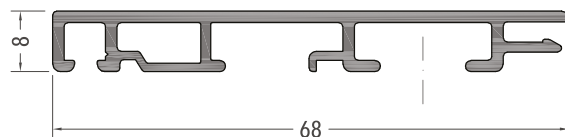

TO 78.8 C90

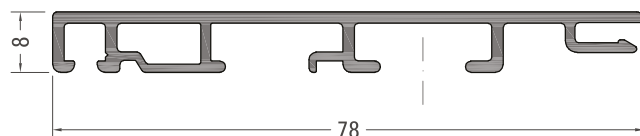

TO 98.8 C90

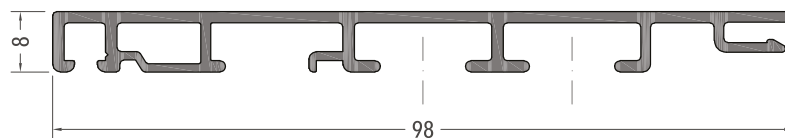

TM 65.7/16 C90

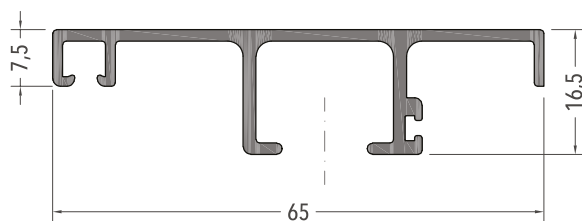

TM 77.17 C90

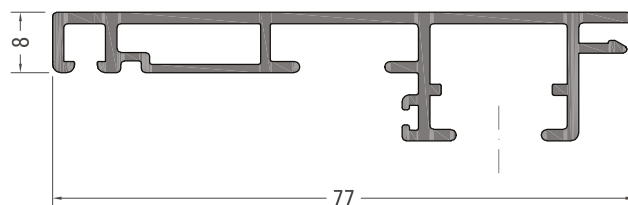

TM 56.11 C15

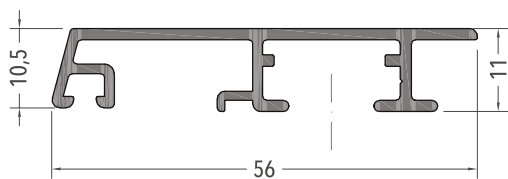

TM 66.11 C15

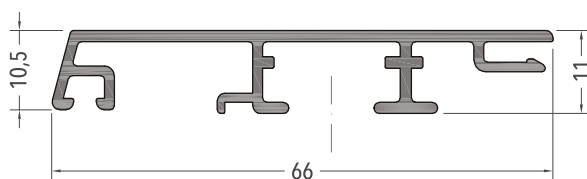

TM 76.11 C15

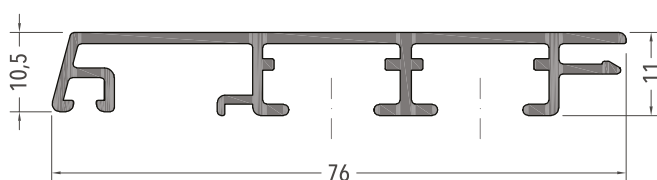

TM 86.11 C15

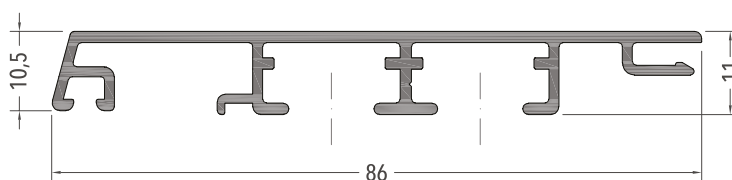

AT 38.7/6 C90

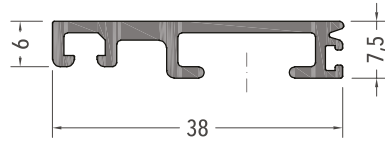

AT 38.7 LU

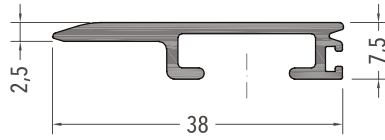

TL 37.6 LU

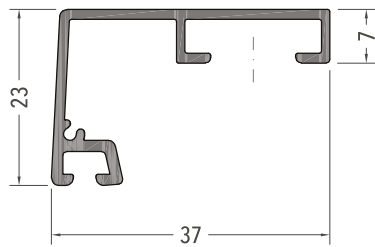

TL 86.6 LU

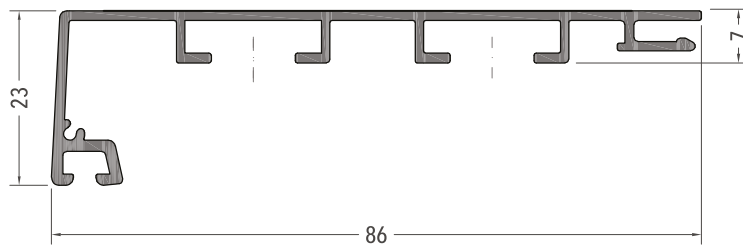

**CN 66.11 LU**

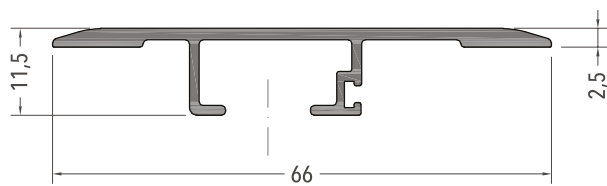

**CN 66.25/9 LU**

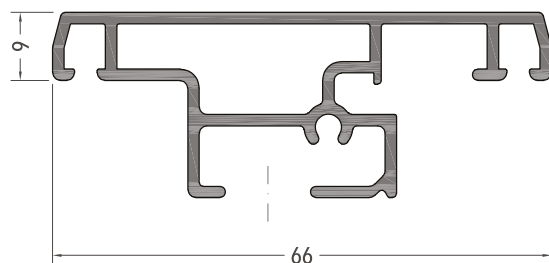

**CN 72.2/18 C90**

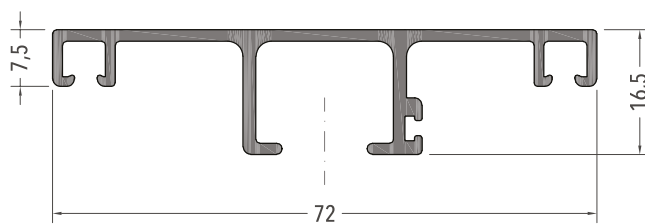

CN 55.8 C90

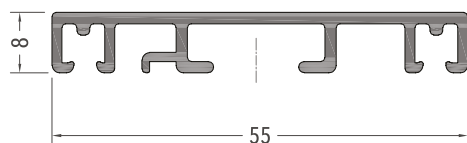

CN 65.8 C90

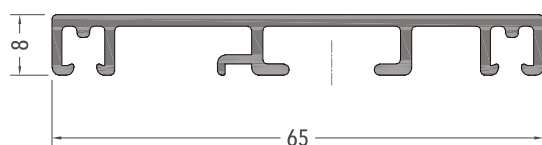

CN 72.8 C90

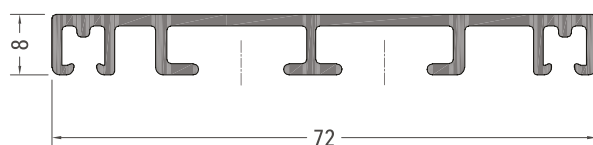

CN 82.8 C90

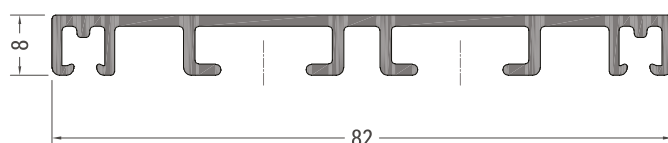

CN 88.8 C90

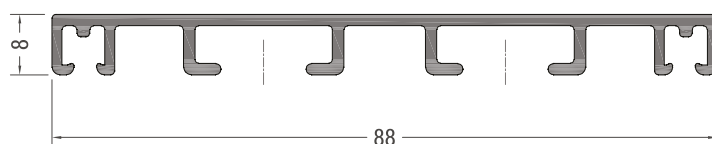

CN 100.8 C90

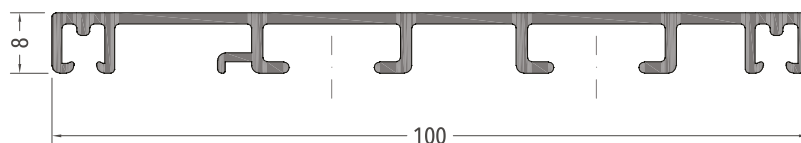

CN 110.8 C90

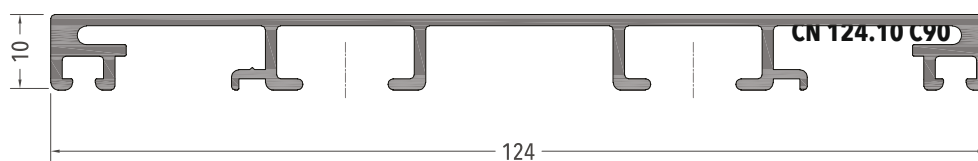
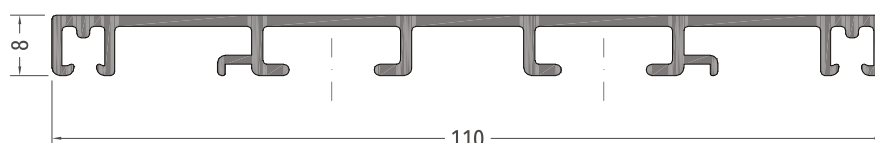

CT 120.10 C90

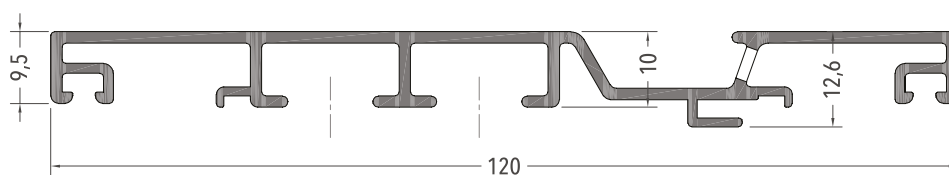

CN 120.10 C15

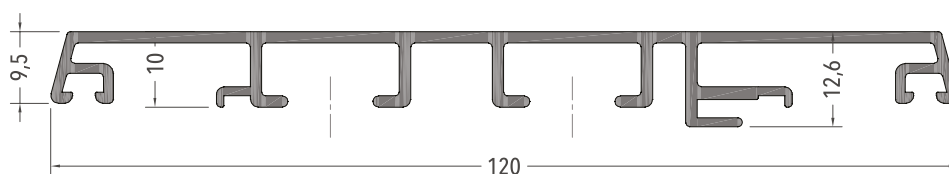



AMZ 19.8 C90

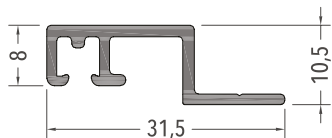

SG AGB 01

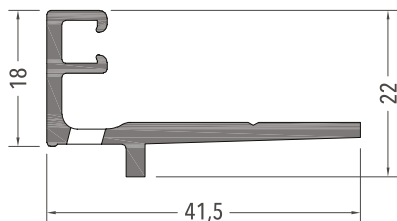

SG GU 01

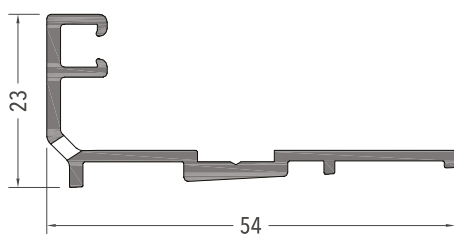

AS 50.3

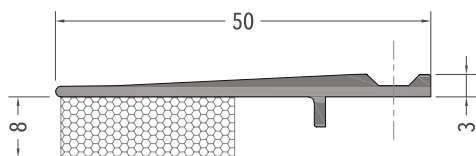

LF 27.10

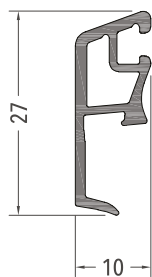

KT 01

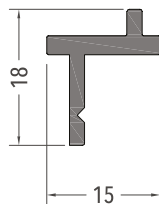

GOCCIOLATOIO

GUIDA AVVOLGIBILE

PROFILI

TG 35.13

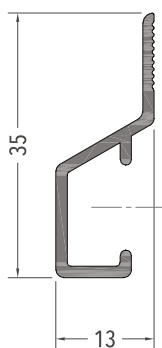

AV 42.35

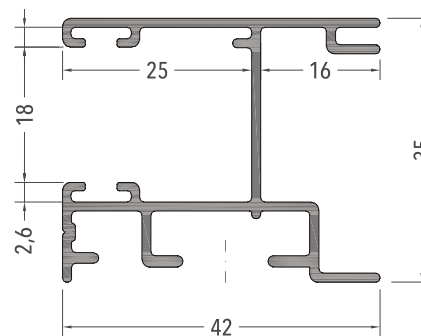

**PFV 1214**  
Listello da 15

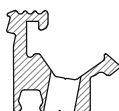

**PFV 1614**  
Listello da 18



**SBP 20x2**

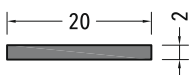

**SBP 30x2**

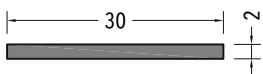

**SBP 40x2**

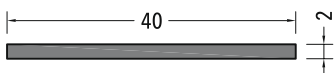

**SBP 50x2**

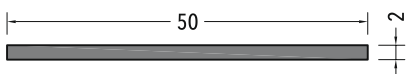

**SBP 60x2**

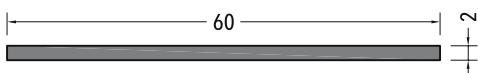

**SBP 80x2**

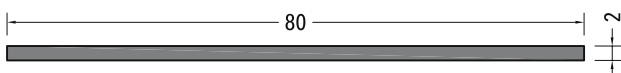

SAL 15x15x2

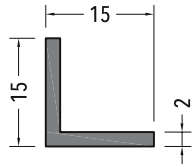

SAL 20x10x2

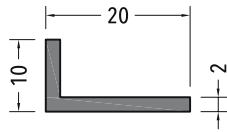

SAL 20x20x2

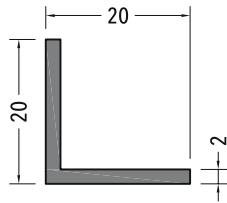

SAL 30x30x2

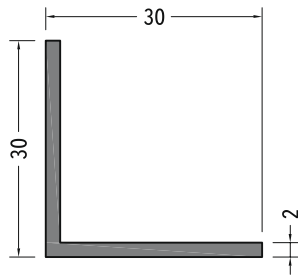

SAL 40x20x2

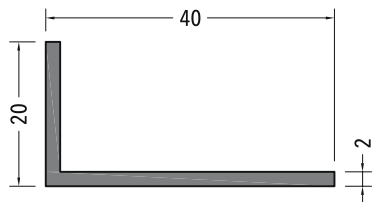

SAL 60x20x2

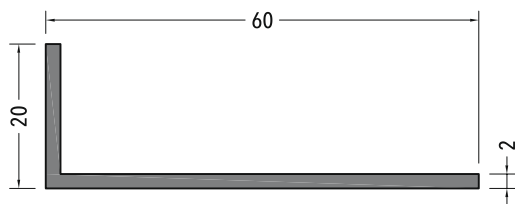

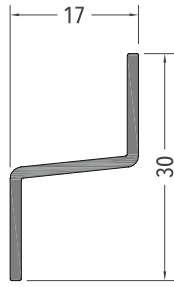
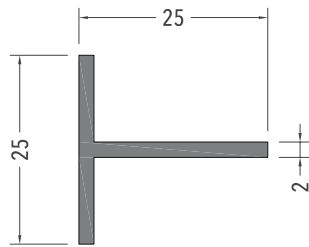
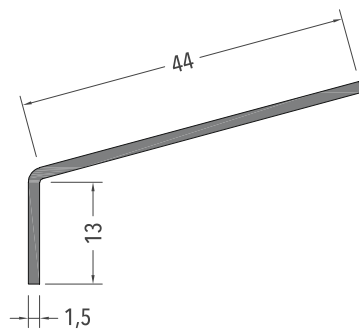
**Z 30x17****SAT 25x25x2****LBLO 44x22**

**CG 2.5**  
Clip girevole 2,5 mm

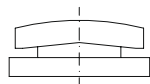

**YS 2.5**  
Clip a scatto 2,5 mm

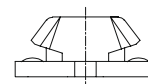

**CG 4**  
Clip girevole 4 mm

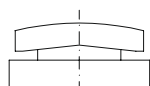

**YS 4**  
Clip a scatto 4 mm

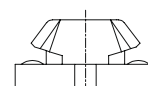

**CG 5**  
Clip girevole 5 mm

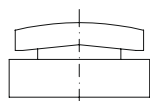

**YS 5**  
Clip a scatto 5 mm

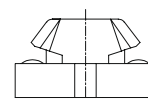

**YS 2/3**  
Clip a scatto 5 mm  
auto-posizionante

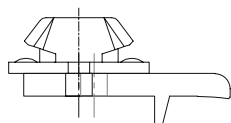

**CA 2-14**  
Clip adesiva in alluminio

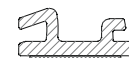

**YSG 2/3**  
Clip a scatto 5 mm  
auto-posizionante

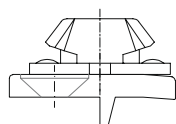

**FV 2.2**  
Basetta reggivetrol

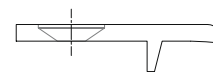

**SV 30**  
Supporto vetro in plastica

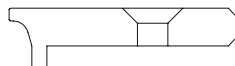

**SV 50**  
Sostegno vetro in plastica

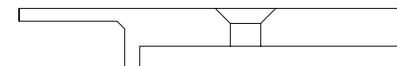

**SP 32-15**  
Supporto vetro in plastica

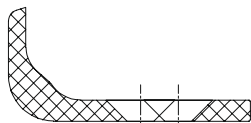

**CPT 7.15**  
Cappetta di scolo

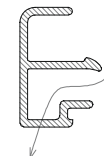

**GL 421**  
Guarnizione in EPDM  
per Sistema 21  
(telaio tipo Euronorm)

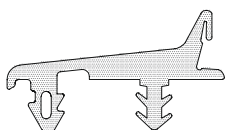

**GT 027**  
Guarnizione mono-estrusa  
in EPDM

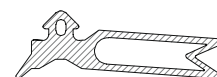

**GL 416**  
Guarnizione in EPDM  
per Sistema 16  
(telaio tipo Freumex)

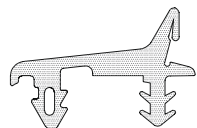

**GT 022**  
Guarnizione mono-estrusa  
in EPDM

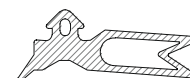

**GT 414**  
Guarnizione in EPDM  
per telaio in alluminio



**GX 1020**  
Guarnizione anta sp. 5 mm  
co-estrusa in EPDM



**GT 415**  
Guarnizione in EPDM  
per telaio in alluminio



**PAMUSS 10**  
Guarnizione in neoprene  
per PFV 16



**GA 603**  
Guarnizione anta sp. 3mm  
co-estrusa in EPDM



**GT 152**  
Guarnizione in EPDM  
per sormonto alluminio

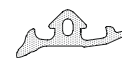

**GA 604**  
Guarnizione anta sp. 4 mm  
co-estrusa in EPDM



**GA 216**  
Guarnizione copri-clip per telaio  
in TPE (disponibile bianca o nera)



**GA 605**  
Guarnizione anta sp. 5 mm  
co-estrusa in EPDM



**GA 305**  
Guarnizione copri-clip in EPDM



**GA 212**  
Guarnizione copri-clip in TPE  
(disponibile bianca o nera)



**SP 7mm**  
Spazzolino antirumore  
per guida avvolgibile  
(fornito insieme a profilo AV 42.35)

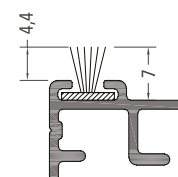

**GA 215**  
Guarnizione copri-clip in TPE  
(disponibile bianca o nera)



**SP 5mm**  
Spazzolino antirumore  
per guida avvolgibile  
(fornito insieme a profilo AV 42.35)

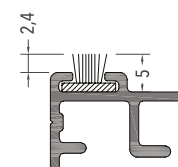

Le guarnizioni fornite nel kit Alumfast sono quelle relative al sistema alluminio (GA 604, GA 605, GT 152, GA 305, GA 212, GA 215, GT 414, GT 415, GL 416, GL 421). Tutte le guarnizioni legno, incluse le guarnizioni per la battuta interna del vetro (GA 186, GA 206, GE 504, GA 132, ecc.) saranno fornite su richiesta del cliente.

Per conoscere la gamma completa di guarnizioni legno, consultare il nostro catalogo accessori DGT SRL disponibile in download al sito [www.dgtsrl.com](http://www.dgtsrl.com).

**GC 512**  
Guarnizione tri-estrusa  
in TPE



**GV 202**  
Guarnizione per battuta interna  
in EPDM



**GC 610**  
Guarnizione tri-estrusa  
in TPE



**GE 504**  
Guarnizione per battuta interna  
in EPDM



**GA 312**  
Guarnizione in EPDM

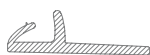

**GA 156**  
Guarnizione per battuta interna  
in TPE (fermavetro da 15 mm)



**GE 430**  
Guarnizione in EPDM

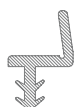

**GA 186**  
Guarnizione per battuta interna  
in TPE (fermavetro da 18 mm)



**GA 445**  
Guarnizione in EPDM



**GA 206**  
Guarnizione per battuta interna  
in EPDM (fermavetro da 20 mm)



**GD 310**  
Guarnizione tri-estrusa in TPE



**GA 919**  
Guarnizione in TPE



**GC 604**  
Guarnizione tri-estrusa in TPE



**GT 015**  
Guarnizione in TPE

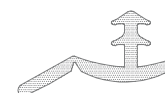

Le guarnizioni fornite nel kit Alumfast sono quelle relative al sistema alluminio (GA 604, GA 605, GT 152, GA 305, GA 212, GA 215, GT 414, GT 415, GL 416, GL 421). Tutte le guarnizioni legno, incluse le guarnizioni per la battuta interna del vetro (GA 186, GA 206, GE 504, GA 132, ecc.) saranno fornite su richiesta del cliente.

Per conoscere la gamma completa di guarnizioni legno, consultare il nostro catalogo accessori DGT SRL disponibile in download al sito [www.dgtsrl.com](http://www.dgtsrl.com).

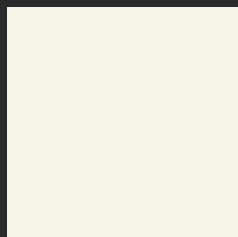

RAL 9001 \*  
Bianco crema

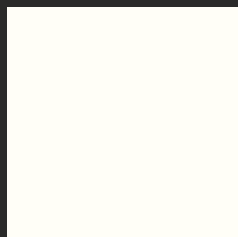

RAL 9010 \*  
Bianco puro

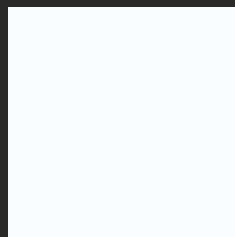

RAL 9016 OPACO  
Bianco traffico

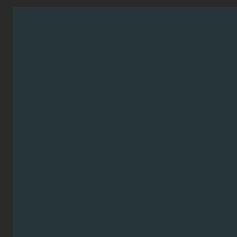

RAL 7016 \*  
Grigio antracite

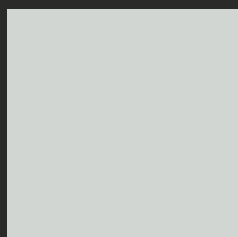

RAL 7035 \*  
Grigio luce

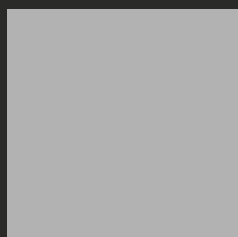

RAL 9006 \*  
Alluminio brillante

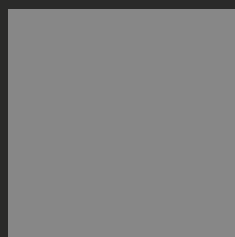

RAL 9007 OPACO  
Alluminio grigiastro

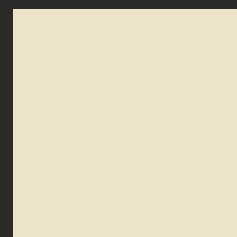

RAL 1013 \*  
Bianco perla



RAL 3005 OPACO  
Rosso vino



RAL 6005 \*  
Verde muschio

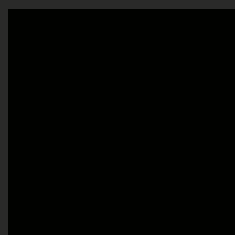

RAL 9005 \*  
Nero anodico



RAL 8011 OPACO  
Marrone noce



RAL 8017 \*  
Marrone cioccolata

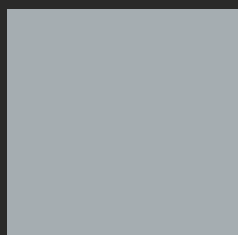

RAL 7001 OPACO  
Grigio Argento

\* Disponibile nelle versioni opaco e ruvido.



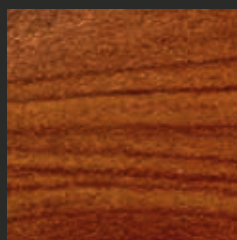

CILIEGIO 15/Z/G  
Decorato legno

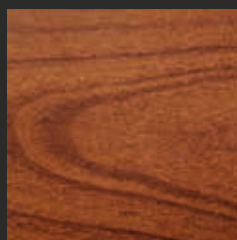

CILIEGIO S-S  
Decorato legno

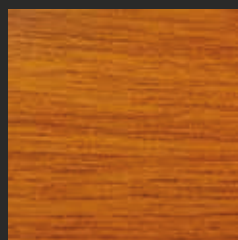

CILIEGIO H  
Decorato legno

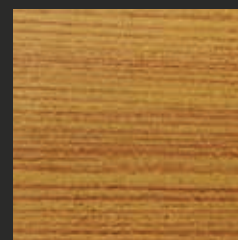

PINO U-G  
Decorato legno

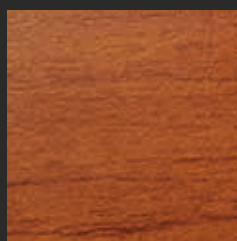

NOCE 10/L/G  
Decorato legno

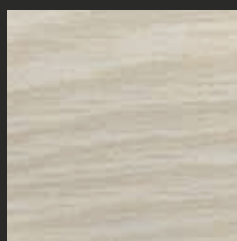

ROVERE SB.  
Decorato legno

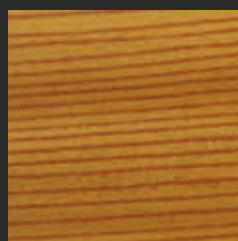

DOUGLAS H-G  
Decorato legno

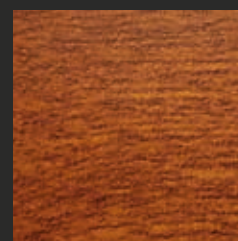

RENOLIT/R/CHIARO  
Decorato legno

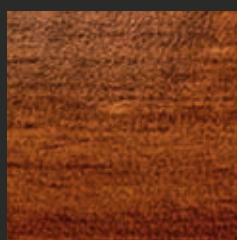

A-7-R  
Decorato legno

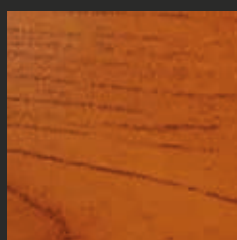

A-12-R  
Decorato legno

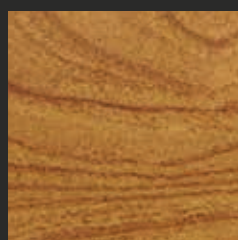

A-19-R  
Decorato legno

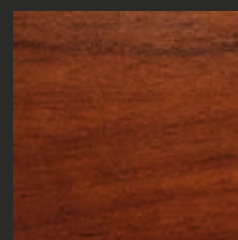

A-34-R 3D  
Decorato legno

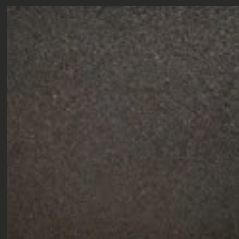

GRIGIO MIC  
Speciale

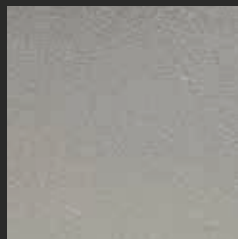

GRIGIO RAGG. MET.  
Speciale



RAL 9007 RAGG.  
MET. Speciale

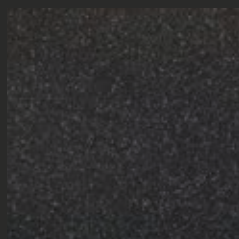

GRIGIO MIX  
Speciale

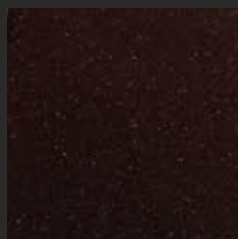

MARRONE MIX  
Speciale



CORTEN  
Speciale

Alumframe offre la possibilità di scegliere tra colorazioni RAL, speciali, decorato legno e anodizzati. I processi di verniciatura vengono realizzati con ossidazione anodica, per consentire alle finiture Alumframe di resistere alla corrosione e all'azione degradante degli agenti atmosferici. Per conoscere la gamma completa delle finiture Alumframe è possibile richiedere le cartelle colore dedicate.







I sistemi in legno-alluminio Alumframe sono progettati per portare uno stile contemporaneo e di design all'interno della tradizione degli infissi e dei serramenti in legno: linee moderne e un sistema di montaggio rapido senza rischi.

I profili legno-alluminio Alumframe danno la possibilità a costruttori e architetti di progettare nuove soluzioni e raggiungere nuovi standard performativi. Pensare oltre, guardare lontano, con in mano i giusti strumenti per innovarsi continuamente.

Alumframe è frutto di una ricerca costante che tiene conto di ogni aspetto: componenti, profili, materiali, design, prodotto finito. Ne è un esempio l'ampia gamma di accessori, quali sistemi di fissaggio, clip e guarnizioni, che permettono di agevolare la fornitura in kit e il montaggio dei profili.

Sistemi legno-alluminio contenuti nel catalogo:

Alumfast

Alumfast Easy

Alumfast Grace

Alumfast Canvas

Alumfast Orizon

Bridge

Ghost

Luce

+

Bilico

Porte ad apertura esterna

Alzanti scorrevoli

Coverfast



Alumframe è un progetto DGT srl

Via San Damiano, 3  
60020 Polverigi (AN)

[www.dgtsrl.com](http://www.dgtsrl.com)

---